

Technical data

Pump name 125X100 FSS2GC 5 H

Customer	Date 2024-06-14	Company
Contact	Item no.	Issued by
Phone	Project	Phone
E-mail	Project ID Proiect redenumit 2024-06-14 18:50:31	E-mail

Requested data

1	Pump type	End Suction Volute Pump	Fluid	Water
2	Number of pumps / Reserve	1 / 0	Liquid temperature °C	20
3	Flow m ³ /h		Kin. viscosity mm ² /s	1.005
4	Head m		Vapour pressure bar	0.0234
5	Geodetic head m		PH value	
6	Inlet pressure (pin) bar	0	Density kg/m ³	998.3
7	Available system NPSH		Solids Weight %	0
8	Ambient temperature °C	20		

Pump

9	Pump name	125X100 FSS2GC 5 H	Frequency Hz	50
10	Design	End Suction Volute Pump		
11	Manufacturer	EBARA	Impeller Diameter	Max. mm 182
12	Speed rpm	2950		Designed mm 182
13	No. of Stage	1		Min. mm 158
14	Connection Suction side	JIS 16K	Flow	Operating m ³ /h
15	Connection Discharge side	JIS 16K		Max- m ³ /h 321
16	Max Working Pressure bar	16		Min- m ³ /h 62.1
17	Shut-off head bar	4.62	Head	Operating m
18	Total weight kg	See the table of "Dimensions".		- (Qmax.) m 25.5
19	Shaft power kW			- (Qmin.) m 46.8
20			Max. Shaft Power at max. impeller kW	30.94
21	Required pump NPSH m		Efficiency %	

Materials

22	Casing	SCS13	M.S.mating ring	SIC
23	Impeller	SCS13	M.S.seal ring	Carbon
24	Shaft	SUS316L		
25	Case wear ring	SUS316		
26	Mechanical seal	SIC/Carbon		
27	Ball bearing	Grease		

Motor

28	Manufacturer	without motor	Insulation class	
29	Type	without motor 3	Phases	
30	Specific design	without motor / 50 Hz / Pole pairs 1	Frame size	
31	Rated power kW		Weight kg	
32	Number of poles	2	Electric voltage V	
33	Speed rpm		Electric current A	
34	Degree of protection			
35				

Remarks

Performance Curve

Pump Name

125X100 FSS2GC 5 H

Customer	Date	2024-06-14	Company
Contact	Item no.		Issued by
Phone	Project		Phone
E-mail	Project ID	Project redenumit 2024-06-14 18:50:31	E-mail

Requested data

1	Flow	m³/h	
2	Head	m	
3	Geodetic head	m	

Pump

Operating flow	m³/h		Frequency	Hz	50
Operating head	m		Number of poles		2
Impeller diameter designed	mm	182	Speed	rpm	2950

Test standard: ISO 9906:2012 - Grade3B

Water; 20°C; 998.3kg/m³; 1mm²/s

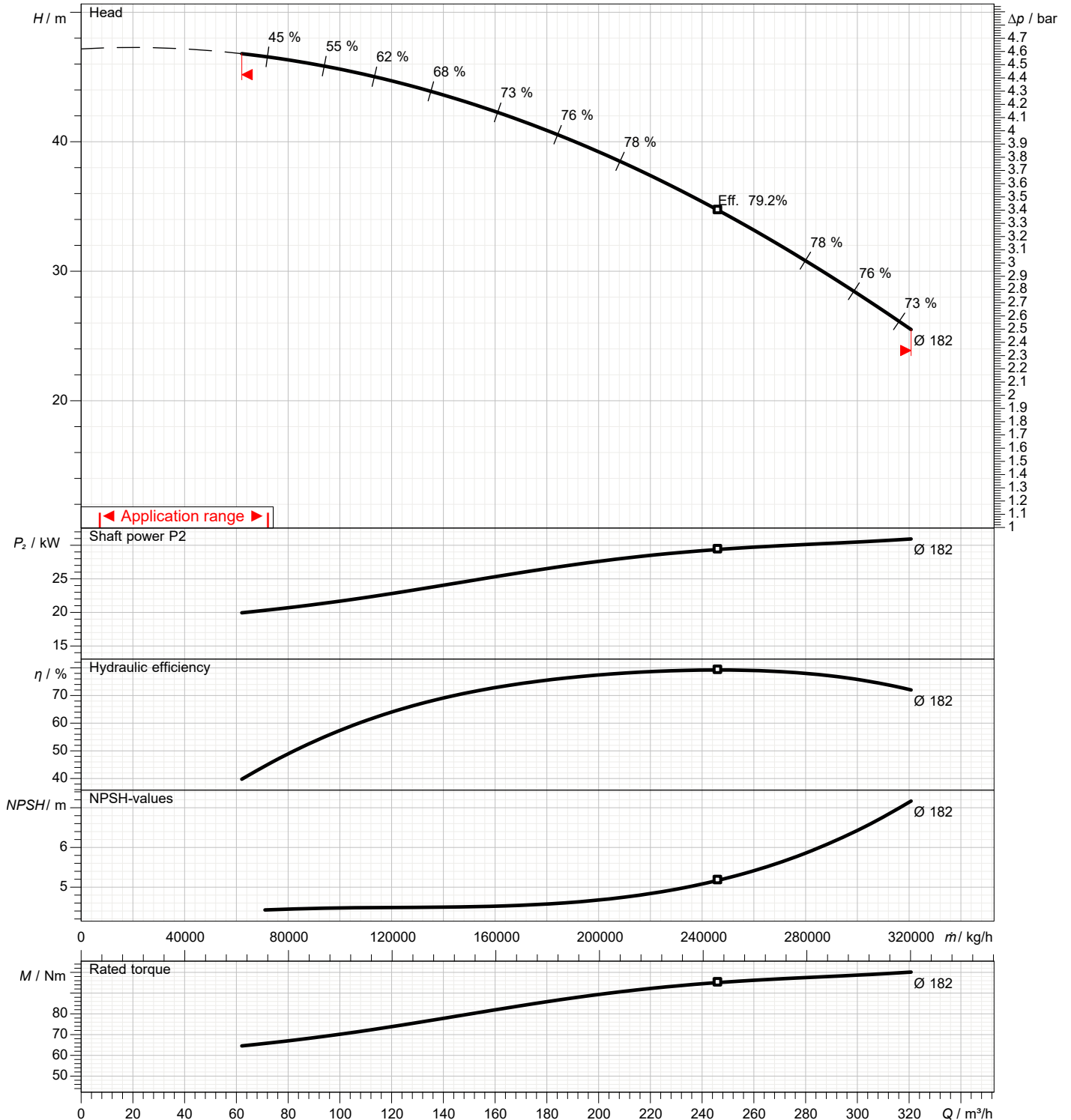

Dimensions

Pump name 125X100 FSS2GC 5 H

Customer	Date 2024-06-14	Company
Contact	Item no.	Issued by
Phone	Project	Phone
E-mail	Project ID Proiect redenumit 2024-06-14 18:50:3	E-mail

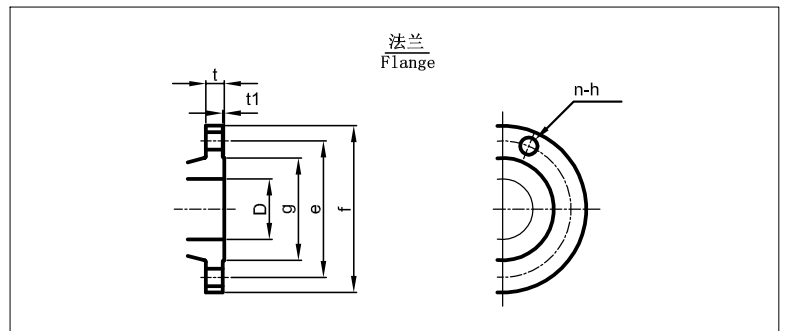
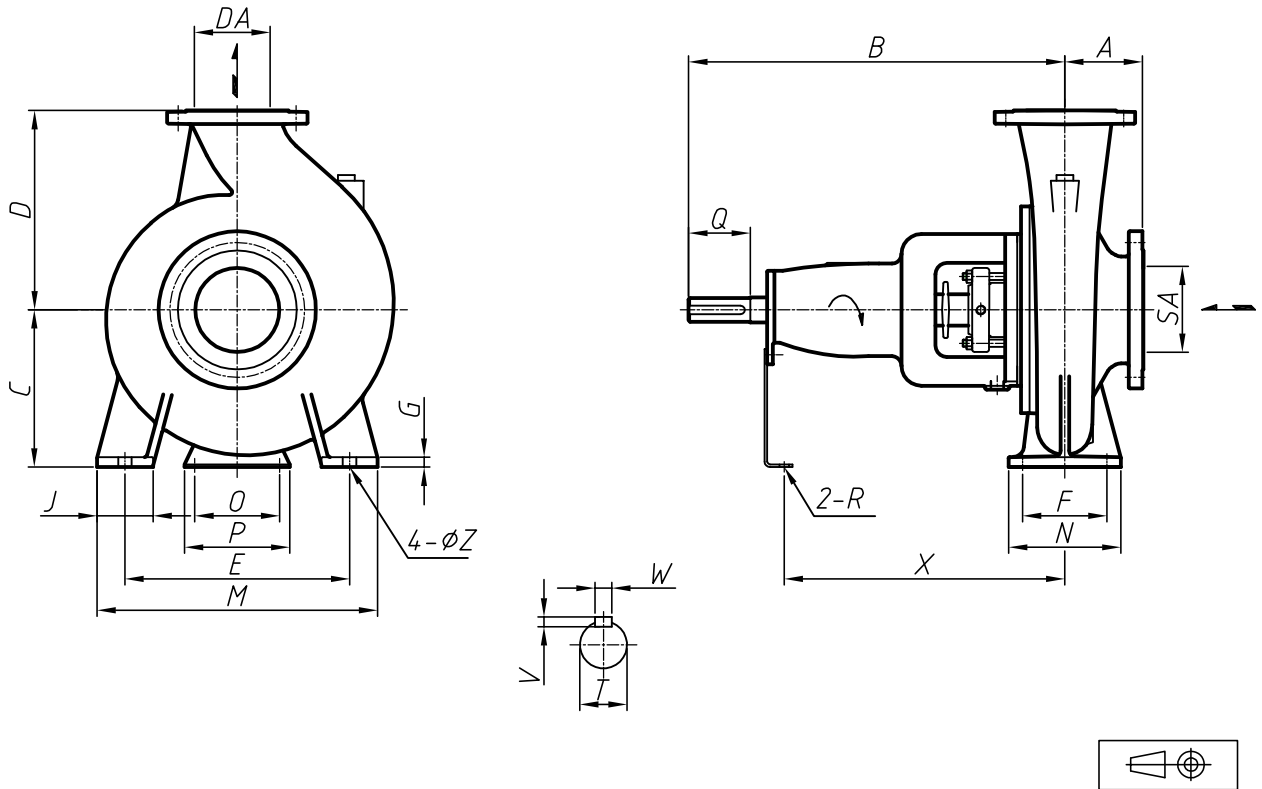

Motor manufacturer : without motor

Total weight : 60 kg

Pump dimensions				mm		Suction side		mm		Discharge side		mm	
A	125	SA	125	D	125	D	100						
B	360	T	32	e	225	e	185						
C	180	V	8	f	270	f	225						
D	250	W	10	g	195	g	160						
DA	100	X	285	h	25	h	23						
E	250	Z	15	n Num	8(Num)	n Num	8(Num)						
F	95			t	22	t	22						
G	16			t1	2	t1	2						
J	65												
M	320												
N	125												
O	110												
P	150												
Q	80												
R	17												

Construction

Pump name 125X100 FSS2GC 5 H

Customer	Date 2024-06-14	Company
Contact	Item no.	Issued by
Phone	Project	Phone
E-mail	Project ID Proiect redenumit 2024-06-14 18:50:3	E-mail



095	轴承支架 Stay	SS400	Q235A	1		903	机械挡圈 Distance piece	SUS304	06Cr19Ni10	1	
093-3	甩水环 Flinger	NBR	NBR	1		135	叶轮止动垫圈 Impeller Nut Washer	SUS304	06Cr19Ni10	1	
056	球轴承 Ball Bearing	—	—	2		120-17	紧定螺钉 Set Screw	SUS304	06Cr19Ni10	4	
053-2	轴承压盖 Bearing Cover	FC250	HT250	1		120-13	六角头螺栓 Hex.Head Bolt	SS400	Q235A	2	
051	轴承体 Bearing Housing	FC250	HT250	1		120-3	六角头螺栓/垫片 Hex.Head Bolt/Nut	SUS304	06Cr19Ni10	4	
048	叶轮螺母 Impeller Nut	SUS304	06Cr19Ni10	1		120-1	六角头螺栓/垫片 Hex.Head Bolt/Nut	SUS420J1	20Cr13	8	
039-3	联轴器用键 Key For Couplings	S50C	50#	1		120	双头螺栓 Stud Bolt	SUS304	06Cr19Ni10	4	
039-1	叶轮用键 Key For Impeller	SUS304	06Cr19Ni10	1		117-1	密封垫 Sealing Gasket	V6500	V6500	1	
031	主轴 Shaft	SUS316L	022Cr17Ni12Mo2	1		115-1	O型圈 O-rings	FPM	FPM	1	
021	叶轮 Impeller	SCS13	06Cr19Ni10	1		111	机械密封 Mechanical Seal			1 SET	
018-1	泵盖 Casing Cover	SCS13	06Cr19Ni10	1		107-2	密封环 Case Wear Ring	SUS316	06Cr17Ni12Mo2	1	
016	机械密封 Mechanical Sealing Gland	SUS304	06Cr19Ni10	1		107-1	密封环 Case Wear Ring	SUS316	06Cr17Ni12Mo2	1	
001	泵壳 Casing	SCS13	06Cr19Ni10	1							
零件号 No.	零件名 Name of Part	材料 Material		数量 No.	备注 Remark	零件号 No.	零件名 Name of Part	材料 Material		数量 No.	备注 Remark
		JIS	GB					JIS	GB		

注意: 上表只显示标准配置的材料, 如有其他材料要求, 请参照技术数据表。

Note: The table above shows material of standard specification.

Please refer to the Data Sheet if designated material is required.