

Technical data

Pump name 250X200 FSS4KC 5 75 H

Customer	Date 2024-06-14	Company
Contact	Item no.	Issued by
Phone	Project	Phone
E-mail	Project ID Proiect redenumit 2024-06-14 18:50:31	E-mail

Requested data

1	Pump type	End Suction Volute Pump	Fluid	Water
2	Number of pumps / Reserve	1 / 0	Liquid temperature °C	20
3	Flow m ³ /h		Kin. viscosity mm ² /s	1.005
4	Head m		Vapour pressure bar	0.0234
5	Geodetic head m		PH value	
6	Inlet pressure (pin) bar	0	Density kg/m ³	998.3
7	Available system NPSH		Solids Weight %	0
8	Ambient temperature °C	20		

Pump

9	Pump name	250X200 FSS4KC 5 75 H	Frequency Hz	50
10	Design	End Suction Volute Pump		
11	Manufacturer	EBARA	Impeller Diameter	Max. mm 335
12	Speed rpm	1450		Designed mm 335
13	No. of Stage	1		Min. mm 273
14	Connection Suction side	JIS 16K	Flow	Operating m ³ /h
15	Connection Discharge side	JIS 16K		Max- m ³ /h 894
16	Max Working Pressure bar	16		Min- m ³ /h 180
17	Shut-off head bar	3.56	Head	Operating m
18	Total weight kg	See the table of "Dimensions".		- (Qmax.) m 23.3
19	Shaft power kW			- (Qmin.) m 35.3
20			Max. Shaft Power at max. impeller kW	72.40
21	Required pump NPSH m		Efficiency %	

Materials

22	Casing	SCS13	M.S.mating ring	SIC
23	Impeller	SCS13	M.S.seal ring	Carbon
24	Shaft	SUS316L		
25	Case wear ring	SUS316		
26	Mechanical seal	SIC/Carbon		
27	Ball bearing	Grease		

Motor

28	Manufacturer	SIEMENS	Insulation class	F
29	Type	280S_B3_75_3_380	Phases	3~
30	Specific design	TEFC / 50 Hz / Pole pairs 2	Frame size	280 S
31	Rated power kW	75	Weight kg	550
32	Number of poles	4	Electric voltage V	380
33	Speed rpm	1485	Electric current A	139
34	Degree of protection	IP55		
35				

Remarks

Performance Curve

Pump Name

250X200 FSS4KC 5 75 H

Customer	Date	2024-06-14	Company
Contact	Item no.		Issued by
Phone	Project		Phone
E-mail	Project ID	Proiect redenumit 2024-06-14 18:50:31	E-mail

Requested data

1	Flow	m³/h	
2	Head	m	
3	Geodetic head	m	

Pump

Operating flow	m³/h		Frequency	Hz	50
Operating head	m		Number of poles		4
Impeller diameter designed	mm	335	Speed	rpm	1450

Test standard: ISO 9906:2012 - Grade3B

Water; 20°C; 998.3kg/m³; 1mm²/s

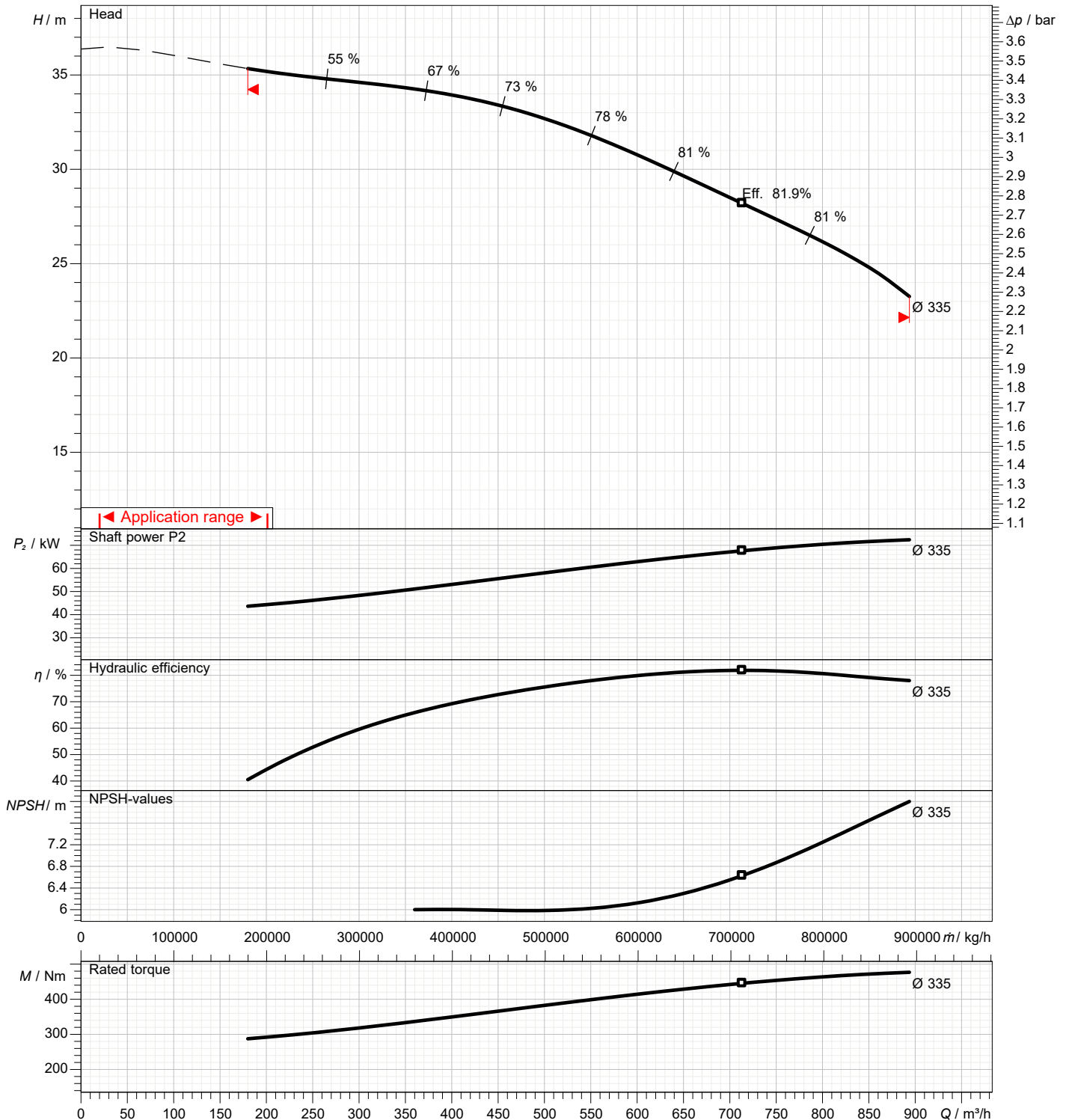

Dimensions

Pump name 250X200 FSS4KC 5 75 H

Customer	Date 2024-06-14	Company
Contact	Item no.	Issued by
Phone	Project	Phone
E-mail	Project ID Project redenumit 2024-06-14 18:50:3	E-mail

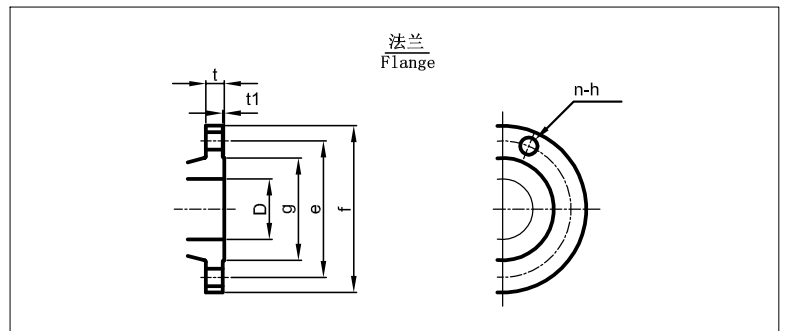
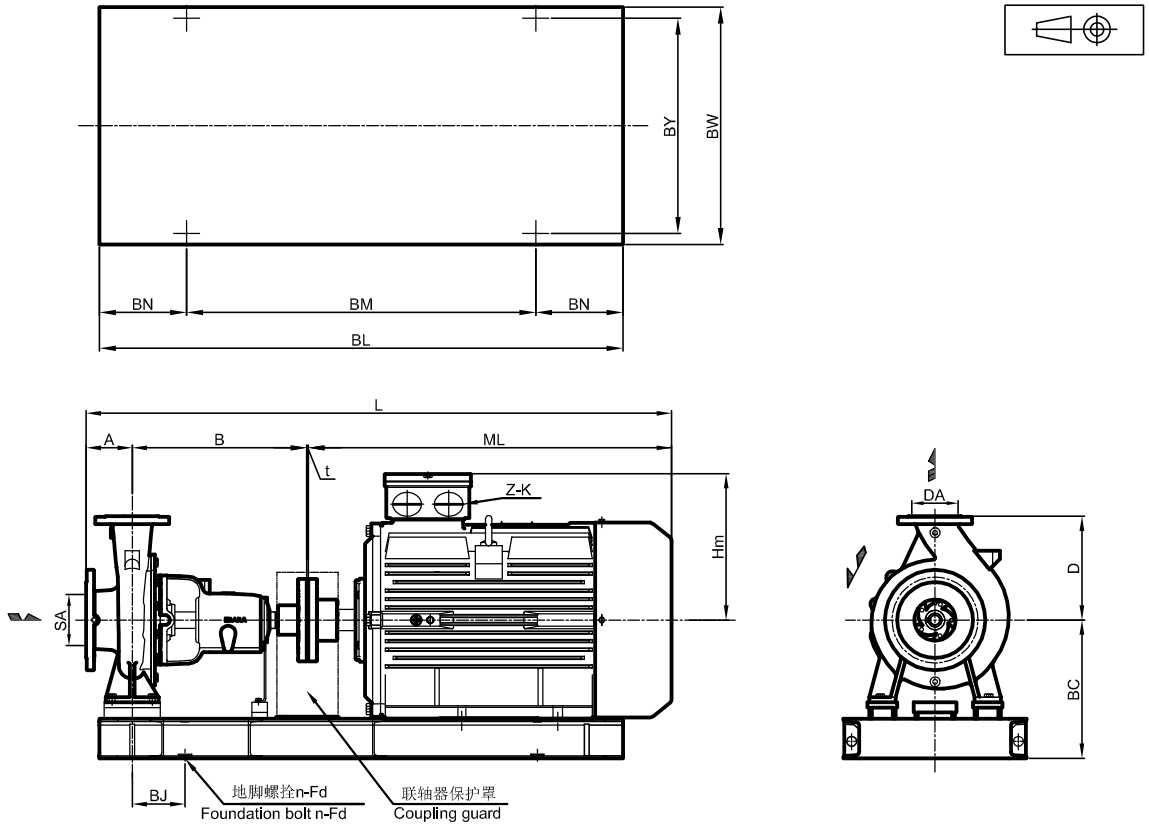

Motor manufacturer : SIEMENS

Total weight : 1195 kg

Pump dimensions				mm		Suction side		mm		Discharge side		mm	
A	200	n	4(Num)	D	250	D	200						
B	690	SA	250	e	380	e	305						
BC	540	t	4	f	430	f	350						
BJ	100	Z-K	2-M63X1.5	g	345	g	275						
BL	1635			h	27	h	25						
BM	1095			n Num	12(Num)	n Num	12(Num)						
BN	270			t	28	t	26						
BW	580			t1	2	t1	2						
BY	535												
D	400												
DA	200												
Fd	24												
Hm	413												
L	1874												
ML	980												

Construction

Pump name 250X200 FSS4KC 5 75 H

Customer	Date 2024-06-14	Company
Contact	Item no.	Issued by
Phone	Project	Phone
E-mail	Project ID Proiect redenumit 2024-06-14 18:50:3	E-mail

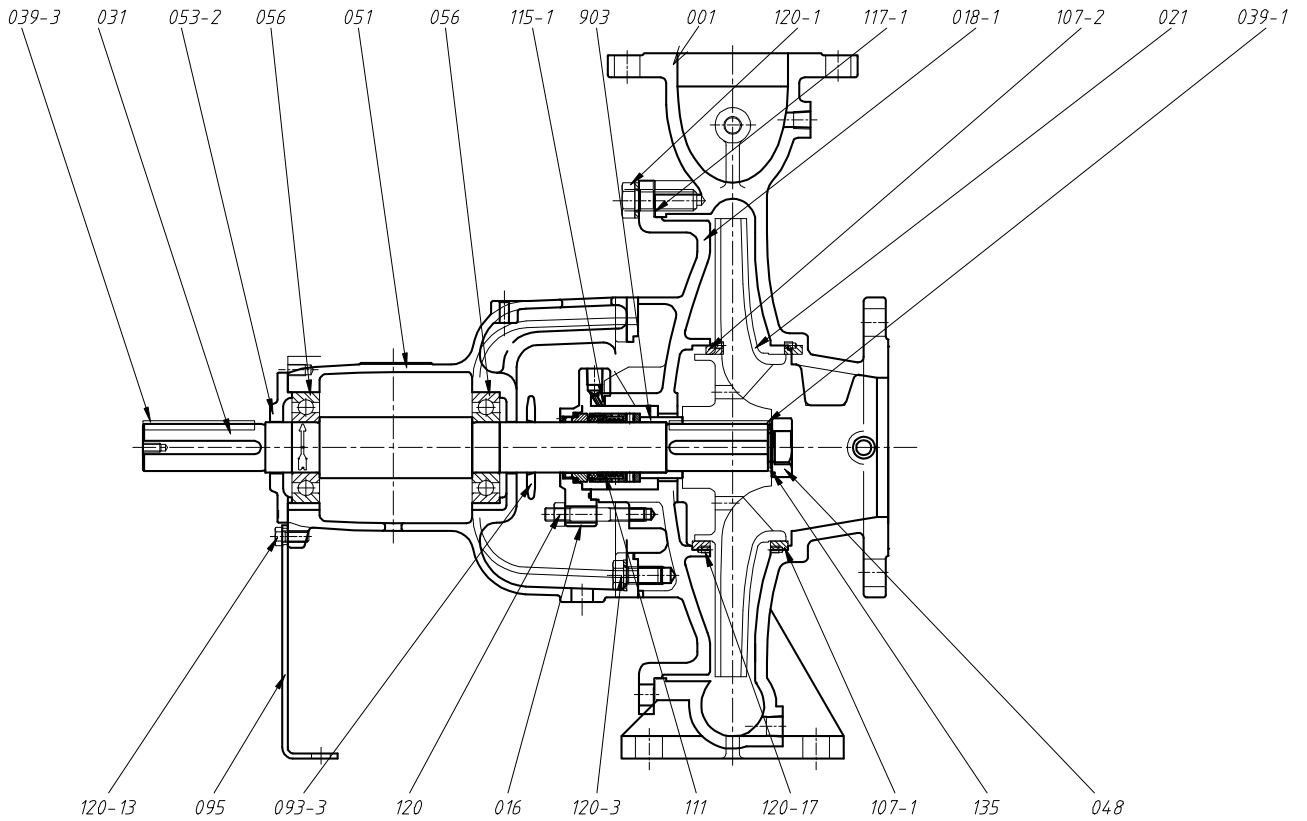

095	轴承支架 Stay	SS400	Q235A	1		903	机械挡圈 Distance piece	SUS304	06Cr19Ni10	1	
093-3	甩水环 Flinger	NBR	NBR	1		135	叶轮止动垫圈 Impeller Nut Washer	SUS304	06Cr19Ni10	1	
056	球轴承 Ball Bearing	—	—	2		120-17	紧定螺钉 Set Screw	SUS304	06Cr19Ni10	4	
053-2	轴承压盖 Bearing Cover	FC250	HT250	1		120-13	六角头螺栓 Hex.Head Bolt	SS400	Q235A	2	
051	轴承体 Bearing Housing	FC250	HT250	1		120-3	六角头螺栓/垫片 Hex.Head Bolt/Nut	SUS304	06Cr19Ni10	4	
048	叶轮螺母 Impeller Nut	SUS304	06Cr19Ni10	1		120-1	六角头螺栓/垫片 Hex.Head Bolt/Nut	SUS420J1	20Cr13	8	
039-3	联轴器用键 Key For Couplings	S50C	50#	1		120	双头螺栓 Stud Bolt	SUS304	06Cr19Ni10	4	
039-1	叶轮用键 Key For Impeller	SUS304	06Cr19Ni10	1		117-1	密封垫 Sealing Gasket	V6500	V6500	1	
031	主轴 Shaft	SUS316L	022Cr17Ni12Mo2	1		115-1	O型圈 O-rings	FPM	FPM	1	
021	叶轮 Impeller	SCS13	06Cr19Ni10	1		111	机械密封 Mechanical Seal			1 SET	
018-1	泵盖 Casing Cover	SCS13	06Cr19Ni10	1		107-2	密封环 Case Wear Ring	SUS316	06Cr17Ni12Mo2	1	
016	机械密封 Mechanical Sealing Gland	SUS304	06Cr19Ni10	1		107-1	密封环 Case Wear Ring	SUS316	06Cr17Ni12Mo2	1	
001	泵壳 Casing	SCS13	06Cr19Ni10	1							
零件号 No.	零件名 Name of Part	JIS	GB	数量 No.	备注 Remark	零件号 No.	零件名 Name of Part	JIS	GB	数量 No.	备注 Remark
		材料 Material						材料 Material			

注意: 上表只显示标准配置的材料, 如有其他材料要求, 请参照技术数据表。

Note: The table above shows material of standard specification.

Please refer to the Data Sheet if designated material is required.