

Technical Data

Booster set name

2GPE EVMS10 15N5/5,5 ESPT (UK)

Customer	Date	09.06.2024	Company
Contact	Item no.		Issued by
Phone	Project		Phone
E-mail	Project ID		E-mail

Requested data

1	Pump type	Booster Set	Fluid	Water
2	Number of pumps	2	Liquid temperature	°C 20
3	Flow	m ³ /h	Kin. viscosity	cSt 1.005
4	Head	m	Vapour pressure	kPa 2.34
5	Geodetic head	m	PH value	
6	Inlet pressure	kPa 0	Density	kg/m ³ 998.3
7	Available system NPSH	Ask our technical department.	Solids	Weight % 0
8	Ambient temperature	°C 20	Installation height	m 100

Booster Set

9	Booster set name	2GPE EVMS10 15N5/5,5 ESPT (UK)	Frequency	Hz 50
10	Design	Booster Set		
11	Manufacturer	EBARA	Impeller Dia.	Max. mm 96
12	Speed	rpm 2930		Designed mm 96
13	No. of Stage	15		Min. mm 96
14	Connection	Suction side UNI ISO 228 PN16	Flow	Operating m ³ /h
15	Connection	Discharge side UNI ISO 228 PN16		Max- m ³ /h 15
16	Max Working Pressure	kPa 1600		Min- m ³ /h 4.5
17	Shut-off head	kPa 1633.36	Head	Operating m
18	Total weight	kg See the table of "Dimensions".		- (Qmax.) m 77.3
19	Shaft power	kW		- (Qmin.) m 162.5
20			Max. Shaft Power at max. impeller	kW 5.47
21	Required NPSH	m	Efficiency	%

Materials

22	Frame	Galvanized steel	Shaft	AISI 304
23	Manifold	AISI 304	O-ring	EPDM
24	Check valve	Brass / NBR		
25	Ball / Butterfly valve	Brass / PTFE		
26	Impeller	AISI 304		
27	Casing	AISI 304		

Motor

28	Manufacturer	ETM	Insulation class	F
29	Type	TEFC_EVMS10 15/5.5_400_Three Phase	Phases	3~
30	Specific design	IE3 / 50 Hz / Pole pairs 1	Frame size	132
31	Rated power	kW 5.5	Weight; motor	kg 39
32	Number of poles	2	Electric voltage	V 400
33	Speed	rpm 2925	Electric current	A 10.4
34	Degree of protection	IP 55		
35				

Remarks

Item intended for the UK market only.

Performance curve

Booster set name

2GPE EVMS10 15N5/5,5 ESPT (UK)

Customer	Date	09.06.2024	Company
Contact	Item no.		Issued by
Phone	Project		Phone
E-mail	Project ID		E-mail

Requested data

1	Flow	m ³ /h	
2	Head	m	
3	Geodetic head	m	

Booster set

Operating flow	m ³ /h		Frequency	Hz	50
Operating head	m		Number of poles		2
ImpellerDiameter Designed	mm	96	Speed	rpm	2930

Test standard: ISO 9906:2012 - Grade3B

Water; 20°C; 998.3kg/m³; 1cSt

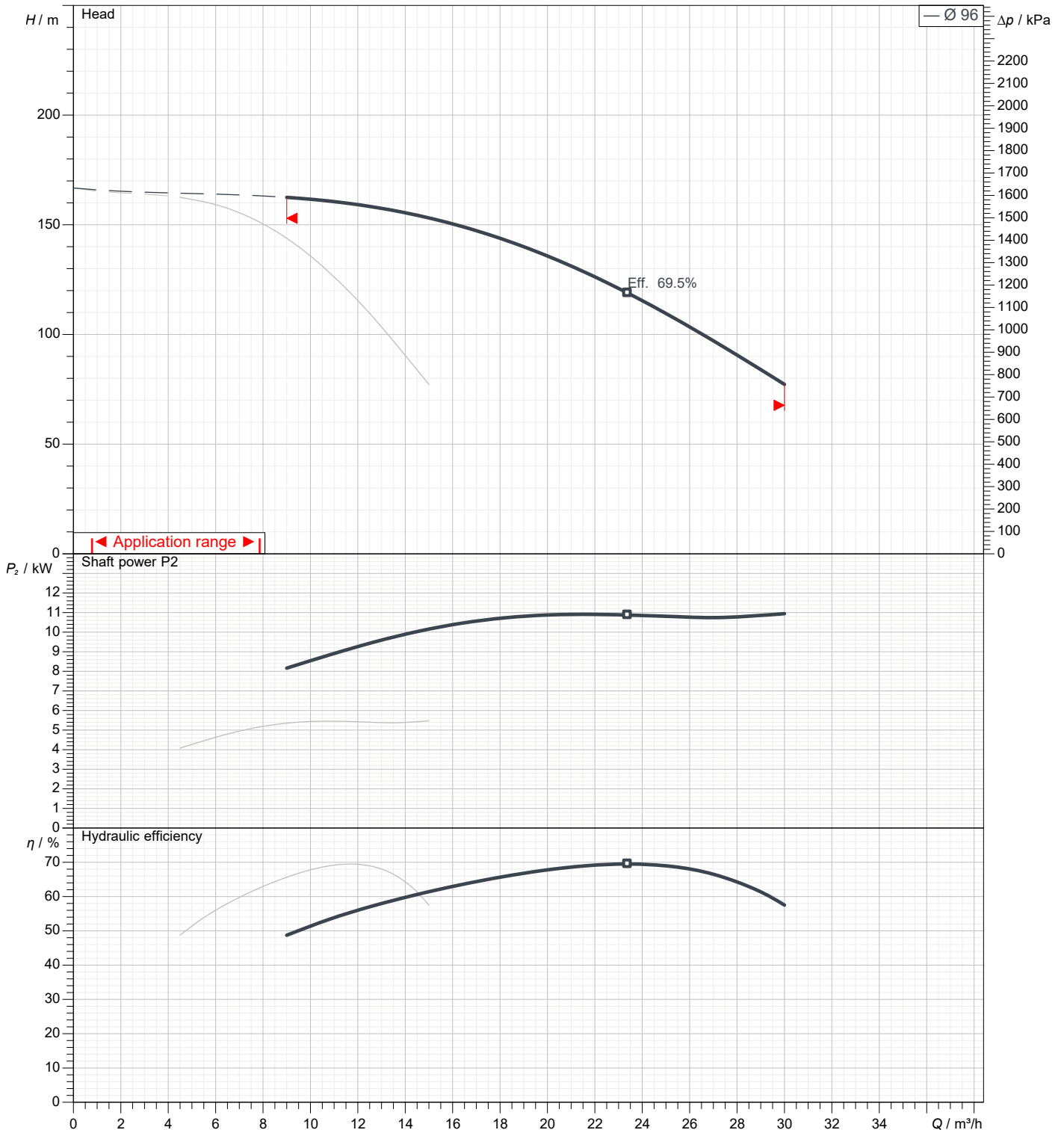

Dimensions

Booster set name

2GPE EVMS10 15N5/5,5 ESPT (UK)

Customer	Date 09.06.2024	Company
Contact	Item no.	Issued by
Phone	Project	Phone
E-mail	Project ID	E-mail

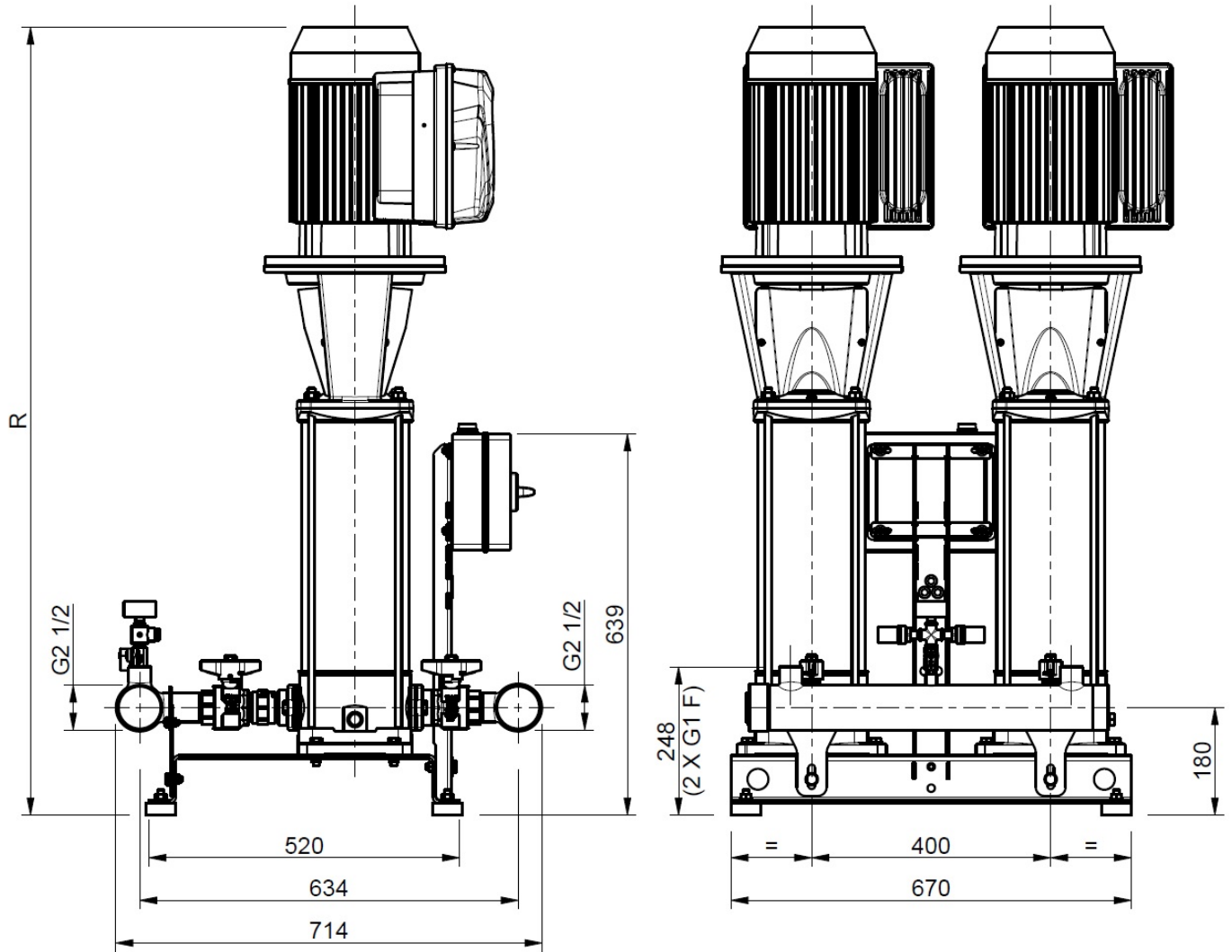

Dimensions in		mm						
1	R	1350						
2	Weight kg	200						
3								
4								
5								
6								
7								
8								
9								
10								
11								
12								
13								
14								
15								

(1/2) Construction

Booster set name

2GPE EVMS10 15N5/5,5 ESPT (UK)

Customer	Date 09.06.2024	Company
Contact	Item no.	Issued by
Phone	Project	Phone
E-mail	Project ID	E-mail

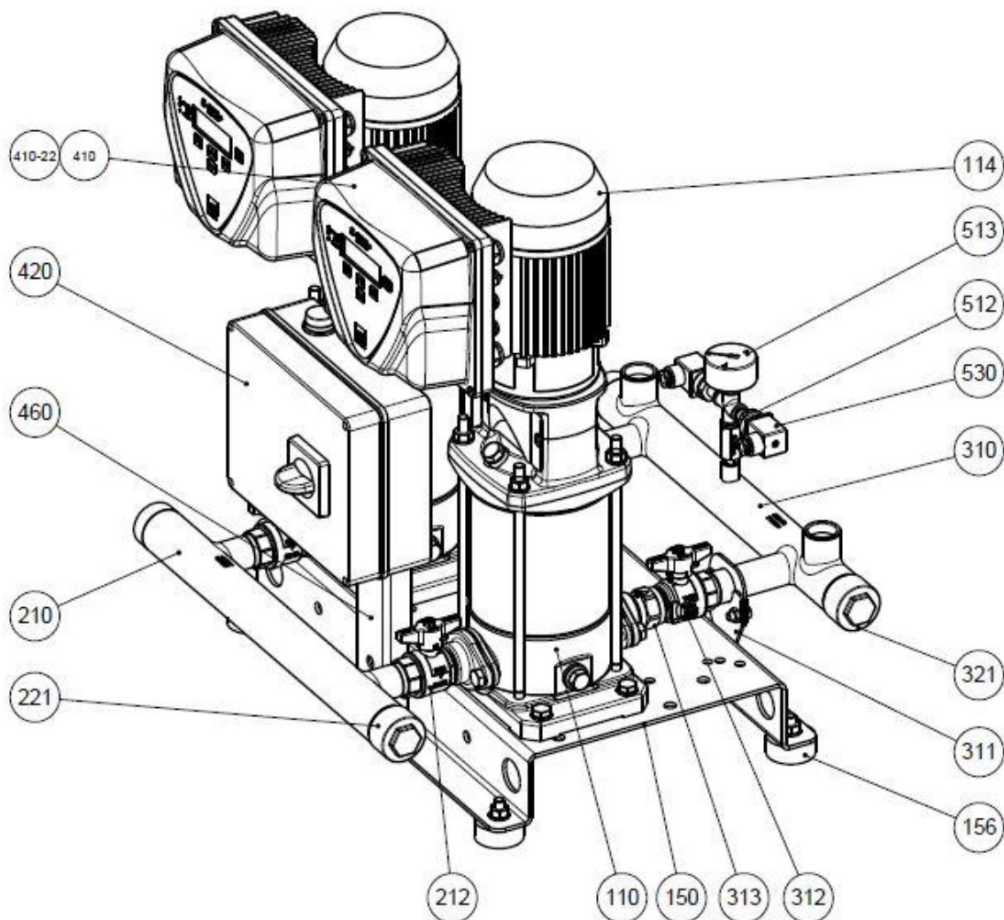

N°	PART NAME	MATERIAL	Quantity
110	Principal pump	-	2
114	Electric motor	-	2
150	Baseplate	Galvanized steel	1
156	Baseplate foot	SBR	4
210	Suction manifold	AISI 304	1
212	Ball valve	Brass / P.T.F.E.	2
221	Threaded female cap	AISI 304	1
310	Discharge manifold	AISI 304	1
311	Manifold bracket	Galvanized steel	2
312	Ball valve	Brass / P.T.F.E.	2
313	Check valve	Brass / NBR	2
321	Threaded female cap	AISI 304	1
410	E-SPD+	-	2
410-22	E-SPD+ adaptor	-	2
420	Protection panel	-	1
460	Protection panel frame	Galvanized steel	1
512	Ball valve	Brass / P.T.F.E.	1
513	Pressure gauge	Copper alloy / plastic	1
530	Pressure transmitter	-	2

(2/2) Construction

Booster set name
2GPE EVMS10 15N5/5,5 ESPT (UK)

Customer	Date 09.06.2024	Company
Contact	Item no.	Issued by
Phone	Project	Phone
E-mail	Project ID	E-mail

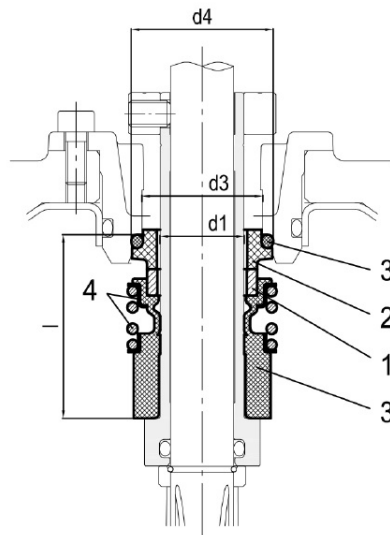

● : Standard

Pump model	Max operating pressure	Max operating temperature	Shaft seal type		Shaft seal material							Type key	
			Unbalanced	Balanced	1 Rotating Part	Code	2 Stationary Part	Code	3 Elastomers	Code	4 Compression spring		5 Collar
up to 16 bar	- 30°C to + 120°C	●			SiC	(Q1)	Carbon	(B)	EPDM	(E)	AlSi 316	(G)	Q1BEG

Max operating pressure	d1	d2	d3	d4	l
	[mm]	[mm]	[mm]	[mm]	[mm]
16 bar	20	-	29	35	37.5