

# Technical Data

Booster set name

2GP 2CDX 70/20M

Customer	Date 09.06.2024	Company
Contact	Item no.	Issued by
Phone	Project	Phone
E-mail	Project ID	E-mail

## Requested data

1	Pump type	Booster Set	Fluid	Water
2	Number of pumps	2	Liquid temperature °C	20
3	Flow m³/h		Kin. viscosity cSt	1.005
4	Head m		Vapour pressure kPa	2.34
5	Geodetic head m		PH value	
6	Inlet pressure kPa	0	Density kg/m³	998.3
7	Available system NPSH	Ask our technical department.	Solids Weight %	0
8	Ambient temperature °C	20	Installation height m	100

## Booster Set

9	Booster set name	2GP 2CDX 70/20M	Frequency Hz	50
10	Design	Booster Set		
11	Manufacturer	EBARA	Impeller Dia.	Max. mm 153
12	Speed rpm	2800		Designed mm 153
13	No. of Stage	2		Min. mm 153
14	Connection Suction side	G 2 PN10	Flow	Operating m³/h
15	Connection Discharge side	G 1 1/2 PN10		Max- m³/h 4.8
16	Max Working Pressure kPa	800		Min- m³/h 1.2
17	Shut-off head kPa	626.77	Head	Operating m
18	Total weight kg	See the table of "Dimensions".		- (Qmax.) m 44.0
19	Shaft power kW			- (Qmin.) m 60.0
20			Max. Shaft Power at max. impeller kW	1.69
21	Required NPSH m		Efficiency %	

## Materials

22	Frame	Galvanized steel	Casing cover	AISI 304
23	Manifold	AISI 304	Shaft	AISI 304
24	Check valve	Brass / NBR	Shaft seal	Ceramic/Carbon/NBR
25	Ball valve	Brass / PTFE	O-ring	NBR
26	Impeller	AISI 304	Diffuser	AISI 304
27	Casing	AISI 304		

## Motor

28	Manufacturer	EPE Standard	Insulation class	F
29	Type	TEFC_2CDXM 70/20_230_Single Phase	Phases	1~
30	Specific design	- / 50 Hz / Pole pairs 1	Frame size	
31	Rated power kW	1.5	Weight; motor kg	
32	Number of poles	2	Electric voltage V	230
33	Speed rpm	2800	Electric current A	10
34	Degree of protection	IP 55		
35				

## Remarks

# Performance curve

Booster set name  
2GP 2CDX 70/20M

Customer	Date	09.06.2024	Company
Contact	Item no.		Issued by
Phone	Project		Phone
E-mail	Project ID		E-mail

## Requested data

1	Flow	m³/h	
2	Head	m	
3	Geodetic head	m	

## Booster set

Operating flow	m³/h		Frequency	Hz	50
Operating head	m		Number of poles		2
ImpellerDiameter Designed	mm	153	Speed	rpm	2800

Test standard: ISO 9906:2012 - Grade3B

Water; 20°C; 998.3kg/m³; 1cSt

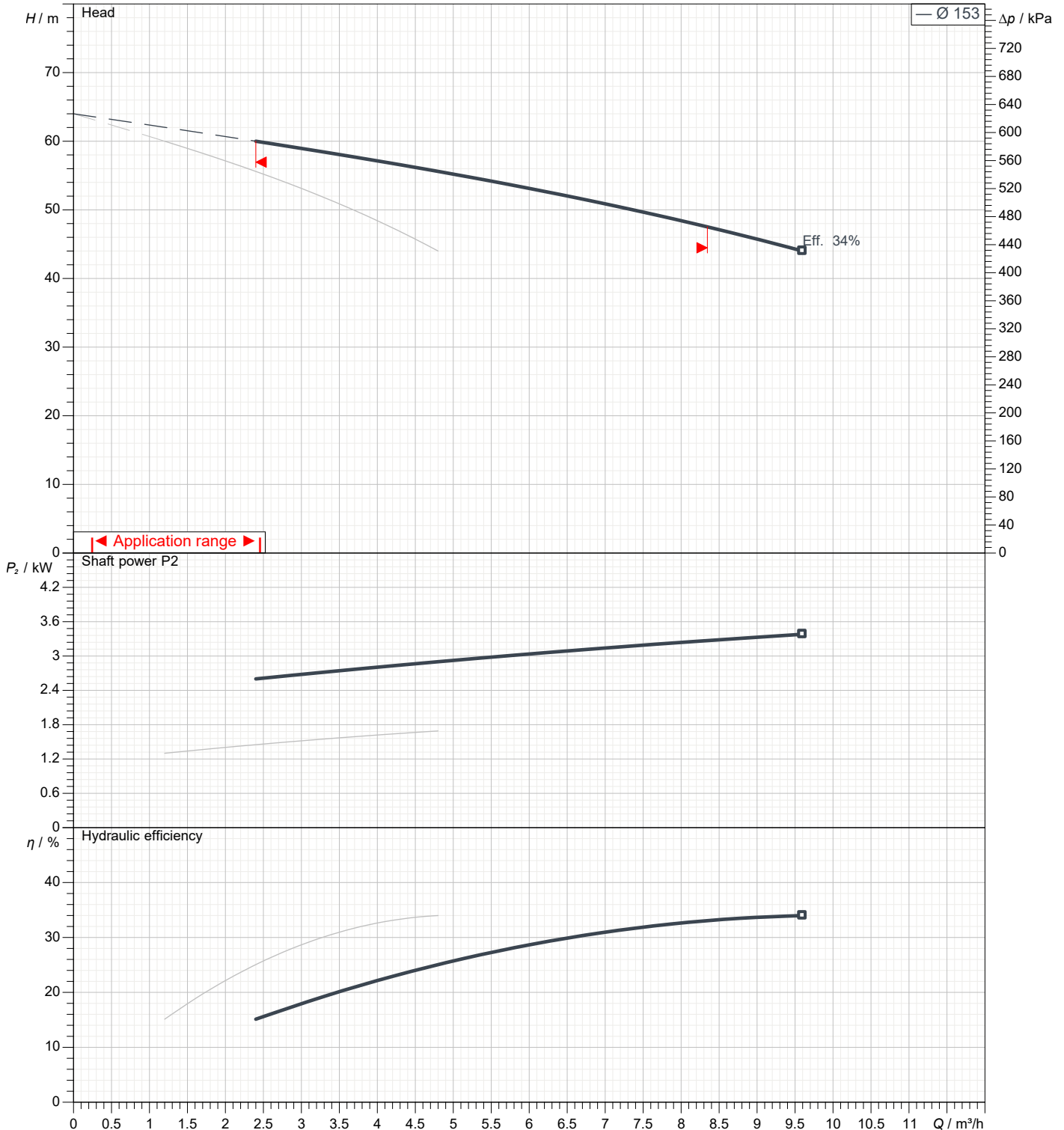

# Dimensions

Booster set name  
2GP 2CDX 70/20M

Customer	Date 09.06.2024	Company
Contact	Item no.	Issued by
Phone	Project	Phone
E-mail	Project ID	E-mail

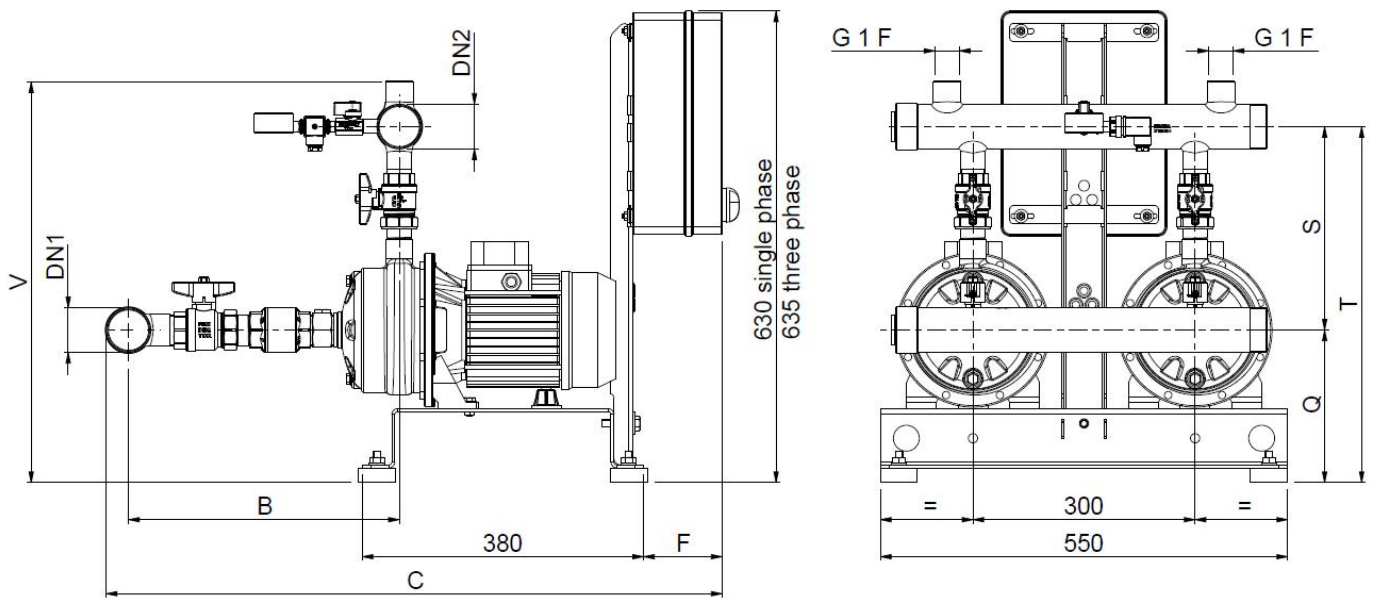

Dimensions in		mm						
1	B	365						
2	C	800						
3	DN1	G 2						
4	DN2	G 1 1/2						
5	F	75						
6	Q	220						
7	S	280						
8	T	500						
9	V	550						
10	Weight kg	69						
11								
12								
13								
14								
15								

# (1/2) Construction

Booster set name  
2GP 2CDX 70/20M

Customer	Date 09.06.2024	Company
Contact	Item no.	Issued by
Phone	Project	Phone
E-mail	Project ID	E-mail

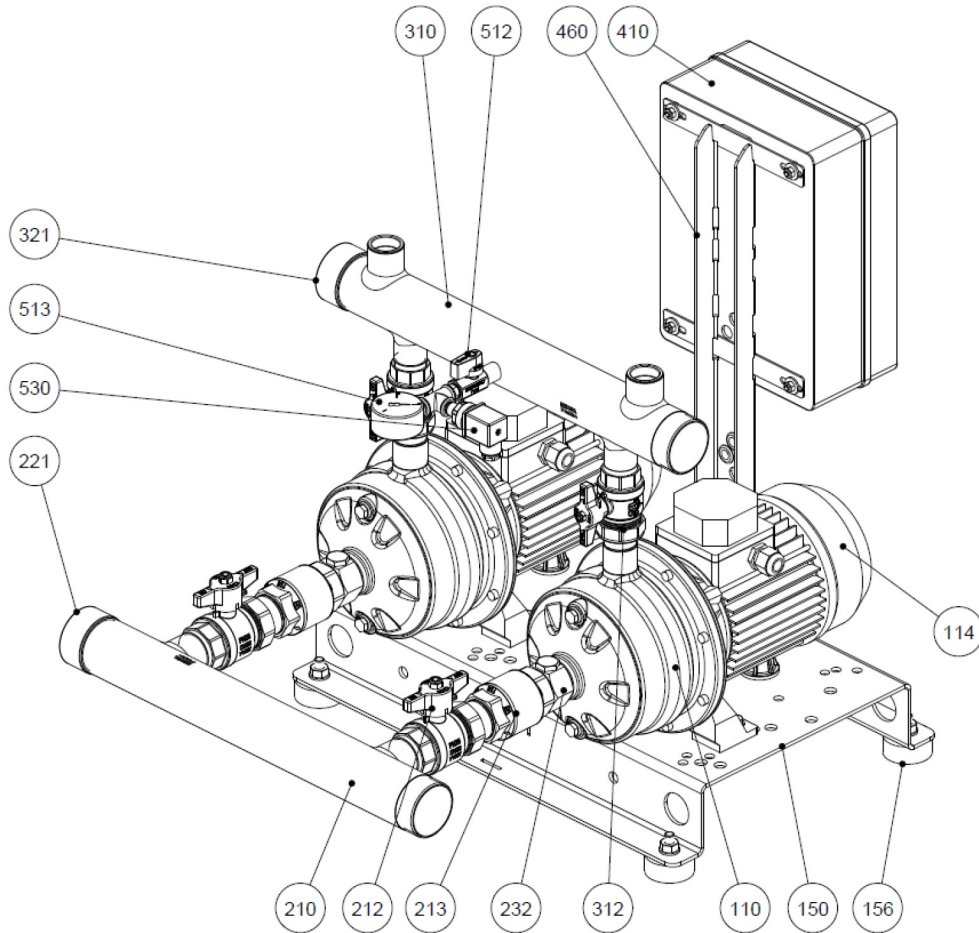

N°	PART NAME	MATERIAL	Quantity
110	Principal pump	-	2
114	Electric motor	-	2
150	Baseplate	Galvanized steel	1
156	Baseplate foot	SBR	4
210	Suction manifold	AISI 304	1
212	Union ball valve	Brass / P.T.F.E.	2
213	Check valve	Brass / NBR	2
221	Threaded female cap	AISI 304	1
232	Nipple for air feeders	Yellow brass	2
310	Discharge manifold	AISI 304	1
312	Union ball valve	Brass / P.T.F.E.	2
321	Threaded female cap	AISI 304	1
410	Control panel	-	1
460	Control panel frame	Galvanized steel	1
512	Ball valve	Brass / P.T.F.E.	1
513	Pressure gauge	Copper alloy / plastic	1
530	Pressure transmitter	-	1

# (2/2) Construction

Booster set name  
2GP 2CDX 70/20M

Customer	Date 09.06.2024	Company
Contact	Item no.	Issued by
Phone	Project	Phone
E-mail	Project ID	E-mail

## MECHANICAL SEAL

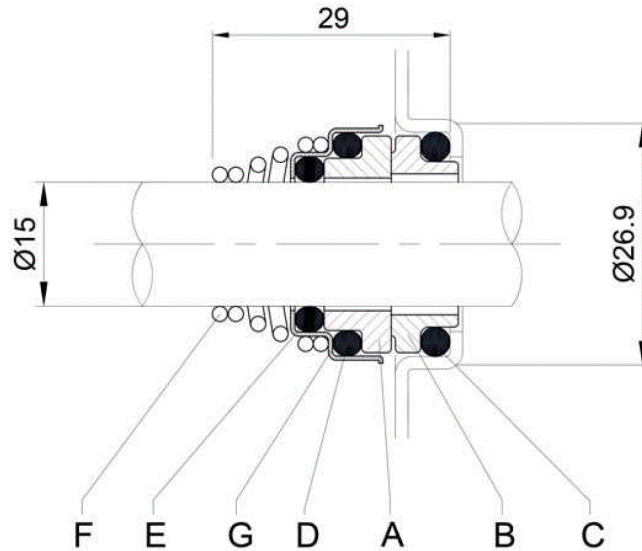

STANDARD  
+  
"L" version

REF	PART NAME	MATERIAL
A	Rotary seal ring	Ceramic
B	Stationary seal ring	Carbon graphite
C	O-Ring	NBR
D	O-Ring	NBR
E	O-Ring	NBR
F	Self-driving spring	AISI 316
G	Frame	AISI 304

## BEARINGS

Pump type		Ball Bearing	
Single Phase	Three Phase	Pump side	Fan side
2CDXM 70/10	2CDX 70/10	6203-ZZ C3	6202-ZZ C3
2CDXM 70/12	2CDX 70/12	6203-ZZ C3	6202-ZZ C3
2CDXM 70/15	2CDX 70/15	6204-ZZ C3	6203-ZZ C3
2CDXM 70/20	2CDX 70/20	6204-ZZ C3	6203-ZZ C3
2CDXM 120/15	2CDX 120/15	6204-ZZ C3	6203-ZZ C3
2CDXM 120/20	2CDX 120/20	6204-ZZ C3	6203-ZZ C3
-	2CDX 120/30	6305-ZZ C3	6205-ZZ C3
-	2CDX 120/40	6305-ZZ C3	6205-ZZ C3
-	2CDX 200/30	6205-ZZ C3	6205-ZZ C3
-	2CDX 200/40	6305-ZZ C3	6205-ZZ C3
-	2CDX 200/50	6206-ZZ C3	6205-ZZ C3