

Technical Data

Booster set name

2GP MATRIX 5-4T/0,9

Customer	Date	09.06.2024	Company
Contact	Item no.		Issued by
Phone	Project		Phone
E-mail	Project ID		E-mail

Requested data

1	Pump type	Booster Set	Fluid	Water
2	Number of pumps	2	Liquid temperature °C	20
3	Flow m ³ /h		Kin. viscosity cSt	1.005
4	Head m		Vapour pressure kPa	2.34
5	Geodetic head m		PH value	
6	Inlet pressure kPa	0	Density kg/m ³	998.3
7	Available system NPSH	Ask our technical department.	Solids Weight %	0
8	Ambient temperature °C	20	Installation height m	100

Booster Set

9	Booster set name	2GP MATRIX 5-4T/0,9	Frequency Hz	50	
10	Design	Booster Set			
11	Manufacturer	EBARA	Impeller Dia.	Max. mm	97
12	Speed rpm	2850		Designed mm	97
13	No. of Stage	4		Min. mm	97
14	Connection Suction side	G2 PN10	Flow	Operating m ³ /h	
15	Connection Discharge side	G1 1/2 PN10		Max- m ³ /h	7.8
16	Max Working Pressure kPa	1000		Min- m ³ /h	1.8
17	Shut-off head kPa	450.60	Head	Operating m	
18	Total weight kg	See the table of "Dimensions".		- (Qmax.) m	17.6
19	Shaft power kW			- (Qmin.) m	43.0
20			Max. Shaft Power at max. impeller kW	0.87	
21	Required NPSH m		Efficiency %		

Materials

22	Frame	Galvanized steel	External pump casing	AISI 304
23	Manifold	AISI 304	Shaft	AISI 304
24	Check valve	Brass / NBR	Shaft seal	Ceramic/Carbon/EPDM
25	Ball valve	Brass / PTFE	O-ring	EPDM
26	Impeller	AISI 304		
27	Casing	AISI 304		

Motor

28	Manufacturer	EPE Standard	Insulation class	F
29	Type	TEFC_MATRIX 5-4T/0.9_400_Three Phase	Phases	3~
30	Specific design	IE3 / 50 Hz / Pole pairs 1	Frame size	
31	Rated power kW	0.9	Weight; motor kg	
32	Number of poles	2	Electric voltage V	400
33	Speed rpm	2850	Electric current A	2.5
34	Degree of protection	IP 55		
35				

Remarks

--

Performance curve

Booster set name
2GP MATRIX 5-4T/0,9

Customer	Date	09.06.2024	Company
Contact	Item no.		Issued by
Phone	Project		Phone
E-mail	Project ID		E-mail

Requested data

1	Flow	m³/h	
2	Head	m	
3	Geodetic head	m	

Booster set

Operating flow	m³/h		Frequency	Hz	50
Operating head	m		Number of poles		2
ImpellerDiameter Designed	mm	97	Speed	rpm	2850

Test standard: ISO 9906:2012 - Grade3B

Water; 20°C; 998.3kg/m³; 1cSt

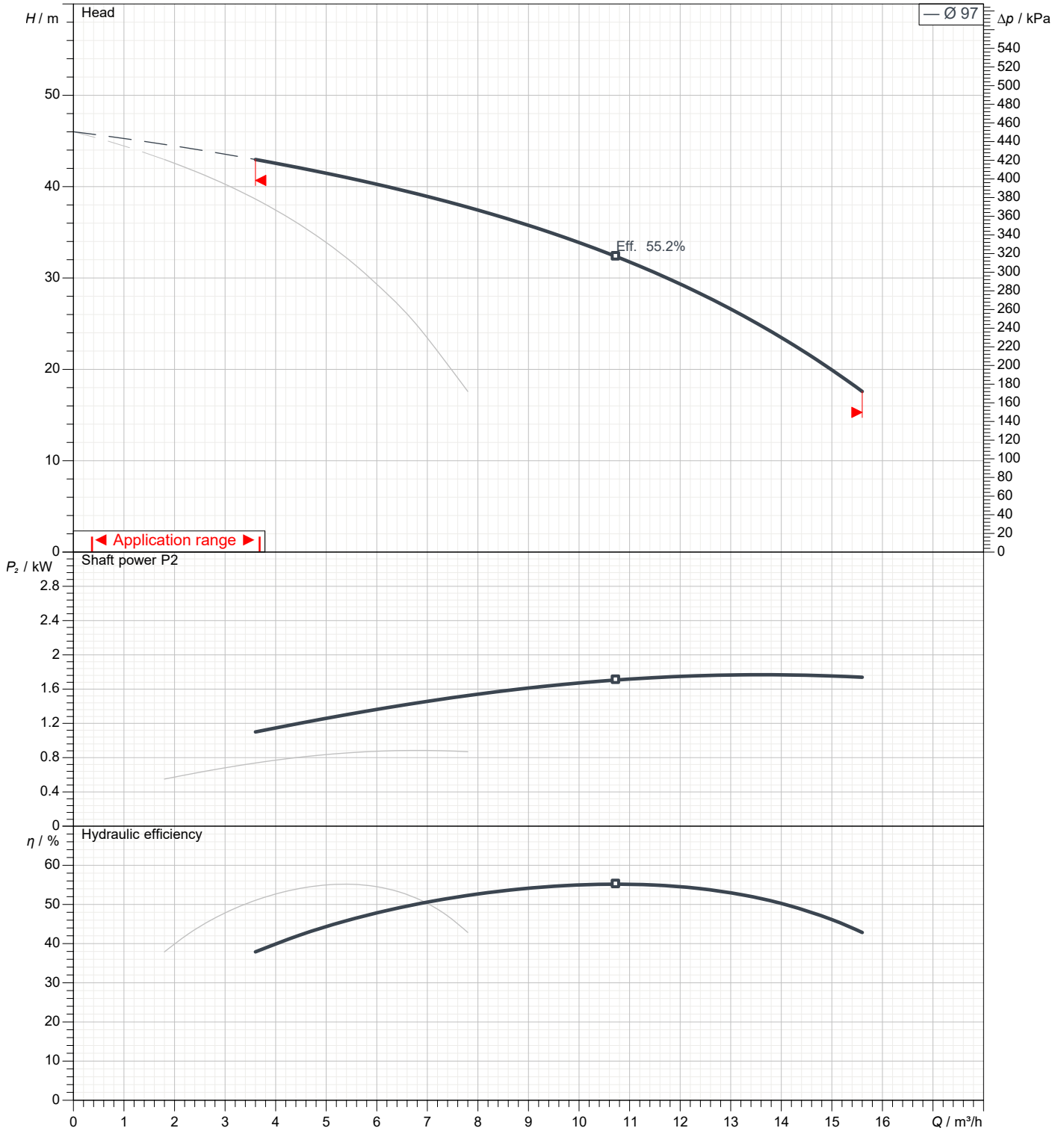

Dimensions

Booster set name

2GP MATRIX 5-4T/0,9

Customer	Date 09.06.2024	Company
Contact	Item no.	Issued by
Phone	Project	Phone
E-mail	Project ID	E-mail

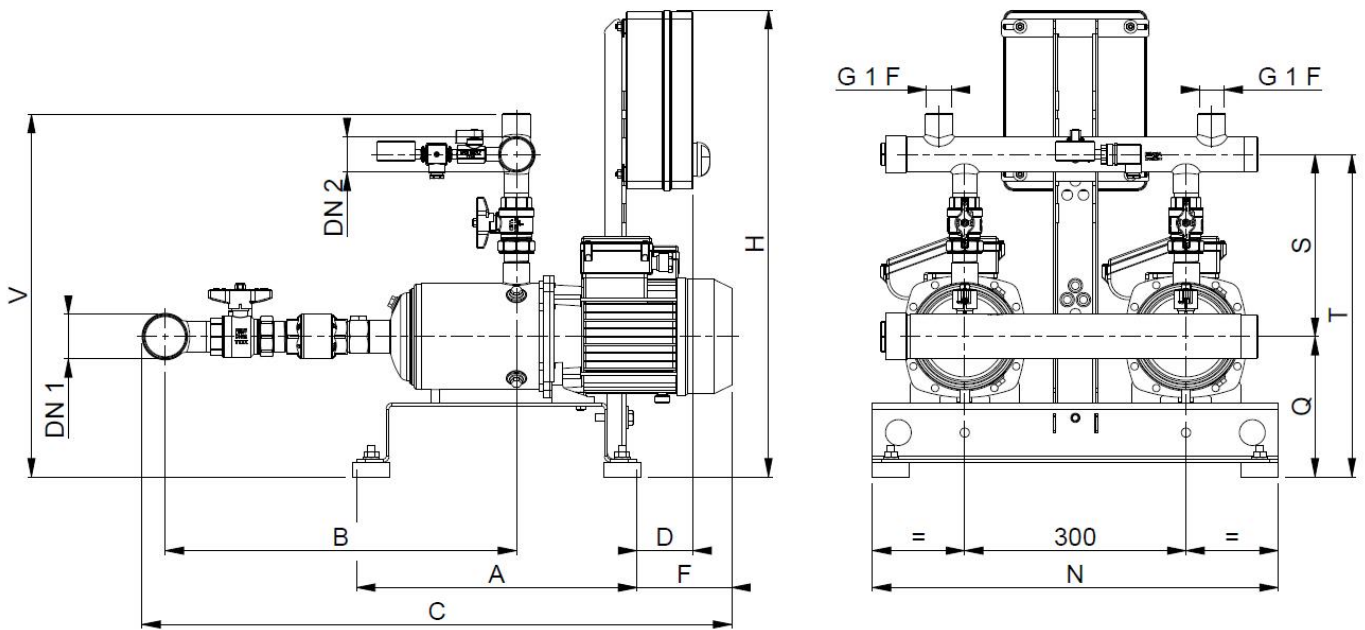

Dimensions in		mm						
1	A	380						
2	B	405						
3	C	785						
4	D	25						
5	DN1	G2						
6	DN2	G1 1/2						
7	F	105						
8	H	635						
9	N	550						
10	Q	190						
11	S	245						
12	T	435						
13	V	490						
14	Weight kg	59						
15								

(1/2) Construction

Booster set name
2GP MATRIX 5-4T/0,9

Customer	Date 09.06.2024	Company
Contact	Item no.	Issued by
Phone	Project	Phone
E-mail	Project ID	E-mail

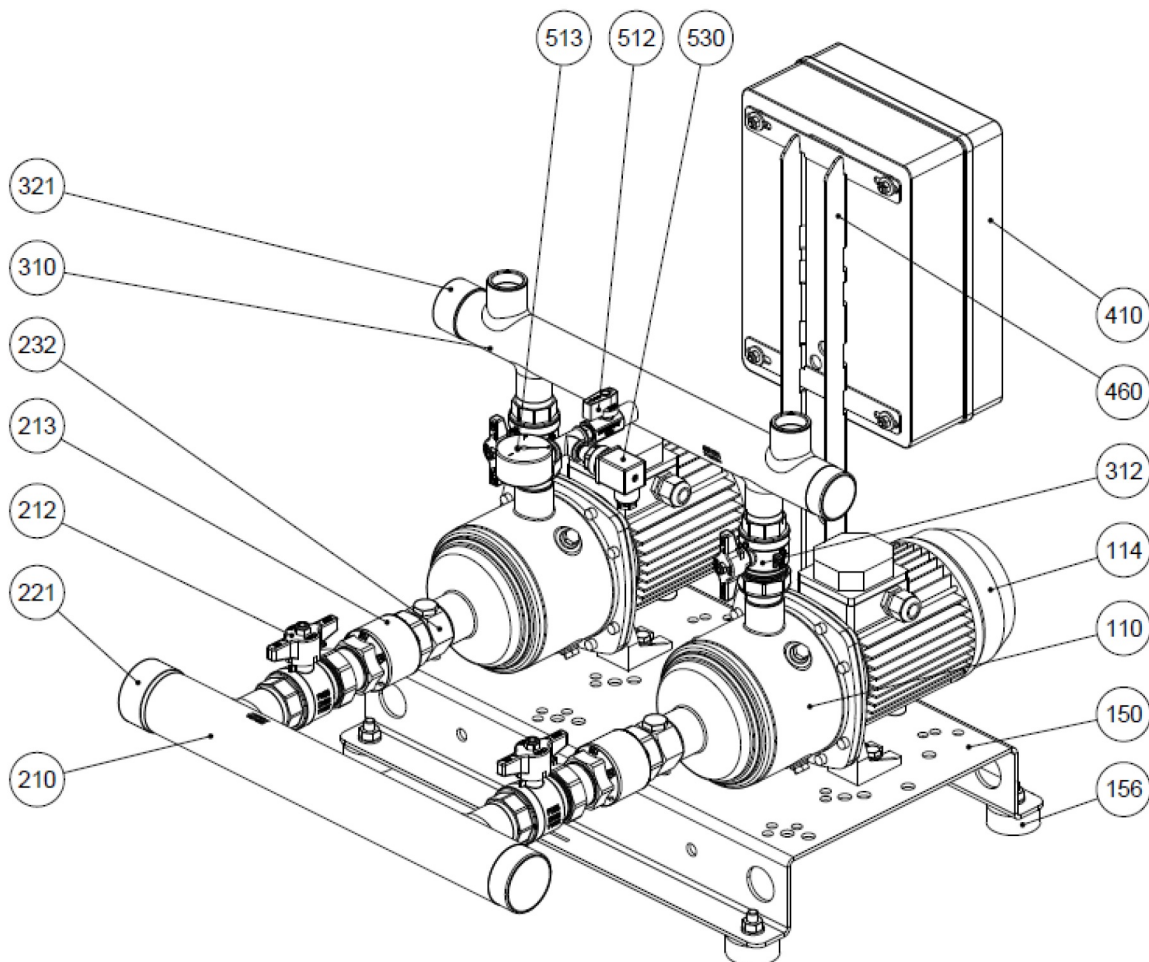

N°	PART NAME	MATERIAL	Quantity
110	Principal pump	-	2
114	Electric motor	-	2
150	Basement	Galvanized steel	1
156	Basement foot	SBR	4
210	Suction manifold	AISI 304	1
212	Union ball valve	Brass / P.T.F.E.	2
213	Check valve	Brass / NBR	2
221	Threaded female cap	AISI 304	1
232	Nipple for air feeders	Yellow brass	2
310	Discharge manifold	AISI 304	1
312	Union ball valve	Brass / P.T.F.E.	2
321	Threaded female cap	AISI 304	1
410	Control panel	-	1
460	Control panel frame	Galvanized steel	1
512	Ball valve	Brass / P.T.F.E.	1
513	Pressure gauge	Copper alloy / plastic	1
530	Pressure transmitter	-	1

(2/2)
Construction

Booster set name
2GP MATRIX 5-4T/0,9

Customer	Date 09.06.2024	Company
Contact	Item no.	Issued by
Phone	Project	Phone
E-mail	Project ID	E-mail

MECHANICAL SEAL

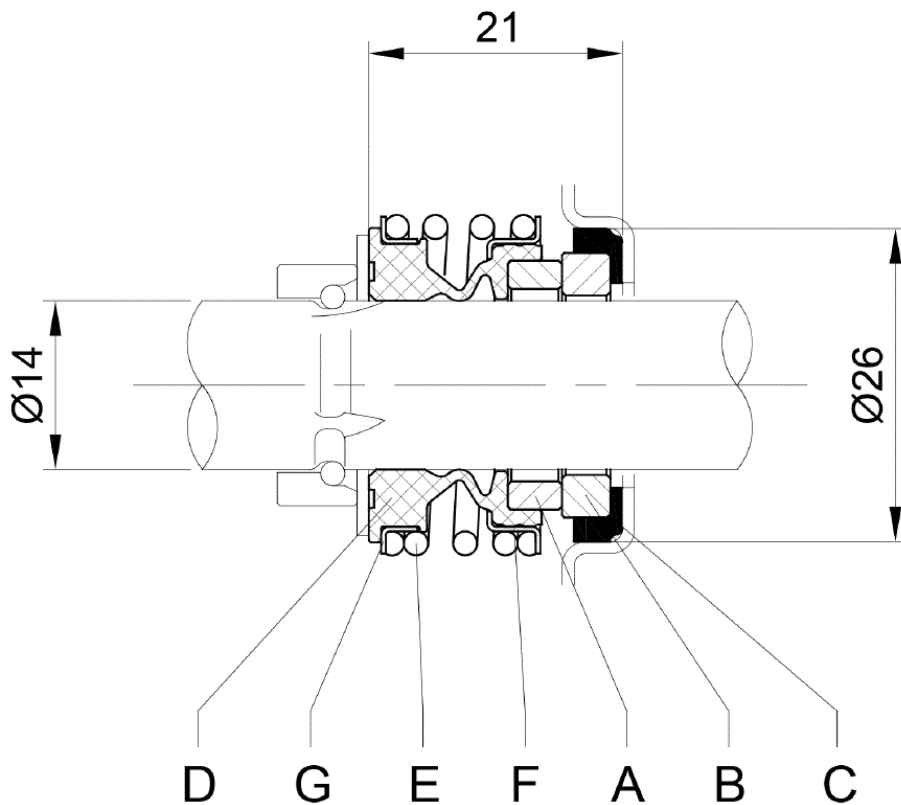

STANDARD*	A	B	C	Material	E	F	G
	Rotary seal ring	Stationary seal ring	Gasket	D Bellows	Spring	Frame	Retainer ring
	Carbon	Ceramic	EPDM	EPDM	EN 1.4402 (AISI 316)	EN 1.4402 (AISI 316)	EN 1.4402 (AISI 316)

*Approval for drinking water application
WRAS Approval product

