

# Technical Data

Pump Name

3D4 65-200/3.0

Customer	Date	09.06.2024	Company
Contact	Item no.		Issued by
Phone	Project		Phone
E-mail	Project ID		E-mail

## Requested data

1	Pump type	CENTRIFUGAL PUMPS	Fluid	Water
2	Number of pumps / Reserve	1 / 0	Liquid temperature	°C
3	Flow	m³/h	Kin. viscosity	cSt
4	Head	m	Vapour pressure	kPa
5	Geodetic head	m	PH value	
6	Inlet pressure (pin)	kPa	Density	kg/m³
7	Available system NPSH		Solids	Weight %
8	Ambient temperature	°C		

## Pump

9	Pump Name	3D4 65-200/3.0	Frequency	Hz	50	
10	Design	CENTRIFUGAL PUMPS	Installation type		STANDARD	
11	Manufacturer	EBARA	Impeller Diameter	Max.	mm	
12	Speed	rpm		1400	Designed	mm
13	No. of Stage	1		Min.	mm	212
14	Connection	Suction side	UNI 2236-67	Flow	Operating	m³/h
15	Connection	Discharge side	EN 1092-2		Max-	m³/h
16	Max Working Pressure	kPa	1000		Min-	m³/h
17	Shut-off head	kPa	159.62	Head	Operating	m
18	Total weight	kg	See the table of "Dimensions".		- (Qmax.)	m
19	Shaft power	kW			- (Qmin.)	m
20				Max. Shaft Power at max. impeller	kW	2.67
21	Required pump NPSH	m		Efficiency	%	

## Materials

22	Casing	Cast iron		
23	Impeller	AISI 316		
24	Shaft	AISI 304		
25				
26				
27				

## Motor

28	Manufacturer	EPE Standard	Insulation class	F	
29	Type	TEFC_3D465-200/3.0_230_Three Phase	Phases	3~	
30	Specific design	IE2 / 50 Hz / Pole pairs 2	Frame size		
31	Rated power	kW	3	Weight	kg
32	Number of poles	4	Electric voltage	V	230
33	Speed	rpm	1400	Electric current	A
34	Degree of protection	IP 55			11.8
35					

## Remarks

# Performance Curve

Pump Name

3D4 65-200/3.0

Customer	Date	09.06.2024	Company
Contact	Item no.		Issued by
Phone	Project		Phone
E-mail	Project ID		E-mail

## Requested data

1	Flow	m³/h	
2	Head	m	
3	Geodetic head	m	

## Pump

Operating flow	m³/h		Frequency	Hz	50
Operating head	m		Number of poles		4
Impeller diameter designed	mm	212	Speed	rpm	1400

Test standard: ISO 9906:2012 - Grade3B

Water; 20°C; 998.3kg/m³; 1cSt

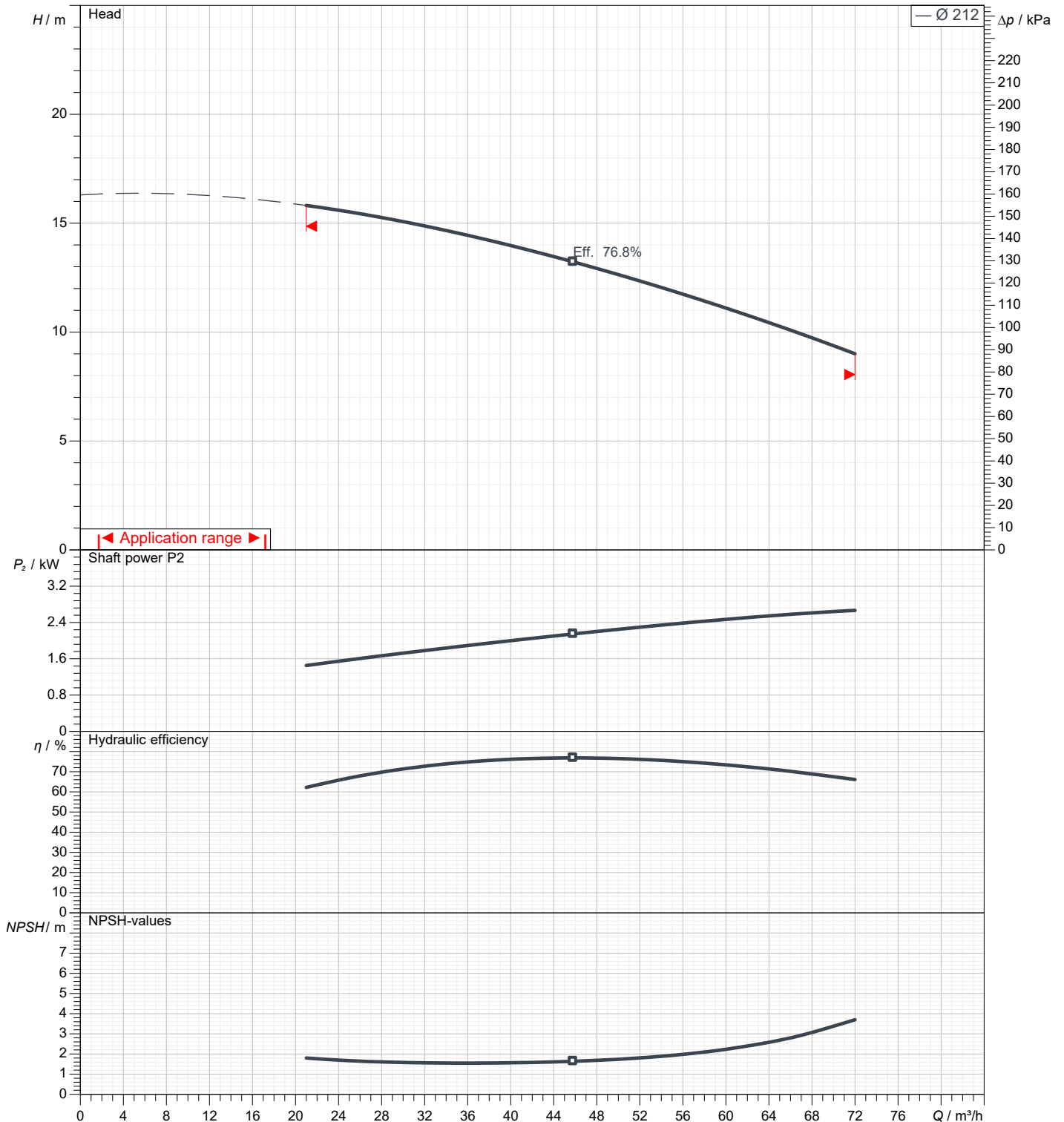

# Dimensions

Pump Name 3D4 65-200/3.0

Customer	Date 09.06.2024	Company
Contact	Item no.	Issued by
Phone	Project	Phone
E-mail	Project ID	E-mail

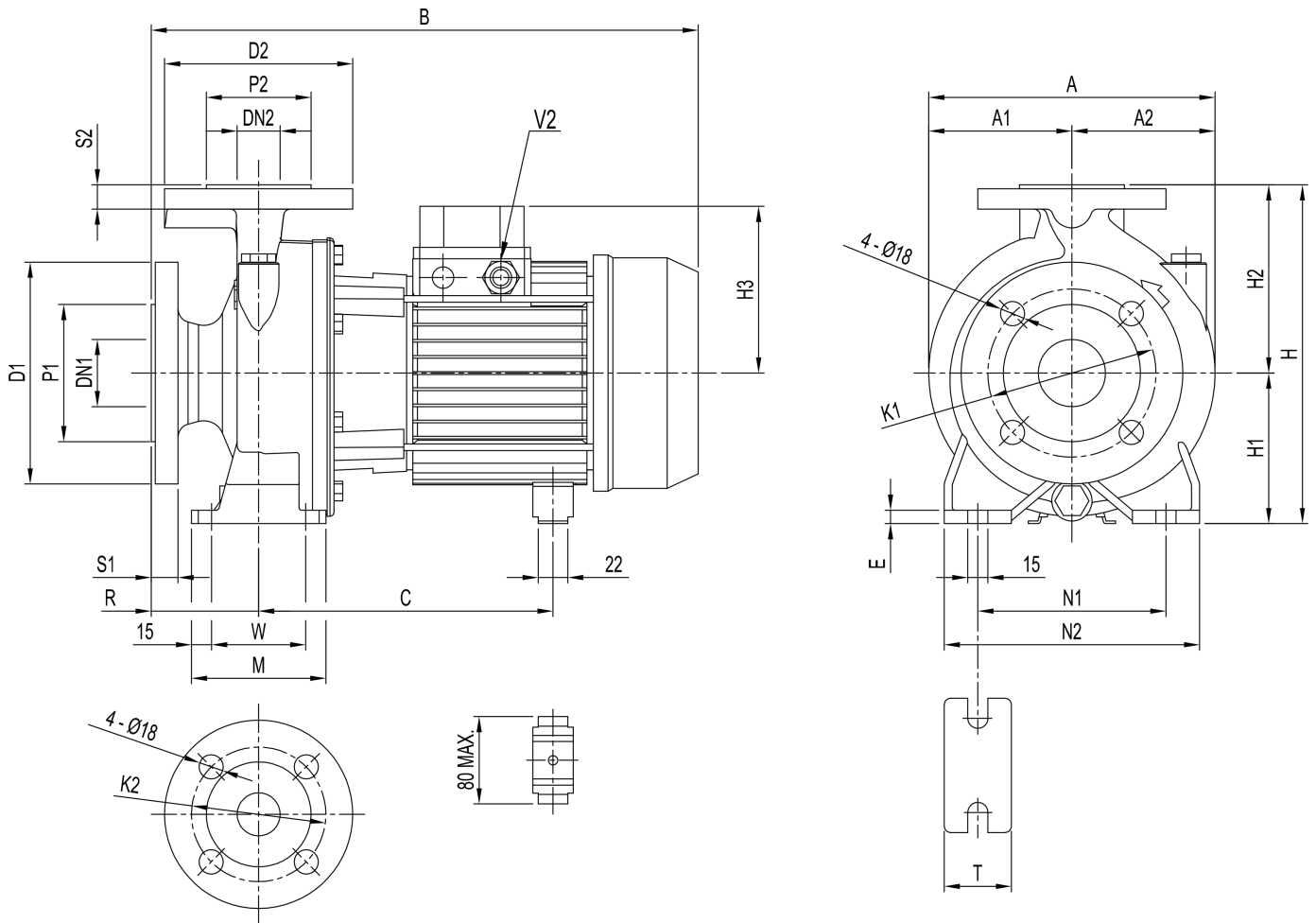

Dimensions in		mm		
1	A	312	M	125
2	A1	154.5	N1	250
3	A2	157.5	N2	320
4	Dia D1	200	R	100
5	Dia D2	185	S1	22
6	Dia DN1	80	S2	20
7	Dia DN2	65	T	65
8	Dia K1	160	W	95
9	Dia K2	145	Weight P&M	54.5 kg
10	Dia P1	138		
11	Dia P2	122		
12	E	12		
13	H	405		
14	H1	180		
15	H2	225		

(1/3)

# Construction

Pump Name 3D4 65-200/3.0

Customer	Date 09.06.2024	Company
Contact	Item no.	Issued by
Phone	Project	Phone
E-mail	Project ID	E-mail

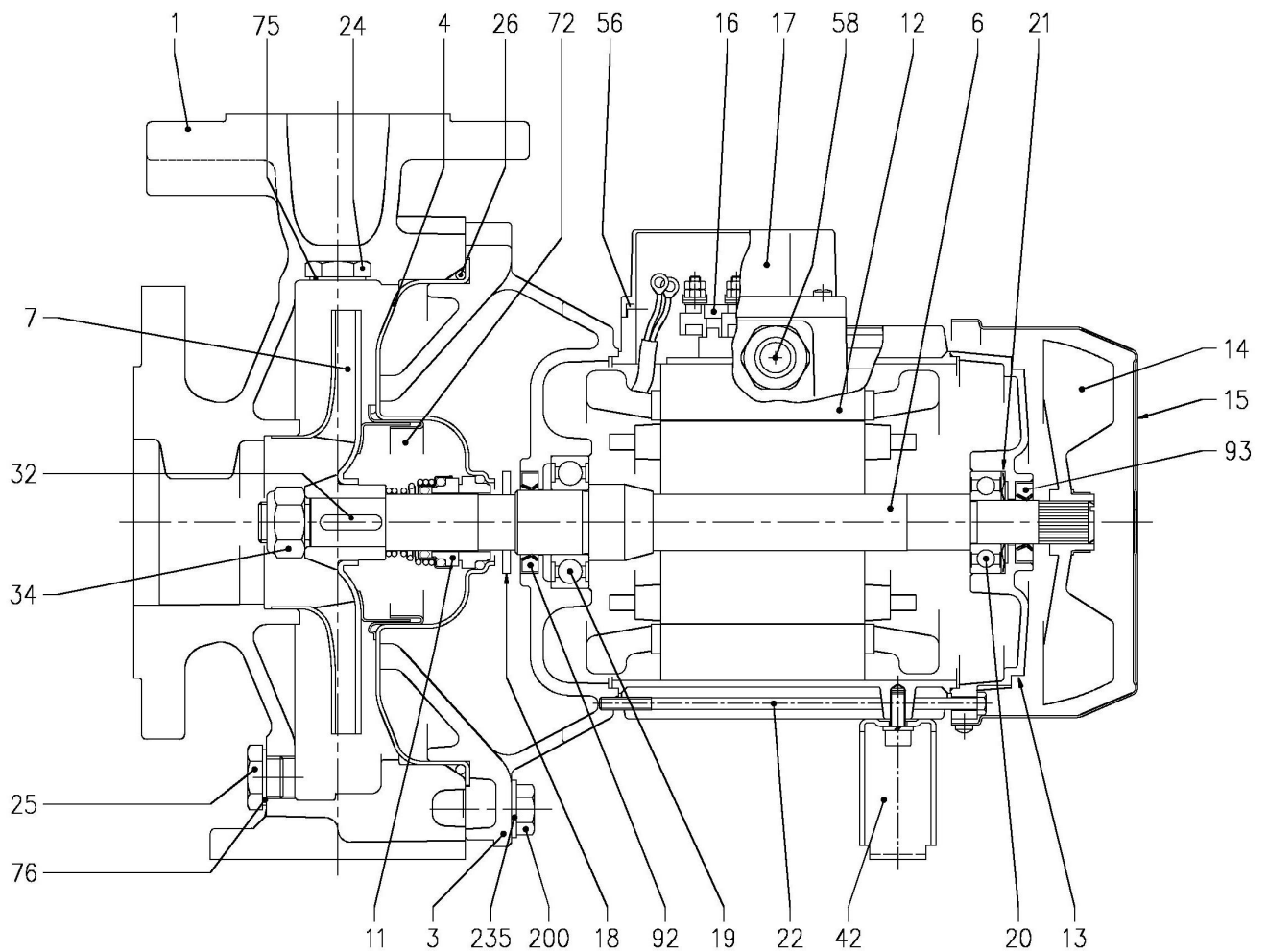

**(2/3)****Construction****Pump Name 3D4 65-200/3.0**

Customer	Date 09.06.2024	Company
Contact	Item no.	Issued by
Phone	Project	Phone
E-mail	Project ID	E-mail

N°	PART NAME	MATERIAL	DIMENSIONS	STANDARD	Q.TY	
001	Casing	Cast iron EN-GJL-250-EN 1561			1	
003	Motor bracket	[1]			1	
004	Casing cover	EN 1.4301 (AISI 304)			1	
006	Shaft with rotor - Wet extension	EN 1.4301 (AISI 304)			1	
007	Impeller	[2]			1	
011	Mechanical seal	[3]	[3]		1	
012	Motor frame with stator	-			1	
013	Motor cover	Aluminium			1	
014	Fan	PA			1	
015	Fan cover	Fe P04 Galvanized			1	
016	Terminal	-			1	
017	Terminal box cover	Aluminium (three phase version)			1	
018	Splash ring	NBR	40x21.5x2	EBARA DRAWING	1	
019	Bearing	-			1	
020	Bearing	-			1	
021	Adjusting ring	Steel C70			1	
022	Tie rod	Fe 42 Galvanized	M5	EBARA DRAWING	4	
24	Priming plug	Brass	G 3/8" L=8		1	
25	Draing plug	Brass	G 3/8" L=8		1	
026	"O" ring	NBR [4]	32-125, 40-125	158.11x5.34	OR 6625	1
			32-160, 40-160, 50-125, 65-125	183.52x5.34	OR 6720	
			32-200, 40-200, 50-160, 50-200, 65-160, 65-200	227.96x5.34	OR 6895	
032	Key	EN 1.4401 (AISI 316)	A 6x6x25	UNI 6604	1	
034	Impeller nut	Other models 50-200/2.2	EN 1.4301 (AISI 304)	M16x1.5	UNI 7474	1
				M18x1.5		
042	Foot	Aluminium / Galvanized steel		EBARA DRAWING	1	
056	Box gasket	NBR			1	
058	Cable gland	-			1	
072	Casing ring [5]	EN 1.4301 (AISI 304)			1	
075	Washer	Aluminum	22x17x1.5	EBARA DRAWING	1	
076	Washer	Aluminum				
092	Lip seal	Up to 1.5 kW For 2.2 to 3 kW	-	25x40x7	DIN 3760 without spring	1
				30x47x7		
093	Lip seal	For 0.25 kW For 0.37 kW and 0.55 kW For 0.75 kW to 3 kW	-	15x30x5	DIN 3760 without spring	1
				17x32x7		
				25x40x7		
200	Screw	Gv. Steel 8.8 strenght class ISO 898-1	M 8x30	UNI 5739	8	
					10	
					M 10x35	12
						10
						12
						10
235	Washer	Galvanized Steel	8.4x17	UNI 6592	8	
					10.5x21	10
						10
						12
						12

[1] Aluminum AL-EN-1706-AC-46000-D for 3D4 50-200/2.2; 65-125/0.75 and 1.1; 65-160/2.2; 65-200/2.2 and 3 kW

Cast iron EN-GJL-200-EN 1561 for all the others;

[2] EN 1.4301 (AISI 304) for 32, 40, 50 series;  
EN 1.4401 (AISI 316) for 65 series

[3] For special version and dimensions see **CONSTRUCTION 3**

[4] FPM for H, HS, HW, HSW version;  
EPDM for E version

[5] Only for: 32-200, 40-200, 50-160, 50-200

(3/3)

# Construction

Pump Name 3D4 65-200/3.0

Customer	Date 09.06.2024	Company
Contact	Item no.	Issued by
Phone	Project	Phone
E-mail	Project ID	E-mail

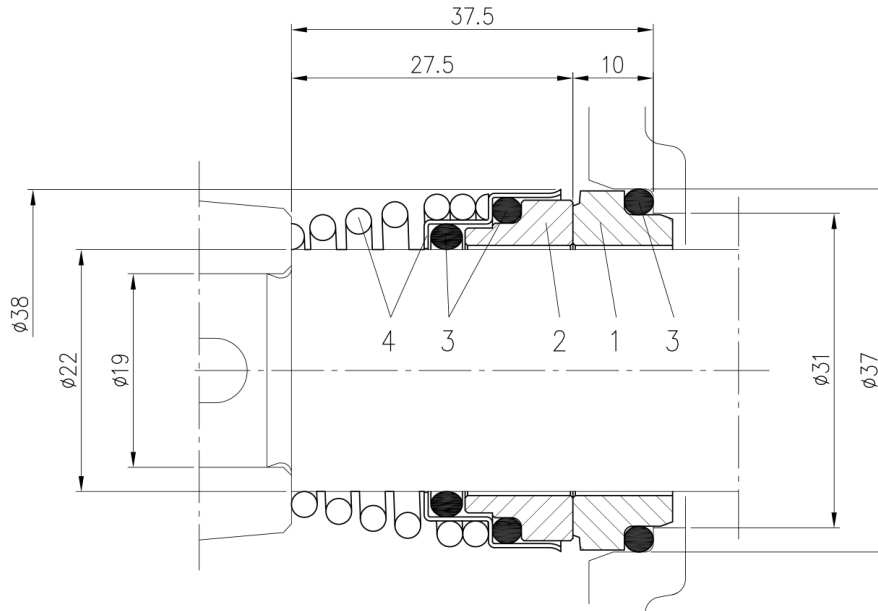

Version	Material			
	1 Stationary seal ring	2 Rotary seal ring	3 Rubber	4 Frame + Spring
Standard	Carbon	Ceramic	NBR	EN 1.4401 (AISI 316)