

Technical Data

Pump Name

3DP4 50-200/1.5

Customer	Date	09.06.2024	Company
Contact	Item no.		Issued by
Phone	Project		Phone
E-mail	Project ID		E-mail

Requested data

1	Pump type	CENTRIFUGAL PUMPS	Fluid	Water
2	Number of pumps / Reserve	1 / 0	Liquid temperature	°C 20
3	Flow m³/h		Kin. viscosity	cSt 1.005
4	Head m		Vapour pressure	kPa 2.34
5	Geodetic head m		PH value	
6	Inlet pressure (pin) kPa	0	Density	kg/m³ 998.3
7	Available system NPSH		Solids	Weight % 0
8	Ambient temperature °C	20		

Pump

9	Pump Name	3DP4 50-200/1.5	Frequency	Hz 50
10	Design	CENTRIFUGAL PUMPS	Installation type	STANDARD
11	Manufacturer	EBARA	Impeller Diameter	Max. mm 200
12	Speed rpm	1400		Designed mm 200
13	No. of Stage	1		Min. mm 200
14	Connection Suction side	EN 1092-2	Flow	Operating m³/h
15	Connection Discharge side	EN 1092-2		Max- m³/h 39
16	Max Working Pressure kPa	1000		Min- m³/h 12
17	Shut-off head kPa	137.11	Head	Operating m
18	Total weight kg	See the table of "Dimensions".		- (Qmax.) m 8.4
19	Shaft power kW			- (Qmin.) m 13.3
20			Max. Shaft Power at max. impeller	kW 1.25
21	Required pump NPSH m		Efficiency	%

Materials

22	Casing	Cast iron		
23	Impeller	AISI 304		
24	Shaft	AISI 304		
25				
26				
27				

Motor

28	Manufacturer	LAFERT	Insulation class	F
29	Type	TEFC_3DP450-200/1.5_230_Three Phase	Phases	3~
30	Specific design	IE3 / 50 Hz / Pole pairs 2	Frame size	90 L
31	Rated power kW	1.5	Weight	kg
32	Number of poles	4	Electric voltage	V 230
33	Speed rpm	1400	Electric current	A 5.9
34	Degree of protection	IP 55		
35				

Remarks

Performance Curve

Pump Name

3DP4 50-200/1.5

Customer	Date 09.06.2024	Company
Contact	Item no.	Issued by
Phone	Project	Phone
E-mail	Project ID	E-mail

Requested data

1	Flow	m³/h	
2	Head	m	
3	Geodetic head	m	

Pump

Operating flow	m³/h	Frequency	Hz	50	
Operating head	m	Number of poles	4		
Impeller diameter designed	mm	200	Speed	rpm	1400

Test standard: ISO 9906:2012 - Grade3B

Water; 20°C; 998.3kg/m³; 1cSt

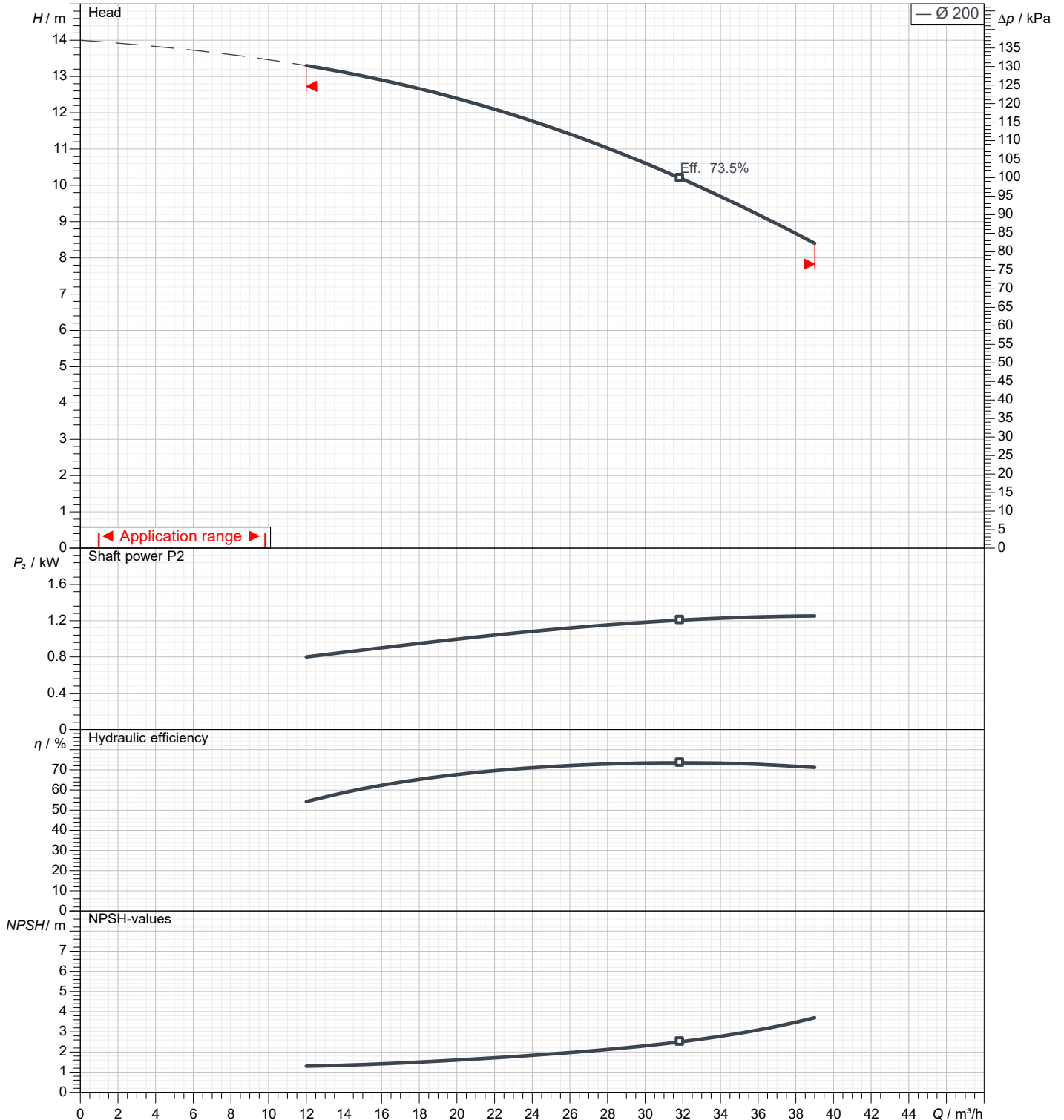

Dimensions

Pump Name 3DP4 50-200/1.5

Customer	Date 09.06.2024	Company
Contact	Item no.	Issued by
Phone	Project	Phone
E-mail	Project ID	E-mail

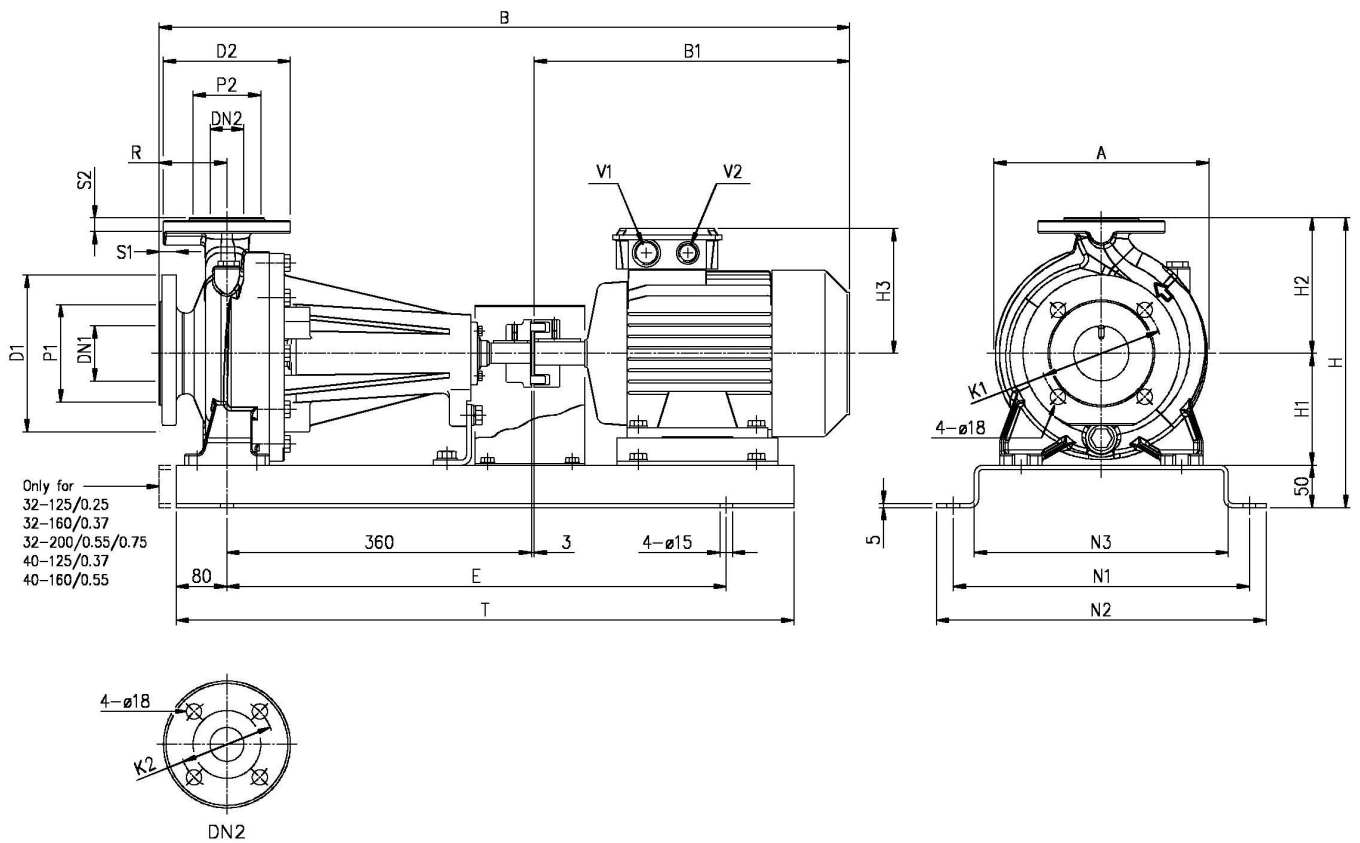

Dimensions in		mm						
1	A	296	H3	148				
2	B	780	N1	350				
3	B	780	N2	390				
4	Dia D1	185	R	100				
5	Dia D2	165	S1	20				
6	Dia DN1	65	S2	20				
7	Dia DN2	50	T	750				
8	Dia K1	145	V1	M25X1.5				
9	Dia K2	125	V2	M20X1.5				
10	Dia P1	122	Weight P&M	79.5 kg				
11	Dia P2	102						
12	E	590						
13	H	410						
14	H1	160						
15	H2	200						

(1/3)

Construction

Pump Name 3DP4 50-200/1.5

Customer	Date 09.06.2024	Company
Contact	Item no.	Issued by
Phone	Project	Phone
E-mail	Project ID	E-mail

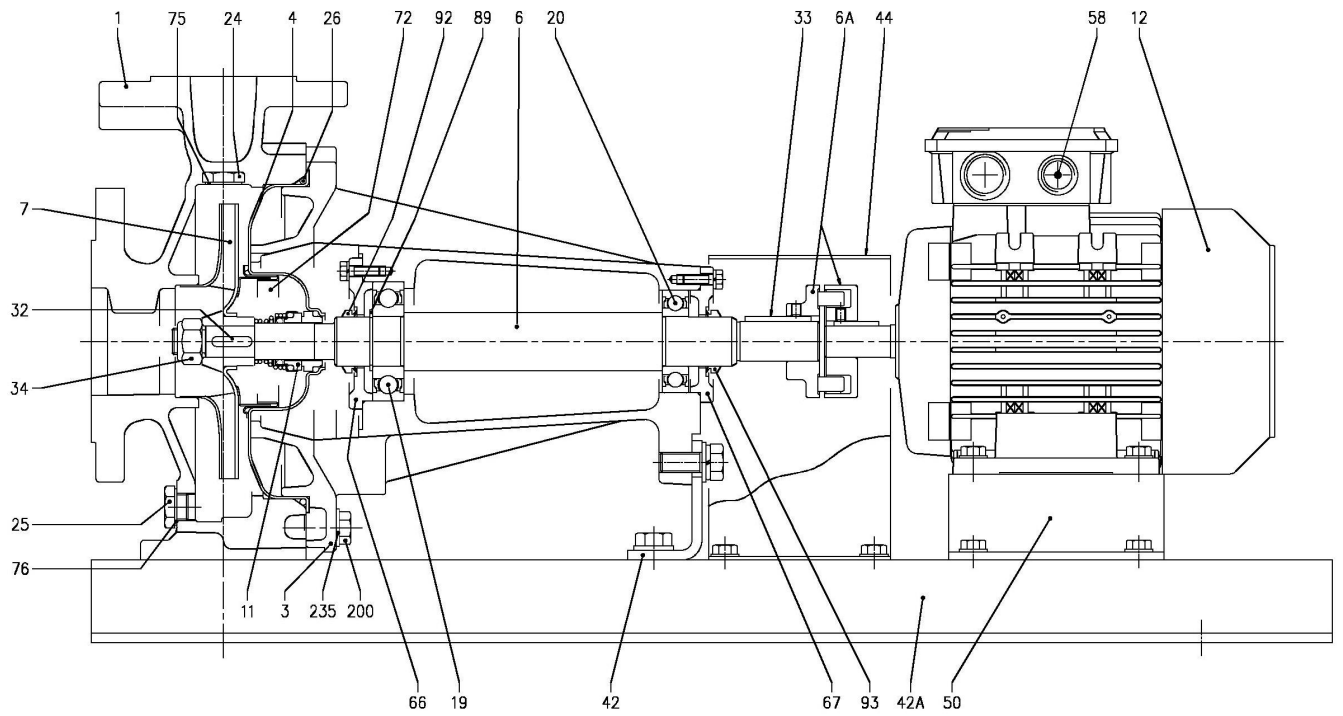

(2/3)**Construction****Pump Name 3DP4 50-200/1.5**

Customer	Date	09.06.2024	Company
Contact	Item no.		Issued by
Phone	Project		Phone
E-mail	Project ID		E-mail

N°	PART NAME		MATERIAL	DIMENSIONS	STANDARD	Q.TY
001	Casing		Cast iron EN-GJL-200-EN 1561			1
003	Support		Cast iron EN-GJL-200-EN 1561			1
004	Casing cover		EN 1.4301 (AISI 304)			1
006	Shaft - Wet extension		EN 1.4301 (AISI 304)			1
006A	Flexible coupling		Cast iron EN-GJL-250-EN 1561			1
007	Impeller		[1]			1
011	Mechanical seal		[2]	[2]		1
012	Motor		-			1
019	Bearing		-			1
020	Bearing		-			1
024	Priming plug		Brass	G 3/8" L=8	DIN 906	1
025	Drain plug		Brass	G 3/8" L=8	DIN 906	1
026	"O" ring	32-125, 40-125	NBR [3]	158.11x5.34	OR 6625	1
		32-160, 40-160, 50-125, 65-125		183.52x5.34	OR 6720	
		32-200, 40-200, 50-160, 50-200, 65-160, 65-200		227.96x5.34	OR 6895	
032	Key		EN 1.4401 (AISI 316)	6x6x25	UNI 6604	1
033	Key		C 40	8x7x40	UNI 6604	1
034	Impeller nut	Other models	EN 1.4301 (AISI 304)	M16x1.5	UNI 7474	1
		50-200/2.2		M18x1.5		
042	Pump support		Fe 37 Galvanized		EBARA DRAWING	1
042A	Base		Fe 37 Galvanized			1
044	Protection		Fe 37 Galvanized			1
050	Foot		Aluminium / Galvanized steel			1
058	Cable gland		-			1
066	Impeller side bearing cover		Cast iron EN-GJL-200-EN 1561			1
067	Motor side bearing cover		Cast iron EN-GJL-200-EN 1561			1
072	Casing ring [4]		EN 1.4301 (AISI 304)			1
075	Washer		Aluminum	22x17x1.5	EBARA DRAWING	1
076	Washer		Aluminum	22x17x1.5	EBARA DRAWING	1
089	Snap ring	32-125, 32-160	Carbon tool steel TC 80	Ø30	UNI 7435	1
		40-125				
		50-125				
		Other models		Ø40		
092	"V" ring		-	VS - 0030		1
093	"V" ring		-	VS - 0030		1
200	Screw	32-125	Gv. Steel 8.8 strenght class ISO 898-1	M 8x30	UNI 5739	8
		40-125				
		32-160				
		40-160				
		50-125				
65-125	M 10x35	10				
32-200, 40-200						
50-160, 50-200						
65-160, 65-200		12				
235	Washer	32-125	Galvanized Steel	8.4x17	UNI 6592	8
		40-125				
		32-160				
		40-160				
		50-125				
		65-125				
32-200, 40-200						
50-160, 50-200						
65-160, 65-200		12				

[1] EN 1.4301 (AISI 304) for 32, 40, 50 series;

EN 1.4401 (AISI 316) for 65 series

[2] See **CONSTRUCTION 3**

[3] FPM for H, HS, HW, HSW version;

EPDM for E version

[4] Only for: 32-200, 40-200, 50-160, 50-200

(3/3)

Construction

Pump Name 3DP4 50-200/1.5

Customer	Date 09.06.2024	Company
Contact	Item no.	Issued by
Phone	Project	Phone
E-mail	Project ID	E-mail

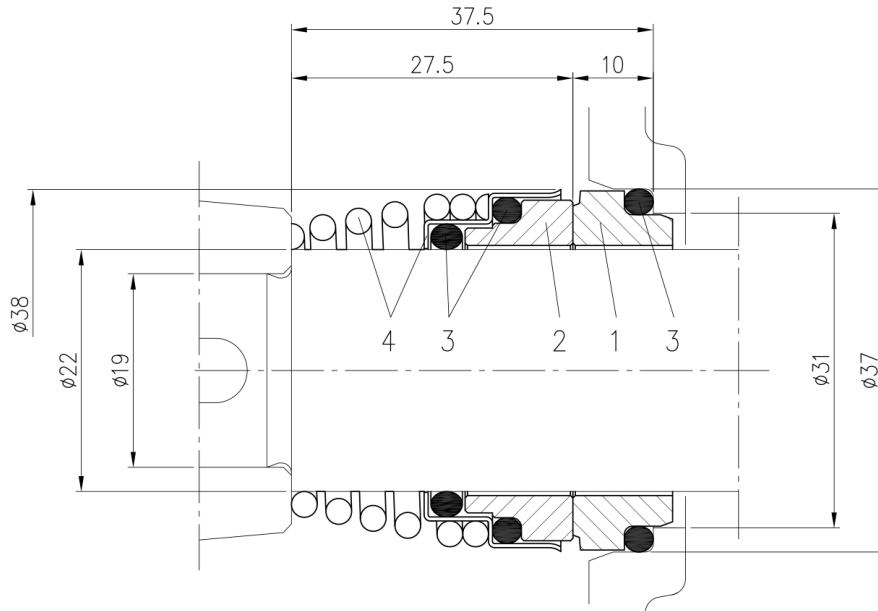

Version	Material			
	1 Stationary seal ring	2 Rotary seal ring	3 Rubber	4 Frame + Spring
Standard	Carbon	Ceramic	NBR	EN 1.4401 (AISI 316)