

# Technical Data

Pump Name

3DP 65-160/7.5

Customer	Date	09.06.2024	Company
Contact	Item no.		Issued by
Phone	Project		Phone
E-mail	Project ID		E-mail

## Requested data

1	Pump type	CENTRIFUGAL PUMPS	Fluid	Water
2	Number of pumps / Reserve	1 / 0	Liquid temperature	°C
3	Flow	m³/h	Kin. viscosity	cSt
4	Head	m	Vapour pressure	kPa
5	Geodetic head	m	PH value	
6	Inlet pressure (pin)	kPa	Density	kg/m³
7	Available system NPSH		Solids	Weight %
8	Ambient temperature	°C		

## Pump

9	Pump Name	3DP 65-160/7.5	Frequency	Hz	50	
10	Design	CENTRIFUGAL PUMPS	Installation type		STANDARD	
11	Manufacturer	EBARA	Impeller Diameter	Max.	mm	
12	Speed	rpm		2900	Designed	mm
13	No. of Stage	1		Min.	mm	153
14	Connection	Suction side	EN 1092-2	Flow	Operating	m³/h
15	Connection	Discharge side	EN 1092-2		Max-	m³/h
16	Max Working Pressure	kPa	1000		Min-	m³/h
17	Shut-off head	kPa	309.47	Head	Operating	m
18	Total weight	kg	See the table of "Dimensions".		- (Qmax.)	m
19	Shaft power	kW			- (Qmin.)	m
20			Max. Shaft Power at max. impeller	kW	6.70	
21	Required pump NPSH	m	Efficiency	%		

## Materials

22	Impeller	AISI 316	
23	Casing	Cast iron	
24	Shaft	AISI 304 (wet extension)	
25			
26			
27			

## Motor

28	Manufacturer	LAFERT	Insulation class	F	
29	Type	TEFC_3DP 65-160/7.5_400_Three Phase	Phases	3~	
30	Specific design	IE3 / 50 Hz / Pole pairs 1	Frame size	132 S	
31	Rated power	kW	7.5	Weight	kg
32	Number of poles	2	Electric voltage	V	400
33	Speed	rpm	2900	Electric current	A
34	Degree of protection	IP 55			
35					

## Remarks

# Performance Curve

Pump Name

3DP 65-160/7.5

Customer	Date	09.06.2024	Company
Contact	Item no.		Issued by
Phone	Project		Phone
E-mail	Project ID		E-mail

## Requested data

1	Flow	m³/h	
2	Head	m	
3	Geodetic head	m	

## Pump

Operating flow	m³/h		Frequency	Hz	50
Operating head	m		Number of poles		2
Impeller diameter designed	mm	153	Speed	rpm	2900

Test standard: ISO 9906:2012 - Grade3B

Water; 20°C; 998.3kg/m³; 1cSt

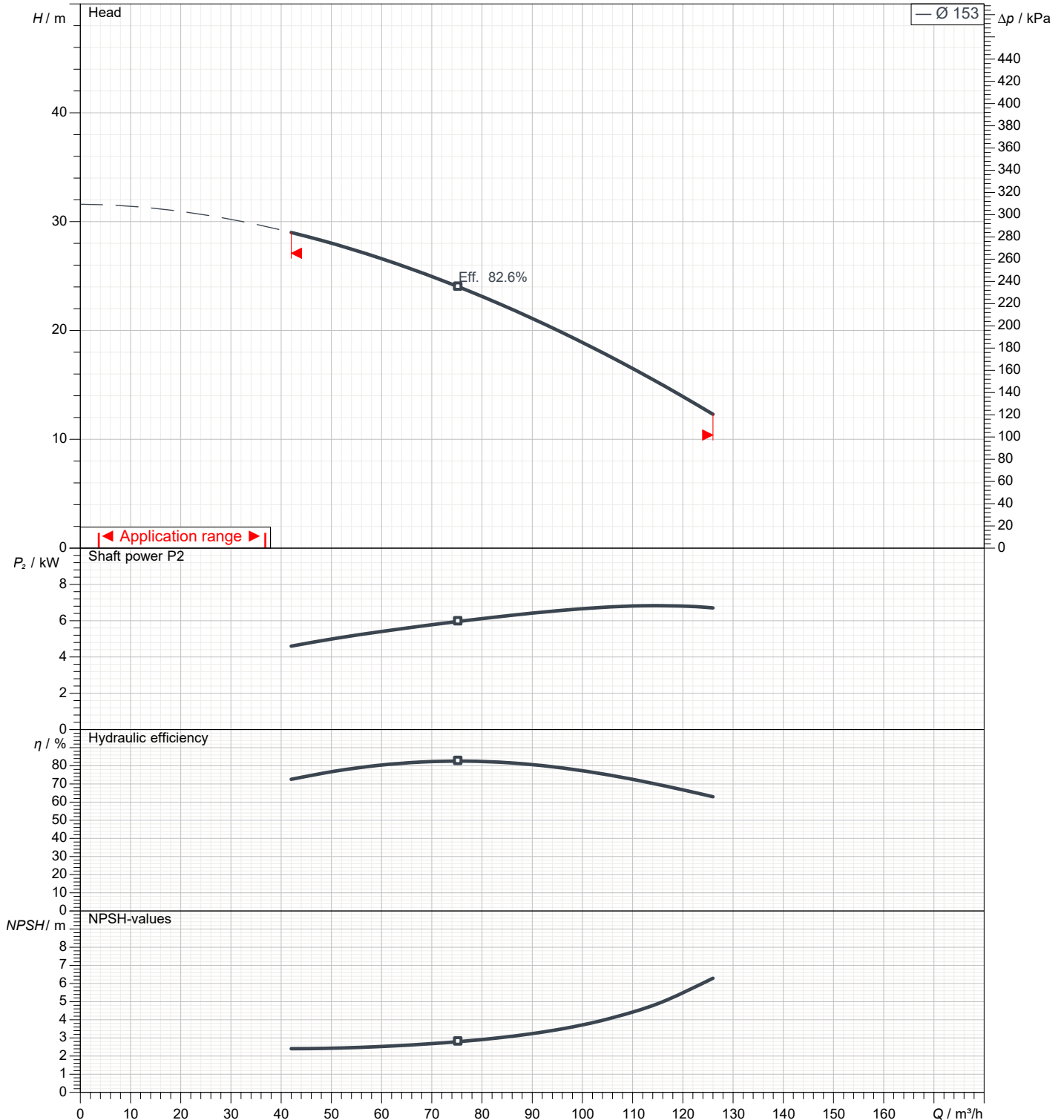

# Dimensions

Pump Name 3DP 65-160/7.5

Customer	Date 09.06.2024	Company
Contact	Item no.	Issued by
Phone	Project	Phone
E-mail	Project ID	E-mail

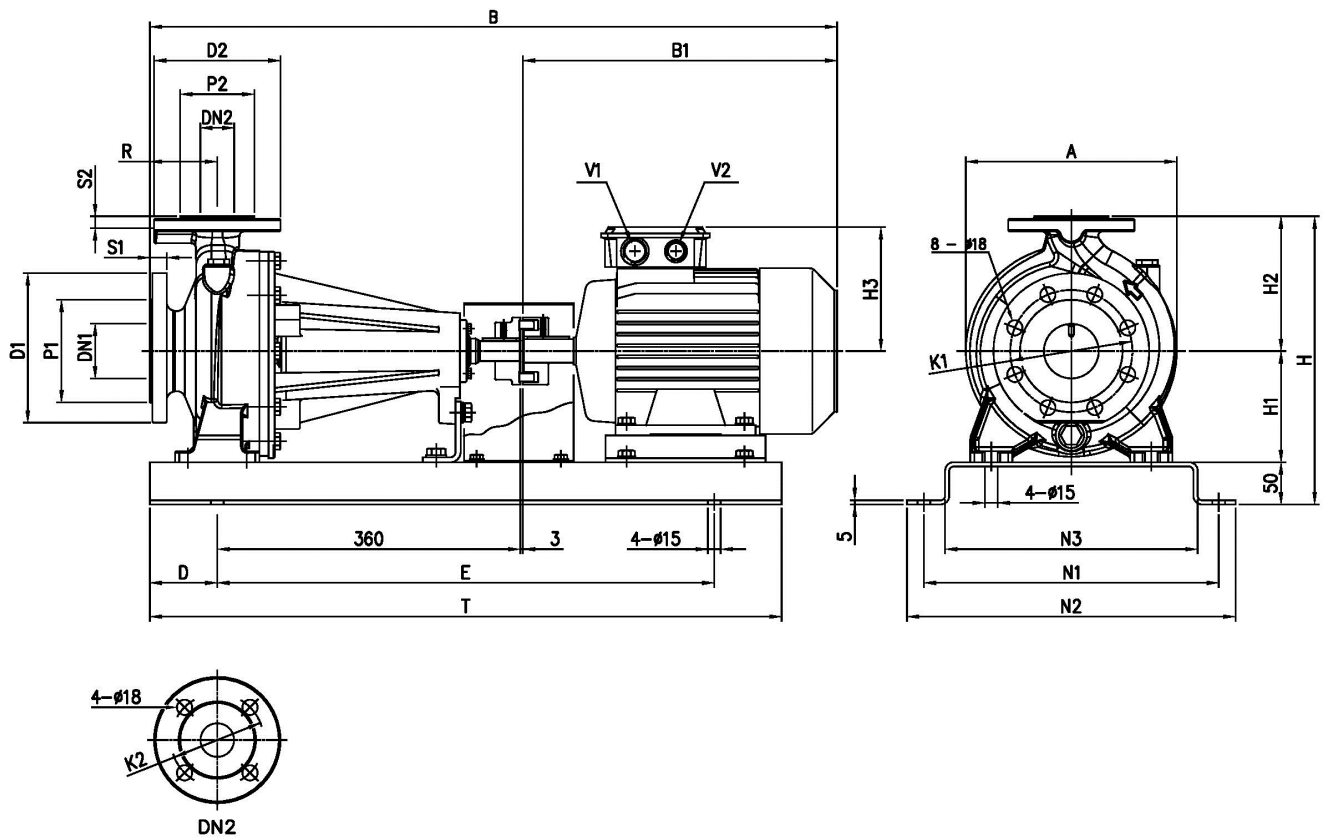

Dimensions in		mm						
1	A	296	H2	200				
2	B	928	H3	198				
3	B1	442	N1	350				
4	D	100	N2	390				
5	Dia D1	200	N3	300				
6	Dia D2	185	R	100				
7	Dia DN1	80	S1	22				
8	Dia DN2	65	S2	20				
9	Dia K1	160	T	850				
10	Dia K2	145	V1	M32x1,5				
11	Dia P1	138	V2	M32x1,5				
12	Dia P2	122	Weight P&M	133.2 kg				
13	E	650						
14	H	410						
15	H1	160						

(1/3)

# Construction

Pump Name 3DP 65-160/7.5

Customer	Date 09.06.2024	Company
Contact	Item no.	Issued by
Phone	Project	Phone
E-mail	Project ID	E-mail

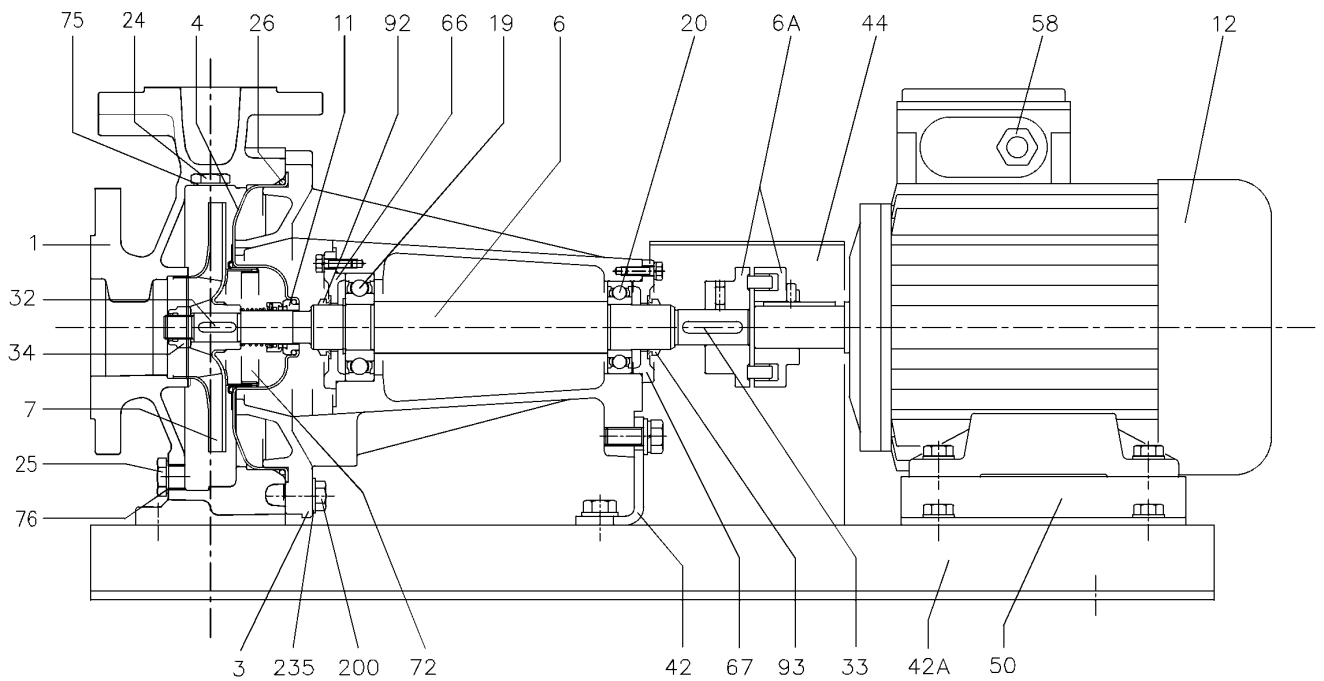

(2/3)

# Construction

Pump Name 3DP 65-160/7.5

Customer	Date 09.06.2024	Company
Contact	Item no.	Issued by
Phone	Project	Phone
E-mail	Project ID	E-mail

N°	PART NAME	MATERIAL	DIMENSIONS	STANDARD	Q.TY	
1	Casing	Cast iron EN-GJL-200-EN 1561			1	
3	Support	Cast iron EN-GJL-200-EN 1561			1	
4	Casing cover	EN 1.4301 (AISI 304)			1	
6	Shaft - Wet extension	EN 1.4301 (AISI 304)			1	
6A	Flexible coupling	Cast iron EN-GJL-250-EN 1561			1	
7	Impeller [1]	-			1	
11	Mechanical seal [2]	-			1	
12	Motor	-			1	
19	Bearing	-			1	
20	Bearing	-			1	
24	Priming plug	Brass	G 3/8" L=8	DIN 906	1	
25	Draing plug	Brass	G 3/8" L=8	DIN 906	1	
26	O-ring [3]	NBR/FPM/EPDM	32-125, 40-125	158.11x5.34	OR 6625	1
			32-160, 40-160, 50-125, 65-125	183.52x5.34	OR 6720	
			32-200, 40-200, 50-160,			
			50-200, 65-160, 65-200	227.96x5.34	OR 6895	
32	Key	EN 1.4401 (AISI 316)	Up to 11 kW	6x6x25	UNI 6604	1
			50-200/15			
			15 kW and above	8x7x30		
33	Key	C 40	8x7x40	UNI 6604	1	
34	Impeller nut	EN 1.4301 (AISI 304)	Up to 11kW	M16x1.5	UNI 7474	1
			50-200/15	M18x1.5		
				M20x1.5		
			15 kW and above			
42	Pump support	Fe 37 Galvanized		EBARA DRAWING	1	
42A	Base	Fe 37 Galvanized			1	
44	Protection	Fe 37 Galvanized			1	
50	Foot	Aluminium / Galvanized steel			1	
58	Cable gland	-			1	
66	Impeller side bearing cover	Cast iron EN-GJL-200-EN 1561			1	
67	Motor side bearing cover	Cast iron EN-GJL-200-EN 1561			1	
72	Casing ring [4]	EN 1.4301 (AISI 304)			1	
75	Washer	Aluminum	22x17x1.5	EBARA DRAWING	1	
76	Washer	Aluminum	22x17x1.5	EBARA DRAWING	1	
92	"V" ring	-	VS - 0030		1	
93	"V" ring	-	VS - 0030		1	
200	Screw	Gv. Steel 8.8 strenght class ISO 898-1	32-125, 40-125	M 8x30	UNI 5739	8
			32-160, 40-160, 50-125, 65-125			10
			32-200, 40-200, 50-160			12
			50-200, 65-160, 65-200	M 10x35		
235	Washer	Galvanized Steel	32-125, 40-125	8.4x17	UNI 6592	8
			32-160, 40-160, 50-125, 65-125			10
			32-200, 40-200, 50-160			12
			50-200, 65-160, 65-200	10.5x21		

[1] EN 1.4301 (AISI 304) for 32, 40, 50 series;  
EN 1.4401 (AISI 316) for 65 series

[2] See **CONSTRUCTION 3**

[3] See **CONSTRUCTION 3**, "O-ring" column

[4] Only for: 32-200, 40-200, 50-160, 50-200

(3/3)

# Construction

Pump Name 3DP 65-160/7.5

Customer	Date 09.06.2024	Company
Contact	Item no.	Issued by
Phone	Project	Phone
E-mail	Project ID	E-mail

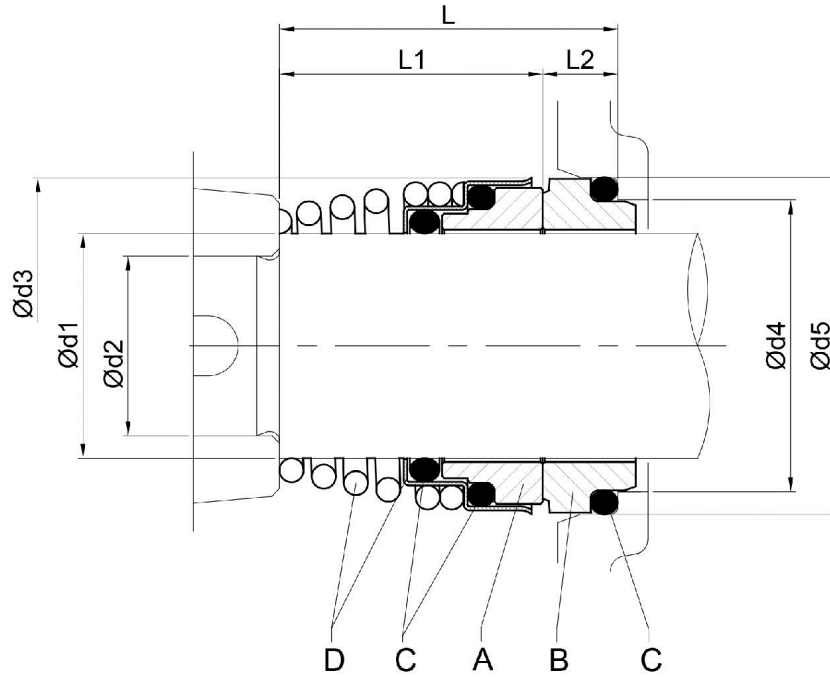

Pump type	Dimensions [ mm ]									Material Standard			
	d1	d2	d3	d4	d5	L	L1	L2	A Rotary seal ring	B Stationary seal ring	C O-ring	D Frame + Spring	
32-125/160/200													
40-125/160/200													
50-125/160/200	22	19	38	31	37	37.5	27.5	10	Ceramic	Carbon	NBR	EN 1.4301 (AISI 304)	
65-125													
65-160/7.5-9.2-11													