

# Technical Data

Pump Name

3DS4 65-160/1.5

Customer	Date	09.06.2024	Company
Contact	Item no.		Issued by
Phone	Project		Phone
E-mail	Project ID		E-mail

## Requested data

1	Pump type	CENTRIFUGAL PUMPS	Fluid	Water
2	Number of pumps / Reserve	1 / 0	Liquid temperature	°C 20
3	Flow m³/h		Kin. viscosity	cSt 1.005
4	Head m		Vapour pressure	kPa 2.34
5	Geodetic head m		PH value	
6	Inlet pressure (pin) kPa	0	Density	kg/m³ 998.3
7	Available system NPSH		Solids	Weight % 0
8	Ambient temperature °C	20		

## Pump

9	Pump Name	3DS4 65-160/1.5	Frequency	Hz 50
10	Design	CENTRIFUGAL PUMPS	Installation type	STANDARD
11	Manufacturer	EBARA	Impeller Diameter	Max. mm 168
12	Speed rpm	1400		Designed mm 168
13	No. of Stage	1		Min. mm 168
14	Connection Suction side	UNI 2236-67	Flow	Operating m³/h
15	Connection Discharge side	EN 1092-2		Max- m³/h 66
16	Max Working Pressure kPa	1000		Min- m³/h 21
17	Shut-off head kPa	94.99	Head	Operating m
18	Total weight kg	See the table of "Dimensions".		- (Qmax.) m 4.5
19	Shaft power kW			- (Qmin.) m 9.2
20			Max. Shaft Power at max. impeller	kW 1.26
21	Required pump NPSH m		Efficiency	%

## Materials

22	Casing	Cast iron	
23	Impeller	AISI 316	
24	Shaft	AISI 304	
25			
26			
27			

## Motor

28	Manufacturer	LAFERT	Insulation class	F
29	Type	TEFC_3DS465-160/1.5_230_Three Phase	Phases	3~
30	Specific design	IE3 / 50 Hz / Pole pairs 2	Frame size	90 L
31	Rated power kW	1.5	Weight	kg
32	Number of poles	4	Electric voltage	V 230
33	Speed rpm	1400	Electric current	A 5.9
34	Degree of protection	IP 55		
35				

## Remarks

# Performance Curve

Pump Name

3DS4 65-160/1.5

Customer	Date	09.06.2024	Company
Contact	Item no.		Issued by
Phone	Project		Phone
E-mail	Project ID		E-mail

## Requested data

1	Flow	m³/h	
2	Head	m	
3	Geodetic head	m	

## Pump

Operating flow	m³/h		Frequency	Hz	50
Operating head	m		Number of poles		4
Impeller diameter designed	mm	168	Speed	rpm	1400

Test standard: ISO 9906:2012 - Grade3B

Water; 20°C; 998.3kg/m³; 1cSt

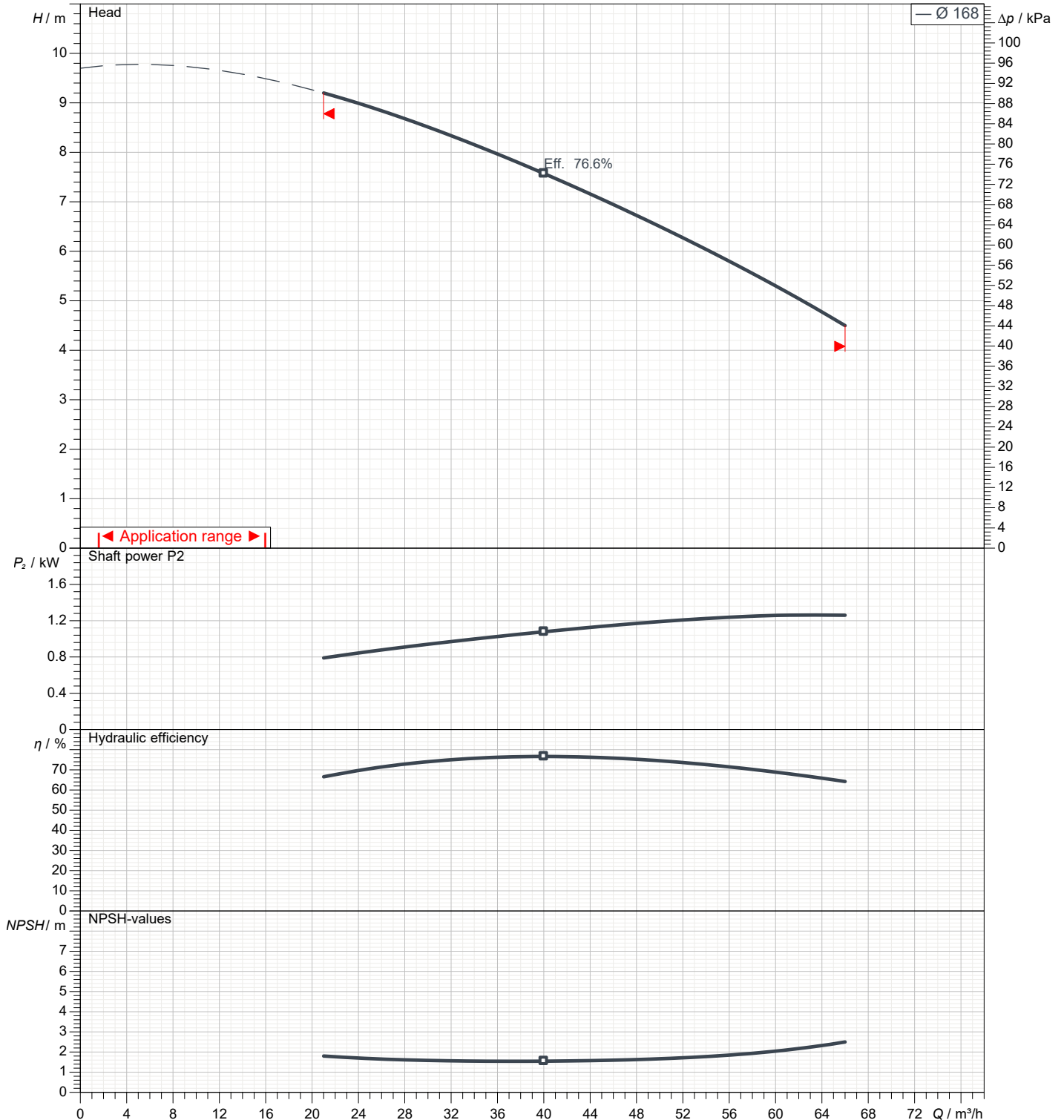

# Dimensions

Pump Name 3DS4 65-160/1.5

Customer	Date 09.06.2024	Company
Contact	Item no.	Issued by
Phone	Project	Phone
E-mail	Project ID	E-mail

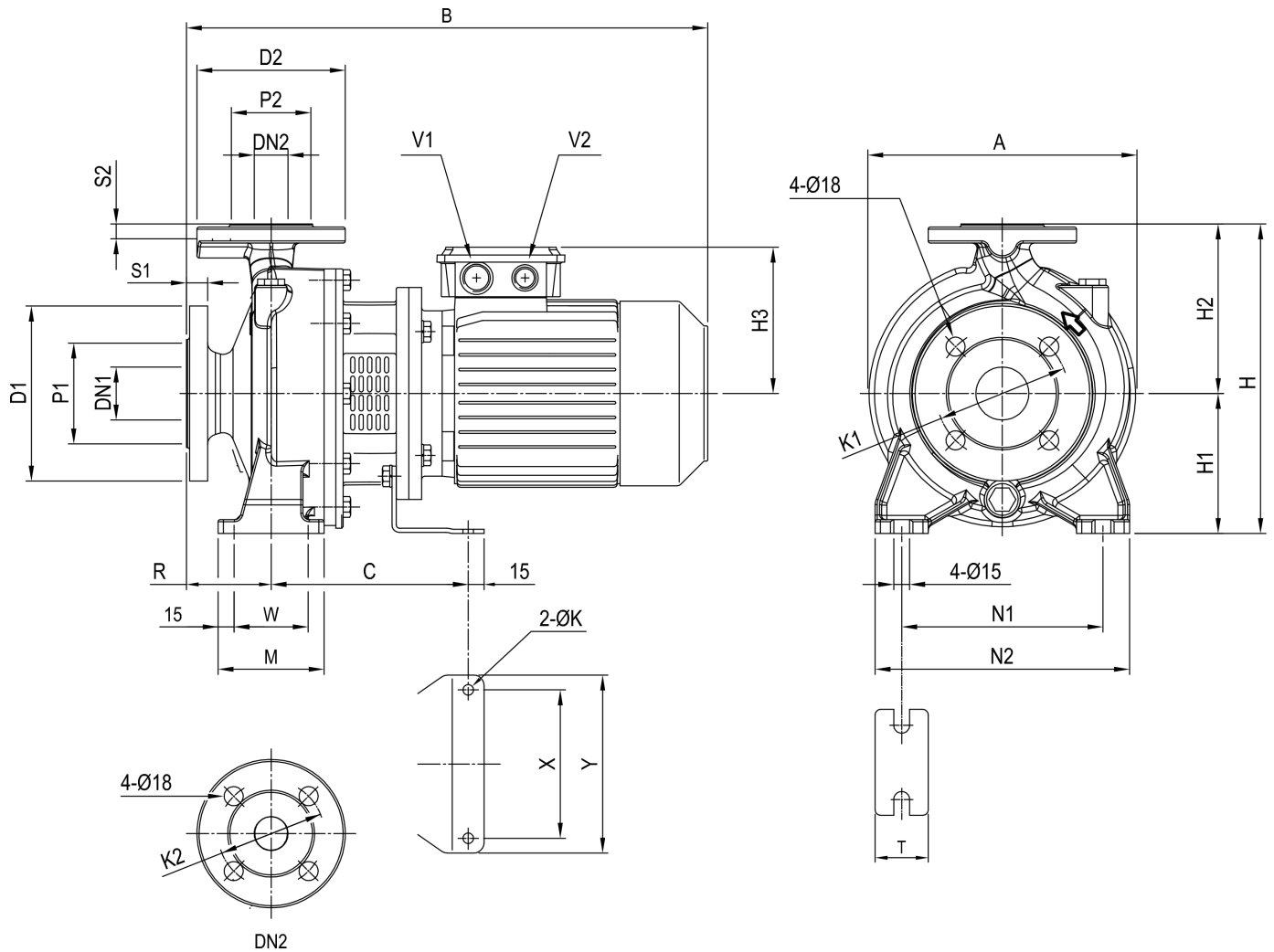

Dimensions in		mm		
1	A	296	K	10
2	B	497	M	125
3	C	186	N1	212
4	Dia D1	200	N2	280
5	Dia D2	185	R	100
6	Dia DN1	80	S1	22
7	Dia DN2	65	S2	20
8	Dia K1	160	T	65
9	Dia K2	145	V1	M25X1.5
10	Dia P1	138	V2	M20X1.5
11	Dia P2	122	W	95
12	H	360	Weight P&M	59.1 kg
13	H1	160	X	140
14	H2	200	Y	168
15	H3	148		

(1/3)

# Construction

Pump Name 3DS4 65-160/1.5

Customer	Date 09.06.2024	Company
Contact	Item no.	Issued by
Phone	Project	Phone
E-mail	Project ID	E-mail

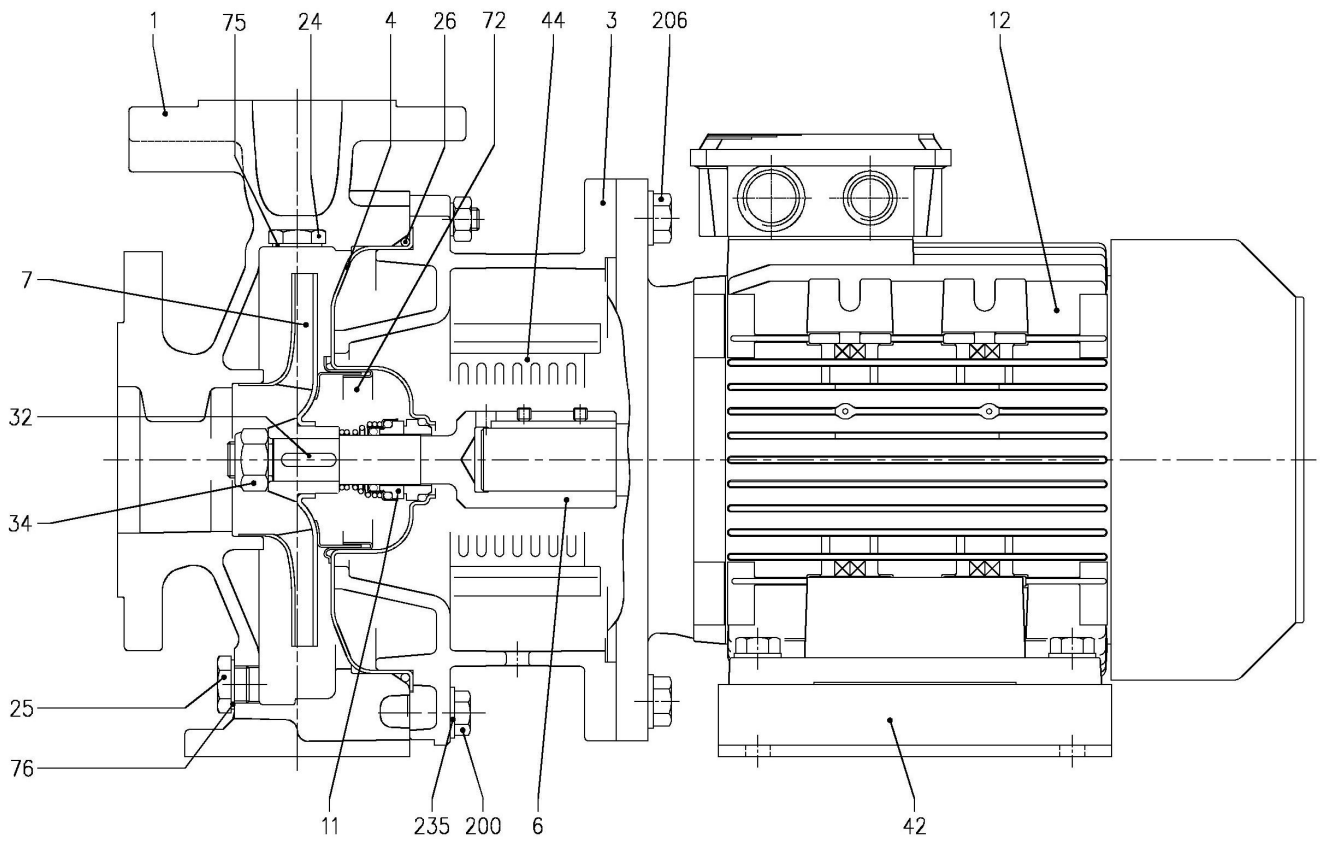

**(2/3)****Construction****Pump Name 3DS4 65-160/1.5**

Customer	Date 09.06.2024	Company
Contact	Item no.	Issued by
Phone	Project	Phone
E-mail	Project ID	E-mail

N°	PART NAME	MATERIAL	DIMENSIONS	STANDARD	Q.TY
001	Casing	Cast iron EN-GJL-200-EN 1561			1
003	Motor bracket	Cast iron EN-GJL-200-EN 1561			1
004	Casing cover	EN 1.4301 (AISI 304)			1
006	Coupling - Wet extensions	EN 1.4301 (AISI 304)			1
007	Impeller	[1]			1
011	Mechanical seal	[2]	[2]		1
012	Motor	-			1
024	Priming plug	Brass	G 3/8" L=8		1
025	Drain plug	Brass	G 3/8" L=8		1
026	"O" ring 32-12540-125 32-160, 40-160, 50-125, 65-125 32-200, 40-200, 50-160, 50-200, 65-160, 65-200	NBR [3]	158.11x5.34	OR 6625	1
			183.52x5.34	OR 6720	
			227.96x5.34	OR 6895	
032	Key	EN 1.4401 (AISI 316)	6x6x25	UNI 6604	1
034	Impeller nut Other models 50-200/2.2	EN 1.4301 (AISI 304)	M16x1.5	UNI 7474	1
			M18x1.5		
042	Foot	Galvanized Steel			1
044	Protection	EN 1.4301 (AISI 304)		EBARA DRAWING	1
072	Casing ring [4]	EN 1.4301 (AISI 304)			1
075	Washer	Aluminum	22x17x1.5	EBARA DRAWING	1
076	Washer	Aluminum			1
200	Screw 32-125 40-125 32-160 40-160 50-125 65-125 32-200, 40-200 50-160, 50-200 65-160, 65-200	Galvanized Steel 8.8 strength class ISO 898-1	M8x30	UNI 5739	8
			M10x35		10
					12
					12
			206		Screw for bracket up to 0.37 kW from 0.55 kW to 1.5 kW for 2.2 kW and 3 kW
235	Washer 32-125 40-125 32-160 40-160 50-125 65-125 32-200, 40-200 50-160, 50-200 65-160, 65-200	Galvanized Steel	8.4x17	UNI 6592	8
			10.5x21		10
					12
					12

[1] EN 1.4301 (AISI 304) for 32, 40, 50 series;  
EN 1.4401 (AISI 316) for 65 series

[2] See **CONSTRUCTION 3**

[3] FPM for H, HS, HW, HSW version;  
EPDM for E version

[4] Only for: 32-200, 40-200, 50-160, 50-200

(3/3)

# Construction

Pump Name 3DS4 65-160/1.5

Customer	Date 09.06.2024	Company
Contact	Item no.	Issued by
Phone	Project	Phone
E-mail	Project ID	E-mail

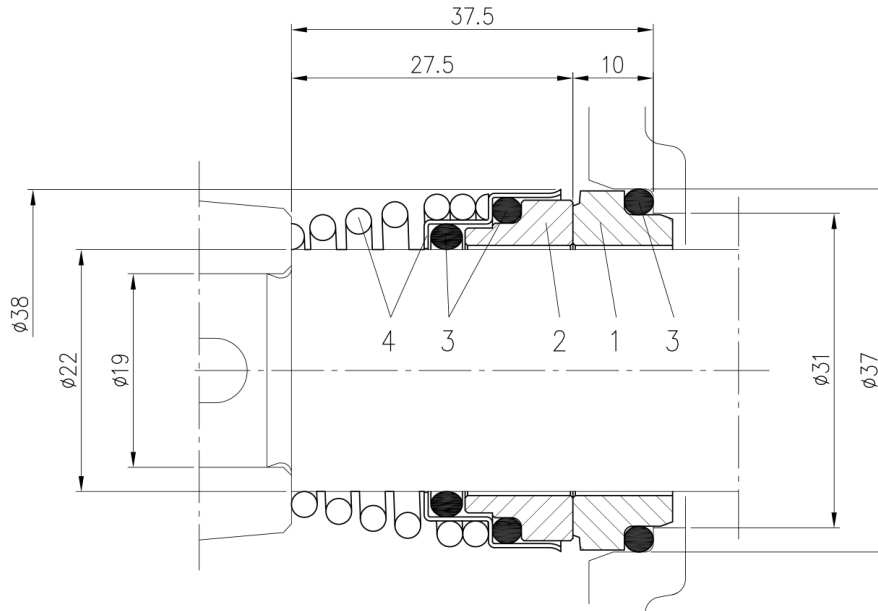

Version	Material			
	1 Stationary seal ring	2 Rotary seal ring	3 Rubber	4 Frame + Spring
Standard	Carbon	Ceramic	NBR	EN 1.4401 (AISI 316)