

# Technical Data

Pump Name

3DS 40-160/7.56

Customer	Date	2024-06-20	Company
Contact	Item no.		Issued by
Phone	Project		Phone
E-mail	Project ID	Proiect redenumit 2024-06-20 10:03:09	E-mail

## Requested data

1	Pump type	CENTRIFUGAL PUMPS	Fluid	Water
2	Number of pumps / Reserve	1 / 0	Liquid temperature	°C 20
3	Flow	m³/h	Kin. viscosity	mm²/s 1.005
4	Head	m	Vapour pressure	bar 0.0234
5	Geodetic head	m	PH value	
6	Inlet pressure (pin)	bar	Density	kg/m³ 998.3
7	Available system NPSH		Solids	Weight % 0
8	Ambient temperature	°C 20		

## Pump

9	Pump Name	3DS 40-160/7.56	Frequency	Hz	60
10	Design	CENTRIFUGAL PUMPS	Installation type		STANDARD
11	Manufacturer	EBARA	Impeller Diameter	Max.	mm 166
12	Speed	rpm 3480		Designed	mm 166
13	No. of Stage	1		Min.	mm 166
14	Connection	Suction side EN 1092-2	Flow	Operating	m³/h
15	Connection	Discharge side EN 1092-2		Max-	m³/h 50
16	Max Working Pressure	bar 10		Min-	m³/h 12
17	Shut-off head	bar 5.46	Head	Operating	m
18	Total weight	kg See the table of "Dimensions".		- (Qmax.)	m 38.5
19	Shaft power	kW		- (Qmin.)	m 54.0
20			Max. Shaft Power at max. impeller	kW	7.11
21	Required pump NPSH	m	Efficiency	%	

## Materials

22	Impeller	AISI 304		
23	Casing	Cast iron		
24	Shaft	AISI 304 (wet extension)		
25				
26				
27				

## Motor

28	Manufacturer	LAFERT	Insulation class	F
29	Type	TEFC_3DS 40-160/7.56_460_Three Phase	Phases	3~
30	Specific design	IE2 / 60 Hz / Pole pairs 1	Frame size	132 S
31	Rated power	kW 7.5	Weight	kg
32	Number of poles	2	Electric voltage	V 460
33	Speed	rpm 3500	Electric current	A 11.4
34	Degree of protection	IP 55		
35				

## Remarks

# Performance Curve

Pump Name

3DS 40-160/7.56

Customer	Date	2024-06-20	Company
Contact	Item no.		Issued by
Phone	Project		Phone
E-mail	Project ID	Project redenumit 2024-06-20 10:03:09	E-mail

**Requested data**

1	Flow	m³/h	
2	Head	m	
3	Geodetic head	m	

**Pump**

Operating flow	m³/h		Frequency	Hz	60
Operating head	m		Number of poles		2
Impeller diameter designed	mm	166	Speed	rpm	3480

Test standard: ISO 9906:2012 - Grade3B

Water; 20°C; 998.3kg/m³; 1mm²/s

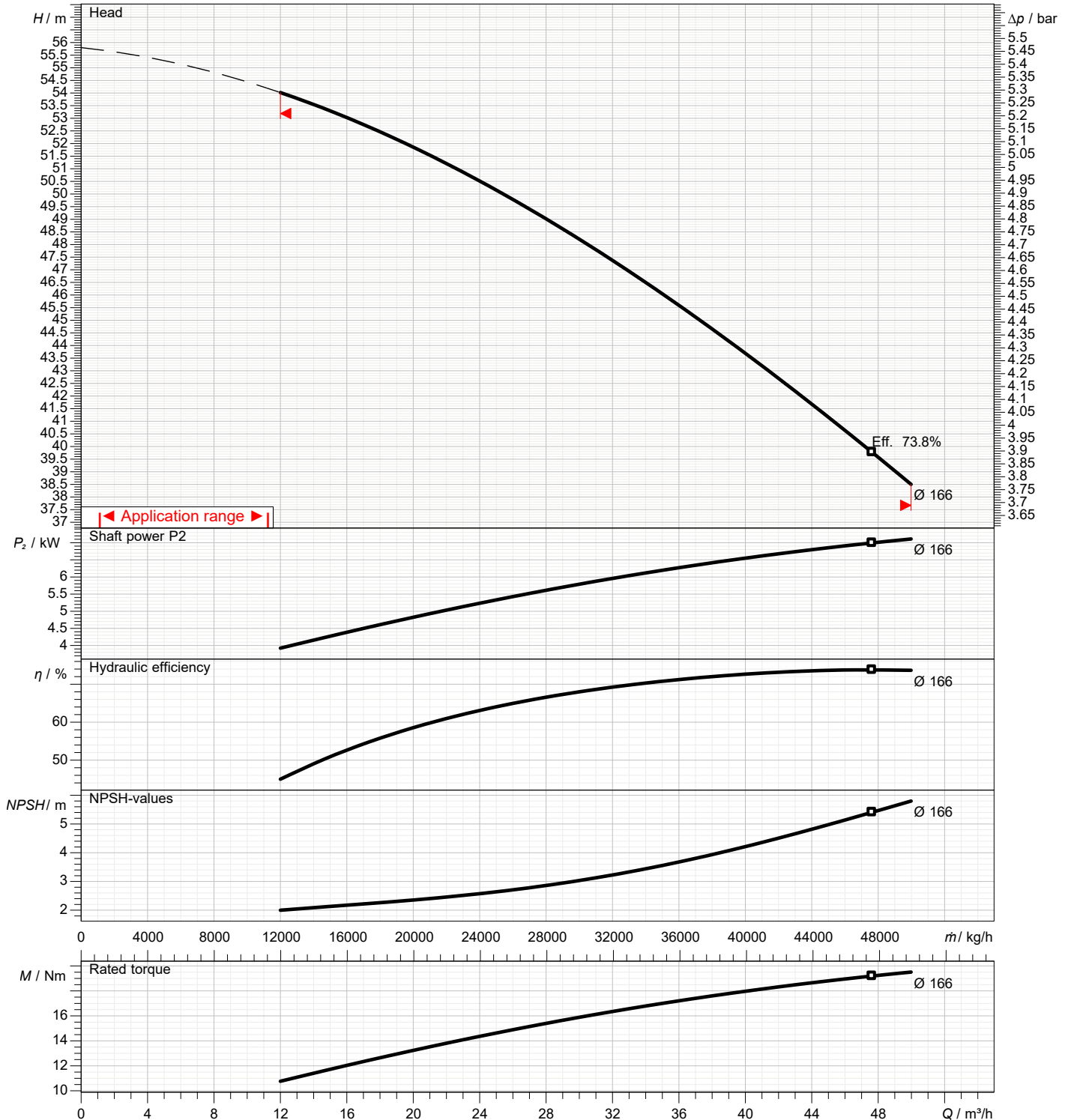

# Dimensions

Pump Name 3DS 40-160/7.56

Customer	Date 2024-06-20	Company
Contact	Item no.	Issued by
Phone	Project	Phone
E-mail	Project ID Proiect redenumit 2024-06-20 10:03:09	E-mail

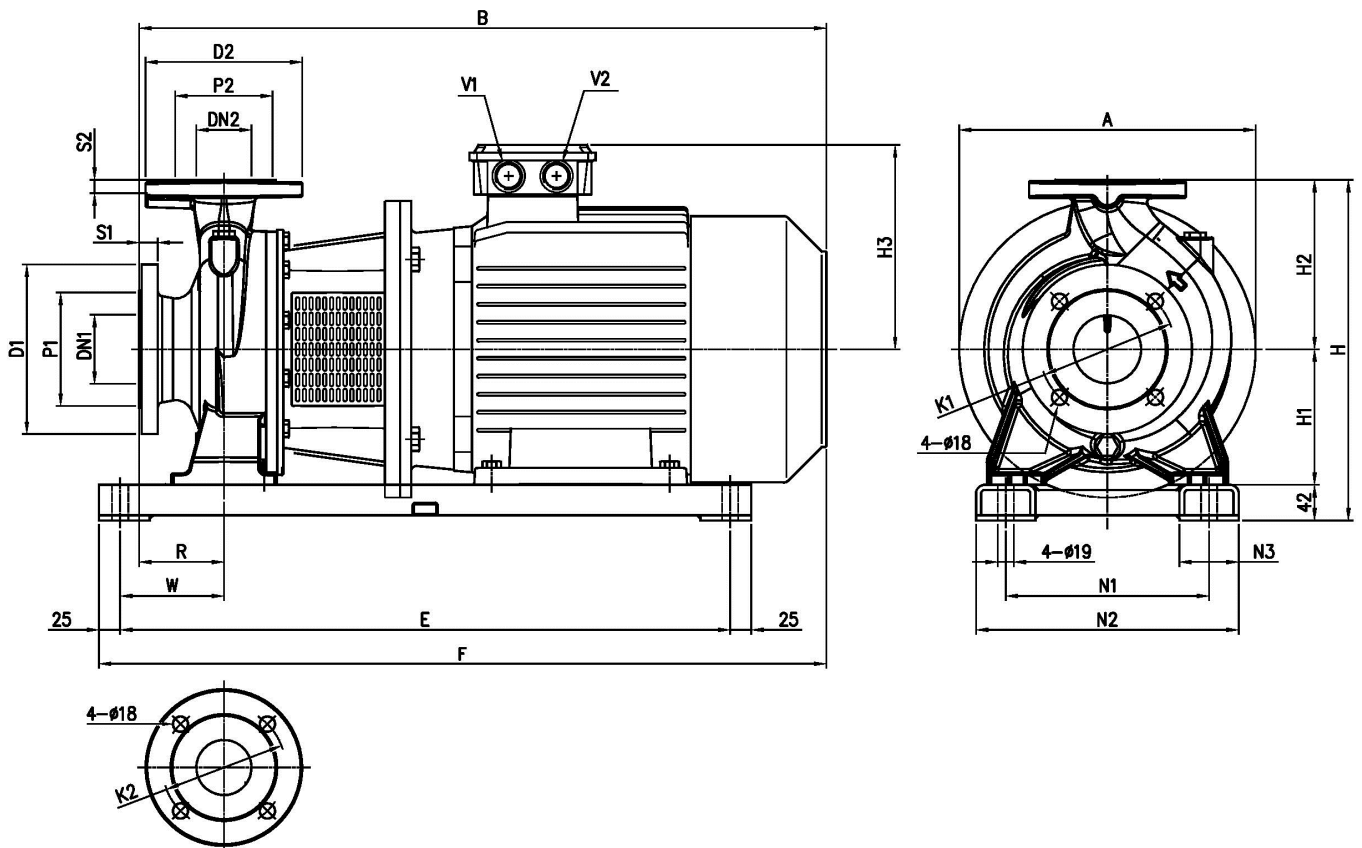

Dimensions in		mm					
1	A	300	H3	198			
2	B	607	N1	210			
3	Dia D1	185	N2	270			
4	Dia D2	150	N3	60			
5	Dia DN1	65	R	80			
6	Dia DN2	40	S1	20			
7	Dia K1	145	S2	18			
8	Dia K2	110	V1	M32x1.5			
9	Dia P1	122	V2	M32x1.5			
10	Dia P2	88	W	110			
11	E	600	Weight P&M	91 kg			
12	F	662					
13	H	334					
14	H1	132					
15	H2	160					

(1/3)

# Construction

Pump Name 3DS 40-160/7.56

Customer	Date 2024-06-20	Company
Contact	Item no.	Issued by
Phone	Project	Phone
E-mail	Project ID Proiect redenumit 2024-06-20 10:03:09	E-mail

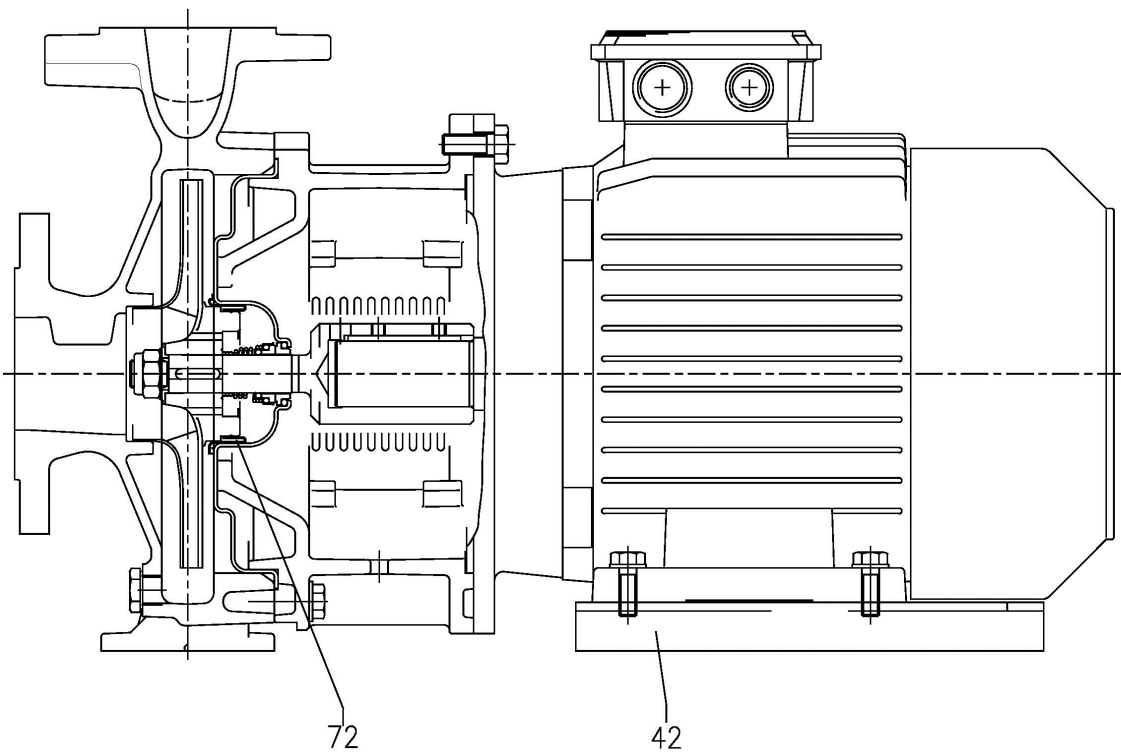
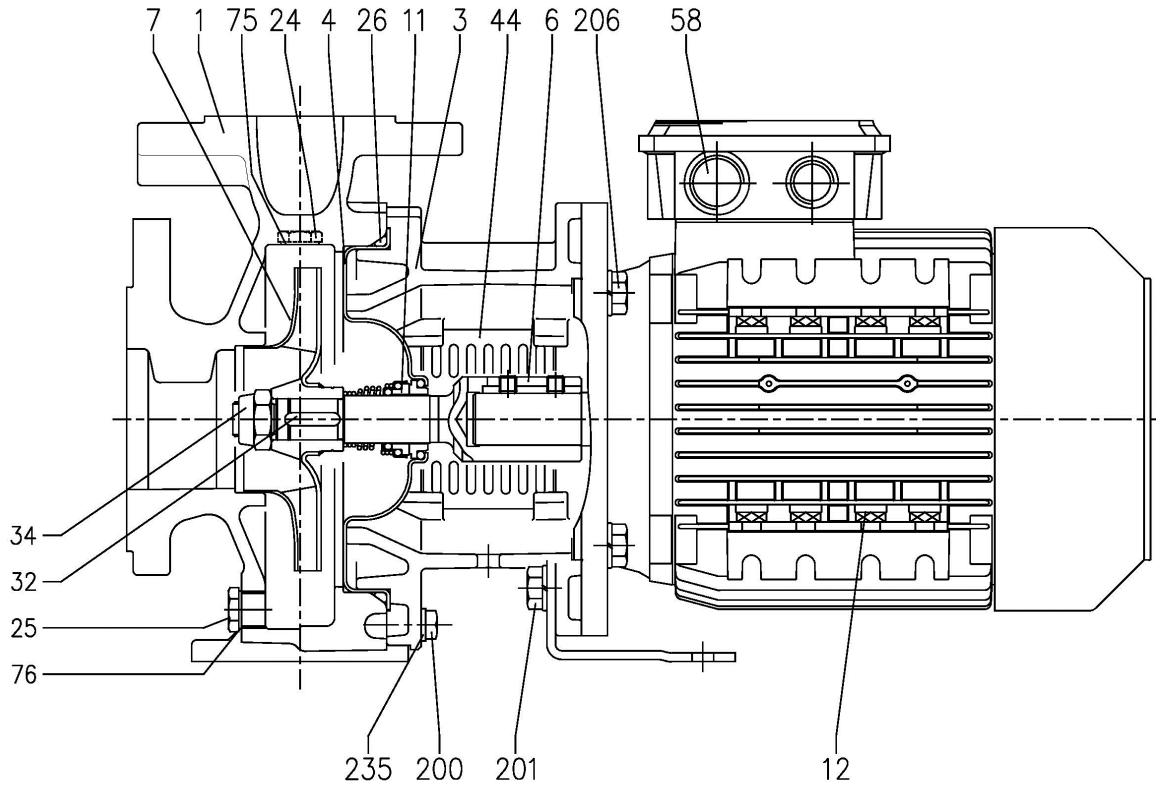

(2/3)

# Construction

Pump Name 3DS 40-160/7.56

Customer	Date	2024-06-20	Company
Contact	Item no.		Issued by
Phone	Project		Phone
E-mail	Project ID	Project redenumit 2024-06-20 10:03:09	E-mail

N°	PART NAME	MATERIAL	DIMENSIONS	STANDARD	Q.TY
1	Casing	Cast iron EN-GJL-200-EN 1561			1
3	Motor bracket	Cast iron EN-GJL-200-EN 1561			1
3A	Adapter ring	Cast iron EN-GJL-200-EN 1561			1
4	Casing cover	EN 1.4301 (AISI 304)			1
6	Coupling - Wet extensions	EN 1.4301 (AISI 304)			1
7	Impeller	EN 1.4301 (AISI 304)			1
11	Mechanical seal [1]	-	-		1
12	Motor	-			1
24	Priming plug	Brass	G 3/8" L=8		1
25	Draing plug	Brass	G 3/8" L=8		1
26	O-ring 32-125, 40-125 32-160, 40-160, 50-125 32-200, 40-200, 50-160 [2]	NBR/FPM/EPDM	158.11x5.34	OR 6625	1
			183.52x5.34	OR 6720	
			227.96x5.34	OR 6895	
32	Key Up to 11 Kw 15 kW and above	EN 1.4401 (AISI 316)	6x6x25 8x7x30	UNI 6604	1
34	Impeller nut Up to 11kW 15 kW and above	EN 1.4301 (AISI 304)	M16x1.5 M20x1.5	UNI 7474	1
42	Foot	Galvanized Steel			1
44	Protection	EN 1.4301 (AISI 304)		EBARA DRAWING	1
58	Cable gland	-			
72	Casing ring [3]	EN 1.4301 (AISI 304)			1
75	Washer	Aluminum	22x17x1.5	EBARA DRAWING	1
76	Washer	Aluminum			1
200	Screw 32-125, 40-125 32-160, 40-160, 50-125 32-200, 40-200, 50-160	Gv. Steel 8.8 strenght class ISO 898-1	M8x30	UNI 5739	8
			M10x35		10
					12
201	Screw [4]	Gv. Steel 8.8 strenght class ISO 898-1	M10x16	UNI 5739	2
206	Screw for bracket	Gv. Steel 8.8 strenght class ISO 898-1	M10x40	UNI 5739	4
206-2	Screw adapter ring	Gv. Steel 8.8 strenght class ISO 898-1	M12x20	UNI 5931	4
235	Washer 32-125, 40-125 32-160, 40-160, 50-125 32-200, 40-200, 50-160	Galvanized Steel	8.4x17	UNI 6592	8
			10.5x21		10
					12

[1] See **CONSTRUCTION 3**

[2] See **CONSTRUCTION 3**, "O-ring" column

[3] Only for: 32-200, 40-200, 50-160

[4] Only for version 32-125/1.16, 32-160/1.56, 32-160/2.26, 40-125/1.56, 40-125/2.26, 50-125/2.26

(3/3)

# Construction

Pump Name 3DS 40-160/7.56

Customer	Date 2024-06-20	Company
Contact	Item no.	Issued by
Phone	Project	Phone
E-mail	Project ID Proiect redenumit 2024-06-20 10:03:09	E-mail

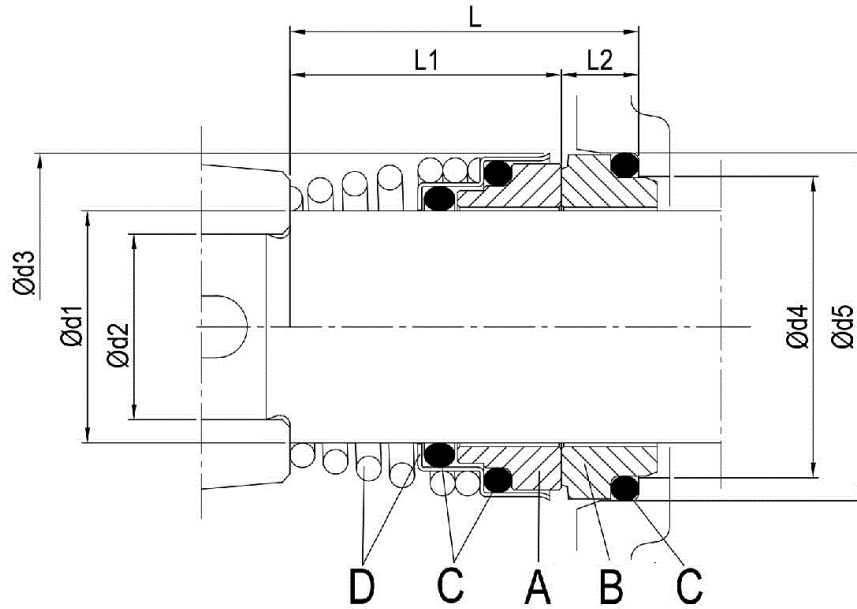

Pump type	Dimensions [ mm ]									Material Standard			
	d1	d2	d3	d4	d5	L	L1	L2	A Rotary seal ring	B Stationary seal ring	C O-ring	D Frame + Spring	
32-125/160/200 40-125/160/200 50-125/160 65-125 65-160/9.26-116	22	19	38	31	37	37.5	27.5	10	Ceramic	Carbon	NBR	EN 1.4301 (AISI 304)	