

# Technical Data

Pump Name

3DS 65-200/18.5

Customer	Date	09.06.2024	Company
Contact	Item no.		Issued by
Phone	Project		Phone
E-mail	Project ID		E-mail

## Requested data

1	Pump type	CENTRIFUGAL PUMPS	Fluid	Water	
2	Number of pumps / Reserve	1 / 0	Liquid temperature	°C	20
3	Flow	m³/h	Kin. viscosity	cSt	1.005
4	Head	m	Vapour pressure	kPa	2.34
5	Geodetic head	m	PH value		
6	Inlet pressure (pin)	kPa	Density	kg/m³	998.3
7	Available system NPSH		Solids	Weight %	0
8	Ambient temperature	°C	20		

## Pump

9	Pump Name	3DS 65-200/18.5	Frequency	Hz	50		
10	Design	CENTRIFUGAL PUMPS	Installation type		STANDARD		
11	Manufacturer	EBARA	Impeller Diameter	Max.	mm	201	
12	Speed	rpm		2900	Designed	mm	201
13	No. of Stage	1		Min.	mm	201	
14	Connection	Suction side	EN 1092-2	Flow	Operating	m³/h	
15	Connection	Discharge side	EN 1092-2		Max-	m³/h	138
16	Max Working Pressure	kPa	1000		Min-	m³/h	42
17	Shut-off head	kPa	587.62	Head	Operating	m	
18	Total weight	kg	See the table of "Dimensions".		- (Qmax.)	m	33.6
19	Shaft power	kW			- (Qmin.)	m	58.0
20				Max. Shaft Power at max. impeller	kW	18.05	
21	Required pump NPSH	m		Efficiency	%		

## Materials

22	Impeller	AISI 316		
23	Casing	Cast iron		
24	Shaft	AISI 304 (wet extension)		
25				
26				
27				

## Motor

28	Manufacturer	LAFERT	Insulation class	F		
29	Type	TEFC_3DS 65-200/18.5_400_Three Phase	Phases	3~		
30	Specific design	IE3 / 50 Hz / Pole pairs 1	Frame size	160 L		
31	Rated power	kW	18.5	Weight	kg	104
32	Number of poles	2	Electric voltage	V	400	
33	Speed	rpm	2900	Electric current	A	33
34	Degree of protection	IP 55				
35						

## Remarks

--

# Performance Curve

Pump Name

3DS 65-200/18.5

Customer	Date	09.06.2024	Company
Contact	Item no.		Issued by
Phone	Project		Phone
E-mail	Project ID		E-mail

## Requested data

1	Flow	m³/h	
2	Head	m	
3	Geodetic head	m	

## Pump

Operating flow	m³/h		Frequency	Hz	50
Operating head	m		Number of poles		2
Impeller diameter designed	mm	201	Speed	rpm	2900

Test standard: ISO 9906:2012 - Grade3B

Water; 20°C; 998.3kg/m³; 1cSt

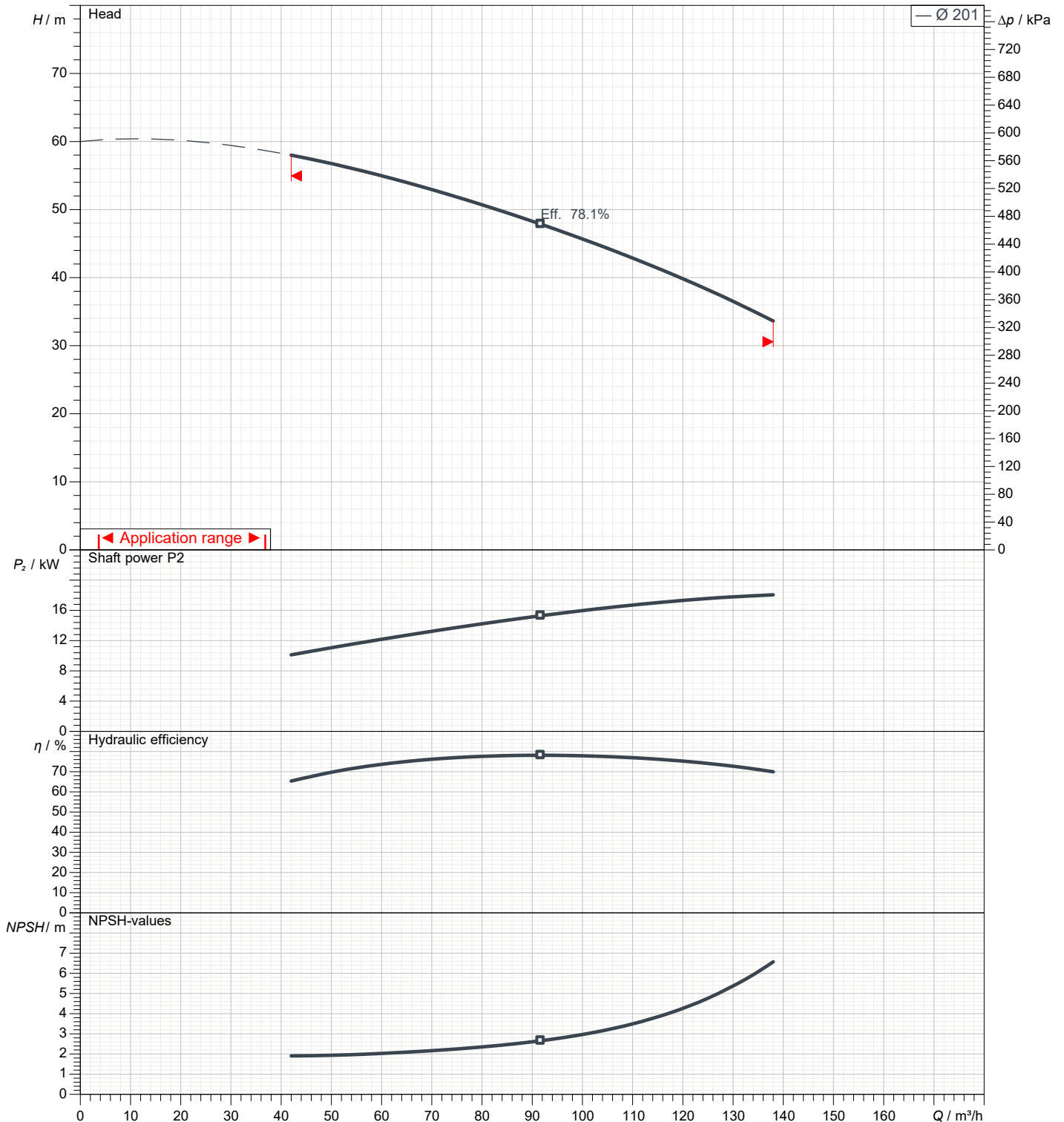

# Dimensions

Pump Name 3DS 65-200/18.5

Customer	Date 09.06.2024	Company
Contact	Item no.	Issued by
Phone	Project	Phone
E-mail	Project ID	E-mail

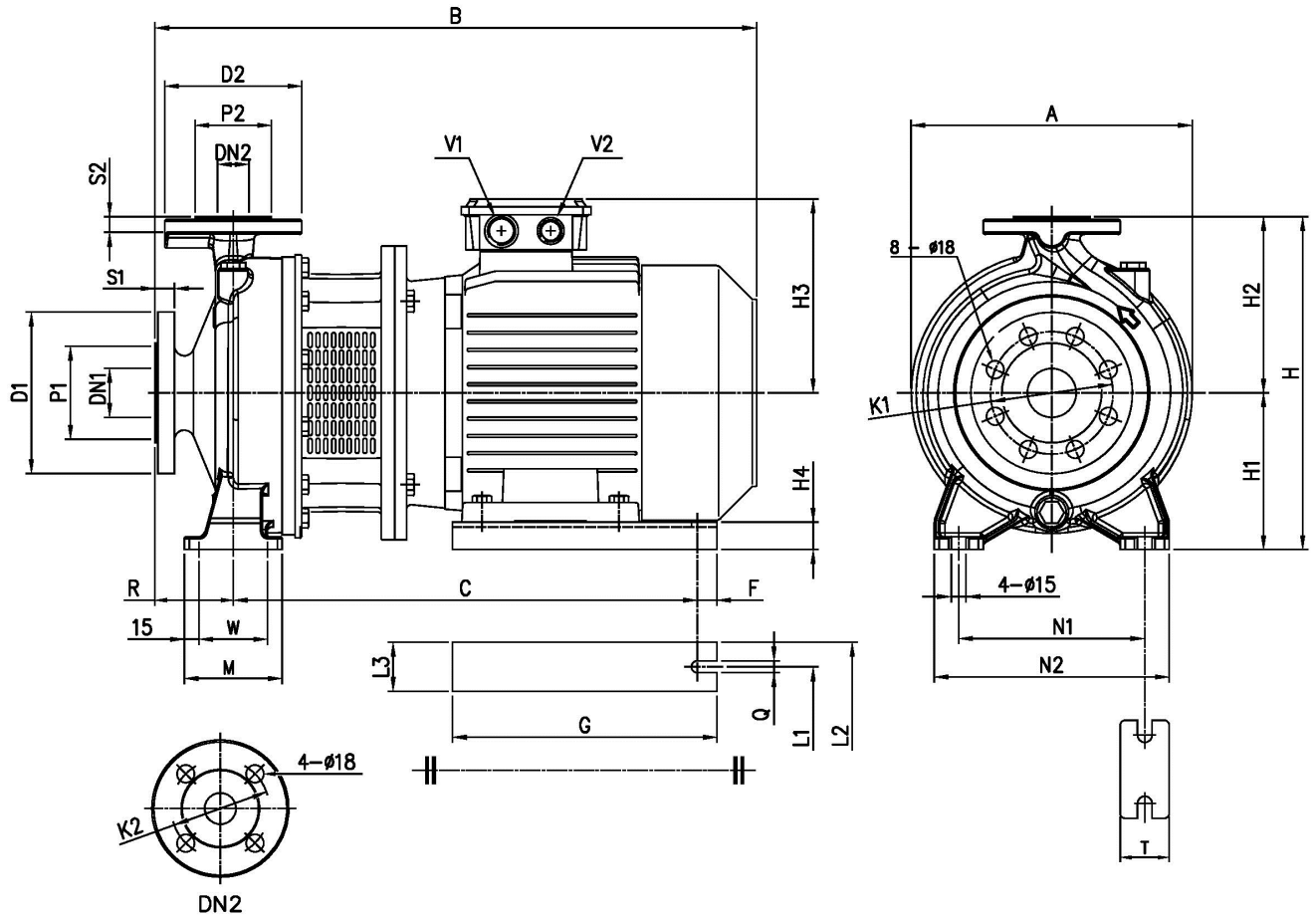

Dimensions in		mm					
1	A	312	H2	225	V2	M40x1,5	
2	B	850	H3	238	W	95	
3	C	621	H4	20	Weight P&M	158.5 kg	
4	Dia D1	200	L1	254			
5	Dia D2	185	L2	314			
6	Dia DN1	80	L3	60			
7	Dia DN2	65	M	125			
8	Dia K1	160	N1	250			
9	Dia K2	145	N2	320			
10	Dia P1	138	Q	14			
11	Dia P2	122	R	100			
12	F	20	S1	22			
13	G	350	S2	20			
14	H	405	T	65			
15	H1	180	V1	M40x1,5			

(1/3)

# Construction

Pump Name 3DS 65-200/18.5

Customer	Date 09.06.2024	Company
Contact	Item no.	Issued by
Phone	Project	Phone
E-mail	Project ID	E-mail

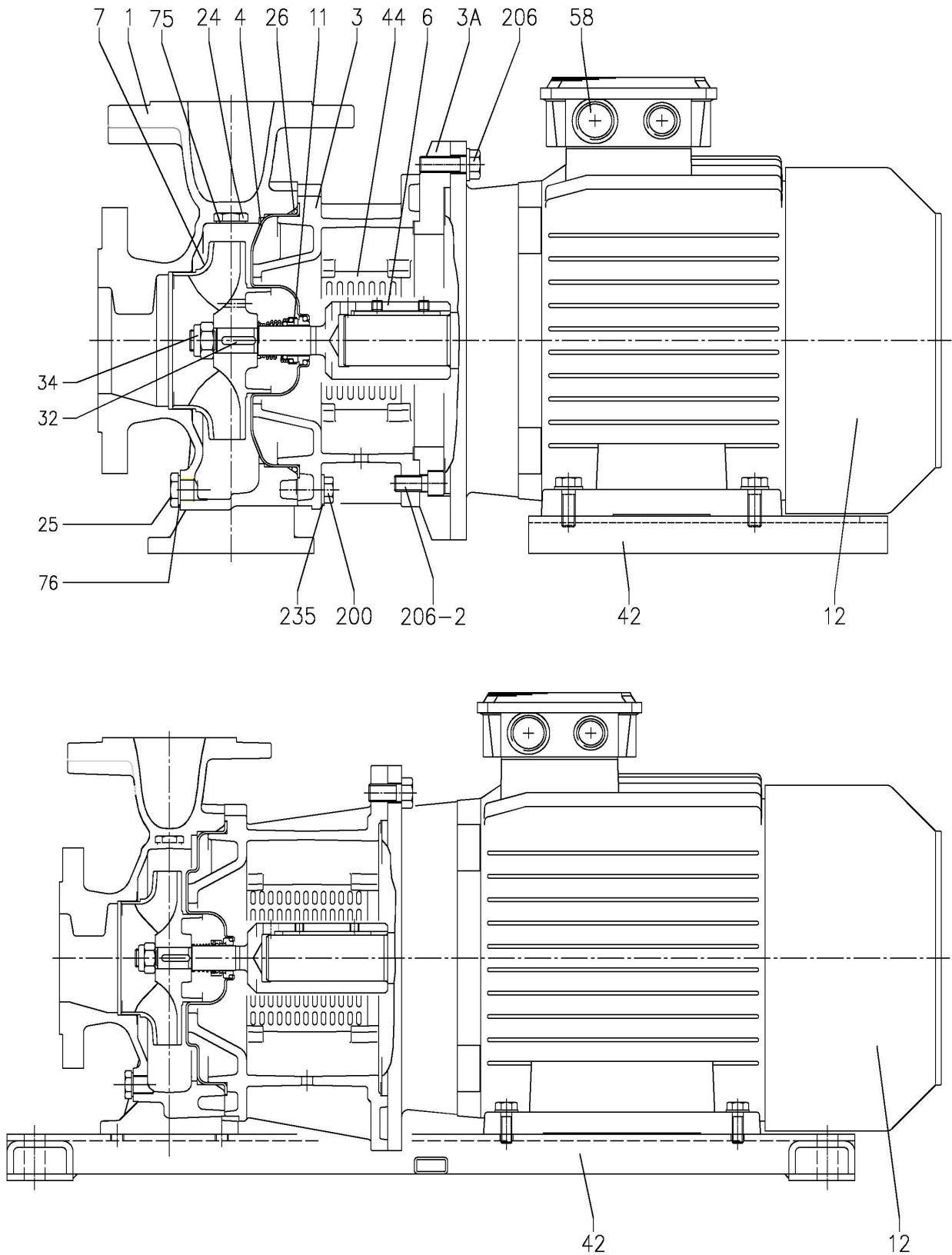

**(2/3)****Construction****Pump Name 3DS 65-200/18.5**

Customer	Date 09.06.2024	Company
Contact	Item no.	Issued by
Phone	Project	Phone
E-mail	Project ID	E-mail

N°	PART NAME	MATERIAL	DIMENSIONS	STANDARD	Q.TY
1	Casing	Cast iron EN-GJL-200-EN 1561			1
3	Motor bracket	Cast iron EN-GJL-200-EN 1561			1
3A	Adapter ring [1]	Cast iron EN-GJL-200-EN 1561			1
4	Casing cover	EN 1.4301 (AISI 304)			1
6	Coupling - Wet extensions	EN 1.4301 (AISI 304)			1
7	Impeller	EN 1.4401 (AISI 316)			1
11	Mechanical seal [2]	-			1
12	Motor	-			1
24	Priming plug	Brass	G 3/8" L=8		1
25	Draing plug	Brass	G 3/8" L=8		1
26	O-ring <u>65-125</u> <u>65-160, 65-200</u> [3]	NBR/FPM/EPDM	183.52x5.34	OR 6720	1
32	Key <u>Up to 11 kW</u> <u>15 kW and above</u>	EN 1.4401 (AISI 316)	6x6x25 8x7x30	UNI 6604	1
34	Impeller nut <u>Up to 11 kW</u> <u>15 kW and above</u>	EN 1.4301 (AISI 304)	M16x1.5 M20x1.5	UNI 7474	1
42	Foot	Galvanized Steel			[4]
44	Protection	EN 1.4301 (AISI 304)		EBARA DRAWING	1
58	Cable gland	-			
72	Casing ring	EN 1.4301 (AISI 304)			1
75	Washer	Aluminum	22x17x1.5	EBARA DRAWING	1
76	Washer	Aluminum			1
200	Screw <u>65-125</u> <u>65-160, 65-200</u>	Gv. Steel 8.8 strenght class ISO 898-1	M10x35	UNI 5739	10 12
201	Screw	Gv. Steel 8.8 strenght class ISO 898-1	M10x16	UNI 5739	2
206	Screw for bracket	Gv. Steel 8.8 strenght class ISO 898-1	M10x40	UNI 5739	4
206-2	Screw adapter ring [1]	Gv. Steel 8.8 strenght class ISO 898-1	M12x20	UNI 5931	4
235	Washer <u>65-125</u> <u>65-160, 65-200</u>	Galvanized Steel	10.5x21	UNI 6592	10 12

[1] Only for 65-125/5.5 and 65-125/7.5

[2] See **CONSTRUCTION 3**

[3] See **CONSTRUCTION 3**, "O-ring" column

[4] 0 for version 65-200/22

1 for version for 65-125/5.5, 65-125/7.5, 65-160/11, 65-160/15, 65-200/15, 65-200/18.5

2 for version for 65-125/4, 65-160/7.5, 65-160/9.2

(3/3)

# Construction

Pump Name 3DS 65-200/18.5

Customer	Date 09.06.2024	Company
Contact	Item no.	Issued by
Phone	Project	Phone
E-mail	Project ID	E-mail

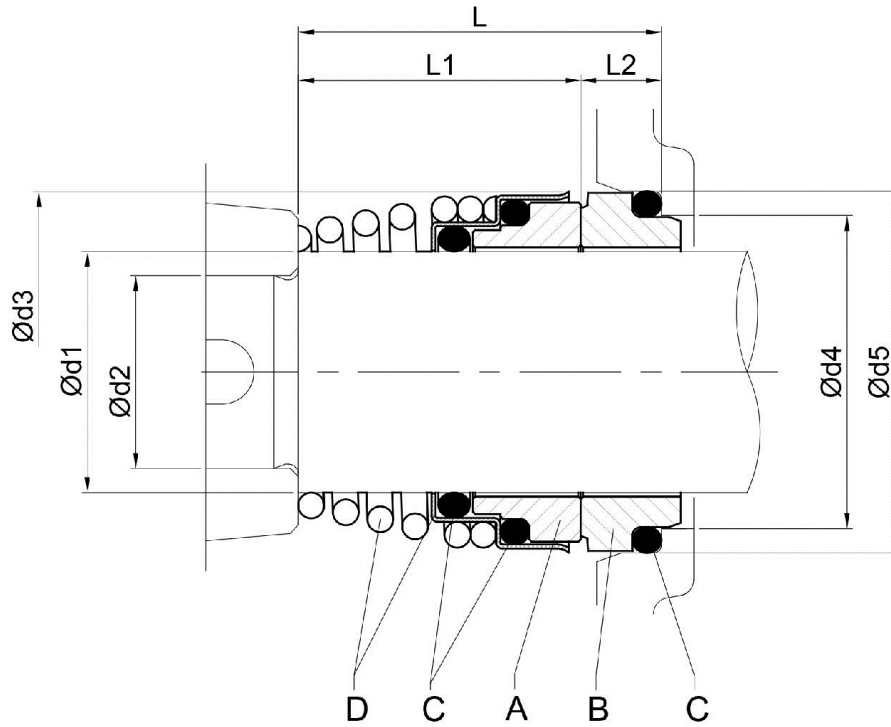

Pump type	Dimensions [ mm ]								Material Standard			
	d1	d2	d3	d4	d5	L	L1	L2	A Rotary seal ring	B Stationary seal ring	C O-ring	D Frame + Spring
65-160/15 65-200	30	24	46	39	45	42.5	32.5	10	Ceramic	Carbon	NBR	EN 1.4401 (AISI 316)