

# Technical Data

Pump Name

3D 32-125/1.1

Customer	Date	09.06.2024	Company
Contact	Item no.		Issued by
Phone	Project		Phone
E-mail	Project ID		E-mail

## Requested data

1	Pump type	CENTRIFUGAL PUMPS	Fluid	Water
2	Number of pumps / Reserve	1 / 0	Liquid temperature	°C 20
3	Flow m³/h		Kin. viscosity	cSt 1.005
4	Head m		Vapour pressure	kPa 2.34
5	Geodetic head m		PH value	
6	Inlet pressure (pin) kPa	0	Density	kg/m³ 998.3
7	Available system NPSH		Solids	Weight % 0
8	Ambient temperature °C	20		

## Pump

9	Pump Name	3D 32-125/1.1	Frequency	Hz 50
10	Design	CENTRIFUGAL PUMPS	Installation type	STANDARD
11	Manufacturer	EBARA	Impeller Diameter	Max. mm 133
12	Speed rpm	2900		Designed mm 133
13	No. of Stage	1		Min. mm 133
14	Connection Suction side	EN 1092-2	Flow	Operating m³/h
15	Connection Discharge side	EN 1092-2		Max- m³/h 20
16	Max Working Pressure kPa	1000		Min- m³/h 6
17	Shut-off head kPa	225.24	Head	Operating m
18	Total weight kg	See the table of "Dimensions".		- (Qmax.) m 12.5
19	Shaft power kW			- (Qmin.) m 22.4
20			Max. Shaft Power at max. impeller	kW 1.12
21	Required pump NPSH m		Efficiency	%

## Materials

22	Impeller	AISI 304	
23	Casing	Cast iron	
24	Shaft	AISI 304 (wet extension)	
25			
26			
27			

## Motor

28	Manufacturer	EPE Standard	Insulation class	F
29	Type	TEFC_3D 32-125/1.1M_230_Single Phase	Phases	1~
30	Specific design	IE2 / 50 Hz / Pole pairs 1	Frame size	
31	Rated power kW	1.1	Weight	kg
32	Number of poles	2	Electric voltage	V 230
33	Speed rpm	2900	Electric current	A 6.7
34	Degree of protection	IP 55		
35				

## Remarks

# Performance Curve

Pump Name

3D 32-125/1.1

Customer	Date 09.06.2024	Company
Contact	Item no.	Issued by
Phone	Project	Phone
E-mail	Project ID	E-mail

## Requested data

1	Flow	m³/h	
2	Head	m	
3	Geodetic head	m	

## Pump

Operating flow	m³/h	Frequency	Hz	50	
Operating head	m	Number of poles		2	
Impeller diameter designed	mm	133	Speed	rpm	2900

Test standard: ISO 9906:2012 - Grade3B

Water; 20°C; 998.3kg/m³; 1cSt

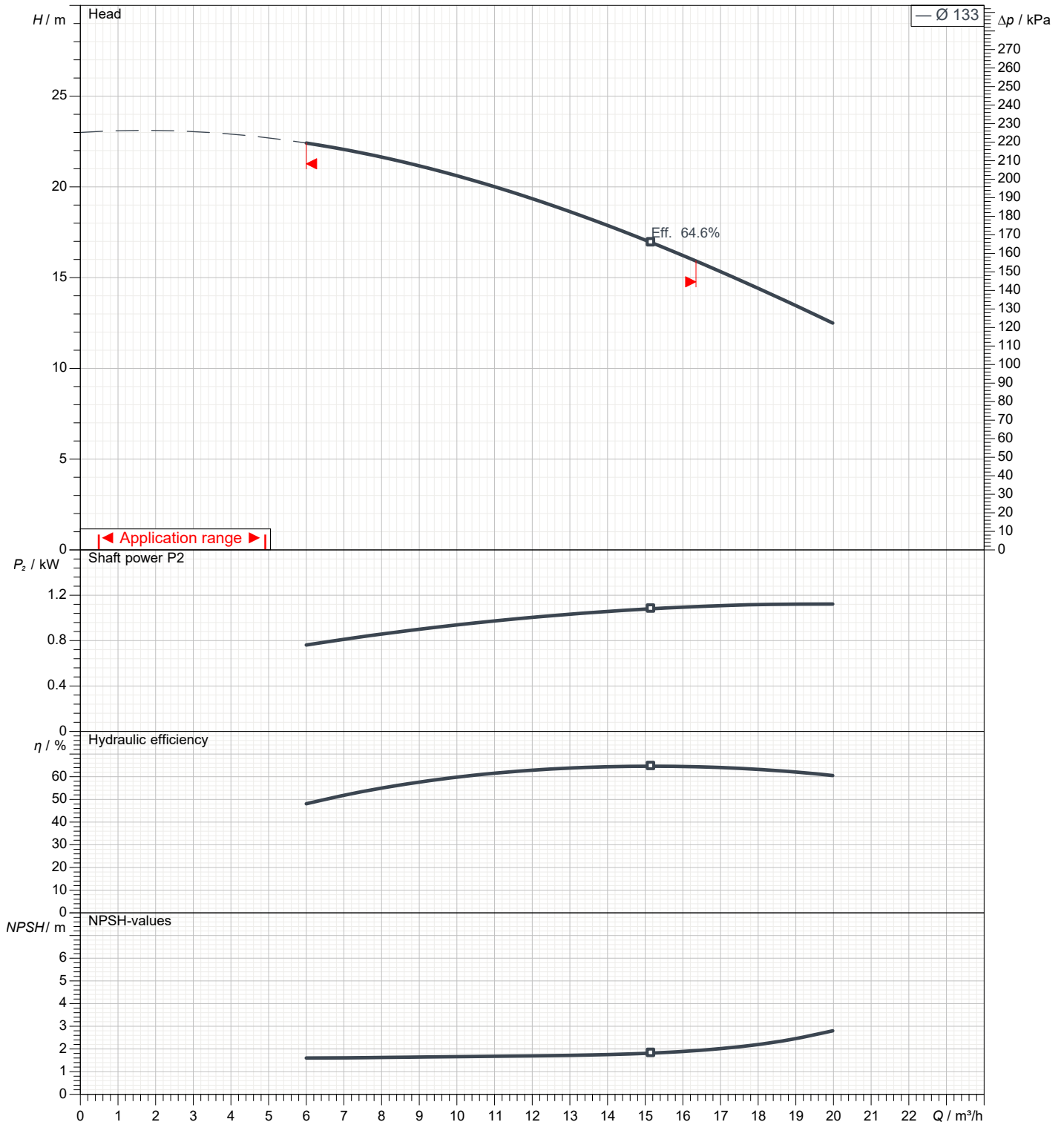

# Dimensions

Pump Name 3D 32-125/1.1

Customer	Date 09.06.2024	Company
Contact	Item no.	Issued by
Phone	Project	Phone
E-mail	Project ID	E-mail

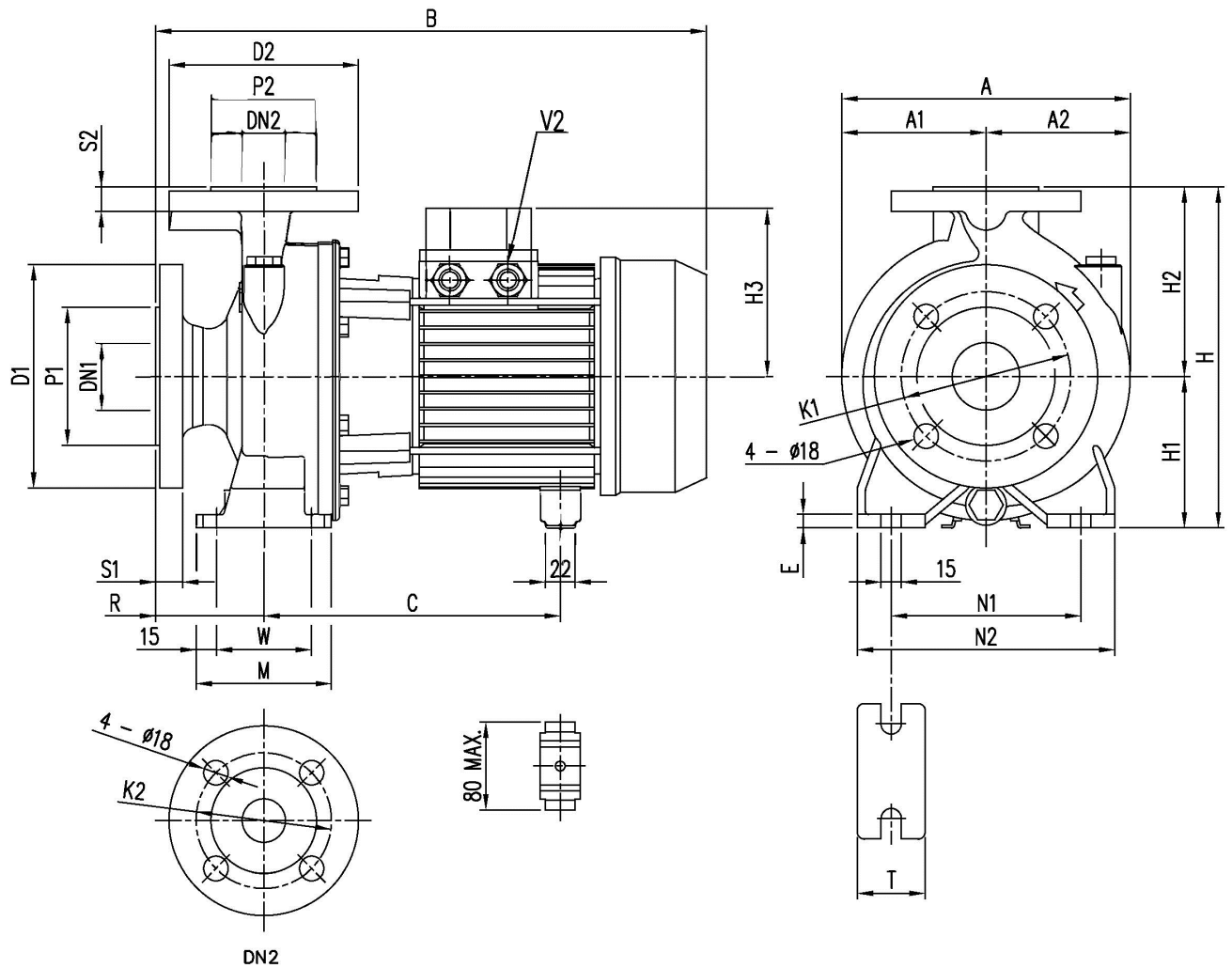

Dimensions in		mm		
1	A	213	H1	112
2	A1	106.5	H2	140
3	A2	106.5	H3	119
4	B	431	M	100
5	C	232	N1	140
6	Dia D1	165	N2	190
7	Dia D2	140	R	80
8	Dia DN1	50	S1	20
9	Dia DN2	32	S2	18
10	Dia K1	125	T	50
11	Dia K2	100	V2	M16X1,5
12	Dia P1	102	W	70
13	Dia P2	78	Weight P&M	29.5 kg
14	E	10		
15	H	252		

(1/3)

# Construction

Pump Name 3D 32-125/1.1

Customer	Date 09.06.2024	Company
Contact	Item no.	Issued by
Phone	Project	Phone
E-mail	Project ID	E-mail

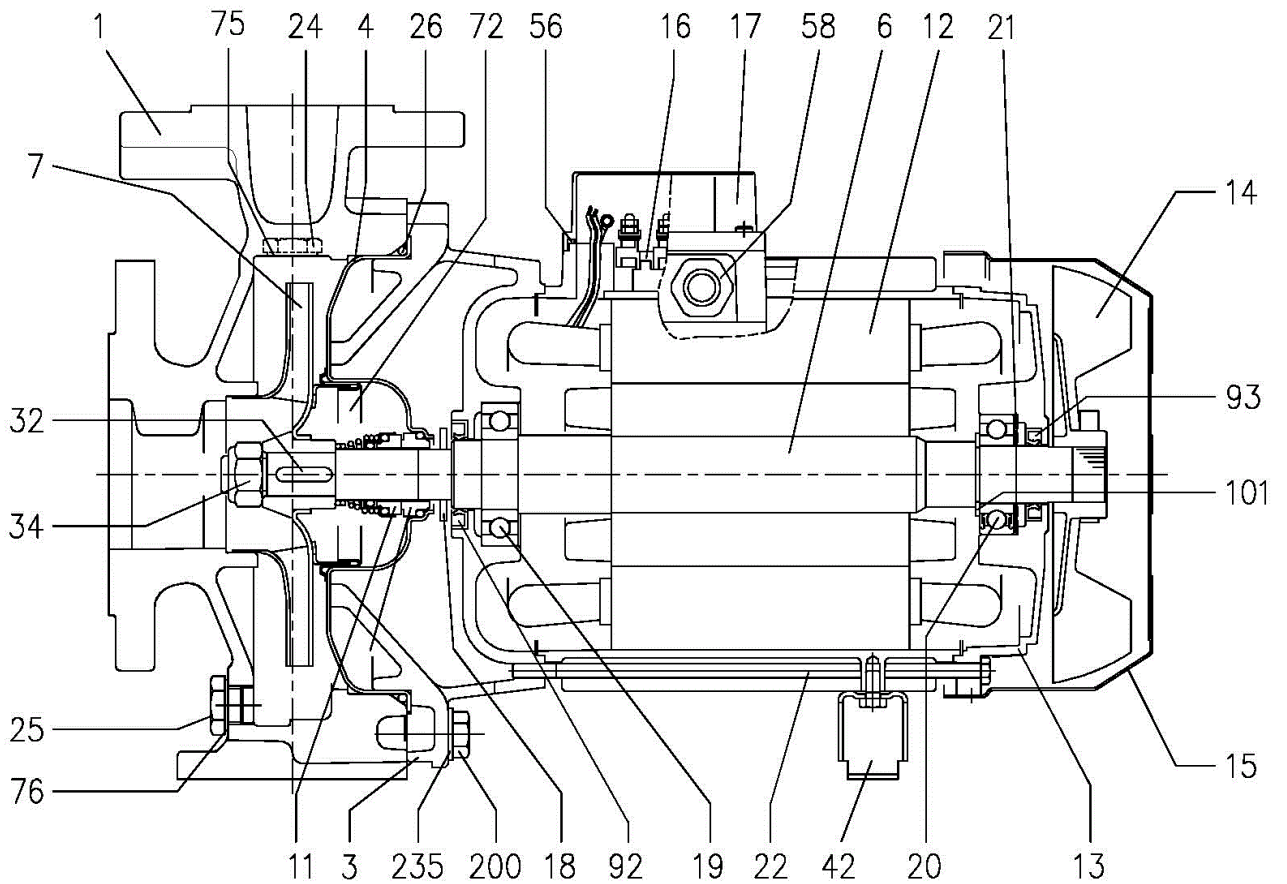

**(2/3)****Construction****Pump Name 3D 32-125/1.1**

Customer	Date 09.06.2024	Company
Contact	Item no.	Issued by
Phone	Project	Phone
E-mail	Project ID	E-mail

N°	PART NAME	MATERIAL	DIMENSIONS	STANDARD	Q.TY
1	Casing	Cast iron EN-GJL-250-EN 1561			1
3	Motor bracket [1]	-			1
4	Casing cover	EN 1.4301 (AISI 304)			1
6	Shaft with rotor - Wet extension	EN 1.4301 (AISI 304)			1
7	Impeller [2]	-			1
11	Mechanical seal [3]	-			1
12	Motor frame with stator	-			1
13	Motor cover	Aluminium			1
14	Fan	PA			1
15	Fan cover	Fe P04 Galvanized			1
16	Terminal	-			1
17	Terminal box cover	Aluminium (three phase version)			1
18	Splash ring Up to 11 kW	NBR	40x21.5x2	EBARA DRAWING	1
19	Bearing [10]	-			1
20	Bearing [10]	-			1
21	Adjusting ring	Steel C70			1
22	Tie rod	Fe 42 Galvanized	Up to 3 kW M5	EBARA DRAWING	4
	For 4 - 5.5 - 7.5 kW M6				
	9.2 e 11 kW M8				
24	Priming plug	Brass	G 3/8" L=8		1
25	Draing plug	Brass	G 3/8" L=8		1
26	O-ring	NBR/FPM/EPDM	32-125, 40-125 158.11x5.34	OR 6625	1
	32-160, 40-160, 50-125, 65-125 183.52x5.34		OR 6720		
	32-200, 40-200, 50-160, 50-200/9.2, 50-200/11, 227.96x5.34		OR 6895		
	65-160/7.5, 65-160/9.2, 65-160/11				
32	Key Up to 11 kW	EN 1.4401 (AISI 316)	A 6x6x25	UNI 6604	1
34	Impeller nut Up to 11 kW	EN 1.4301 (AISI 304)	M16x1.5	UNI 7474	1
42	Foot	Aluminium / Galvanized steel		EBARA DRAWING	1
56	Box gasket	NBR			1
58	Cable gland	-			1
72	Casing ring	EN 1.4301 (AISI 304)			1
75	Washer	Aluminium			1
76	Washer	Aluminium	22x17x1.5	EBARA DRAWING	1
92	Lip seal	-	Up to 3 kW 25x40x7	DIN 3760 without spring	1
	From 4 to 7.5 kW 30x47X7				
	From 9.2 kW to 11 kW 40x55x7				
93	Lip seal	-	Up to 4 kW 25x40x7	DIN 3760 without spring	1
	From 5.5 kW to 7.5 kW 30x47X7				
	From 9.2 kW to 11 kW 40x55x7				
101	Snap ring [6]	Carbon tool steels TC 80	Ø 40	UNI 7435	1
200	Screw	Gv. Steel 8.8 strenght class ISO 898-1	32-125, 40-125 M 8x30	UNI 5739	8
	32-160, 40-160, 50-125, 65-125 M 10x35		10		
	32-200, 40-200, 50-160, 50-200/9.2, 50-200/11, 65-160/7.5, 65-160/9.2, 65-160/11		12		
235	Washer	Galvanized Steel	32-125, 40-125 8.4x17	UNI 6592	8
	32-160, 40-160, 50-125, 65-125 10.5x21		10		
	32-200, 40-200, 50-160, 50-200/9.2, 50-200/11, 65-160/7.5, 65-160/9.2, 65-160/11		12		

- [1] Cast iron EN-GJL-200-EN 1561 for 3D 32-200/3  
Aluminum AL-EN-1706-AC-46000-D for all the others
- [2] EN 1.4301 (AISI 304) for 32, 40, 50 series  
EN 1.4401 (AISI 316) for 65 series
- [3] See **CONSTRUCTION 3**
- [4] See **CONSTRUCTION 3**, "O-ring" column
- [5] Only for: 32-200, 40-200, 50-160, 50-200/9.2, 50-200/11
- [6] Only for pumps with 9.2 and 11 kW motor

(3/3)

# Construction

Pump Name 3D 32-125/1.1

Customer	Date 09.06.2024	Company
Contact	Item no.	Issued by
Phone	Project	Phone
E-mail	Project ID	E-mail

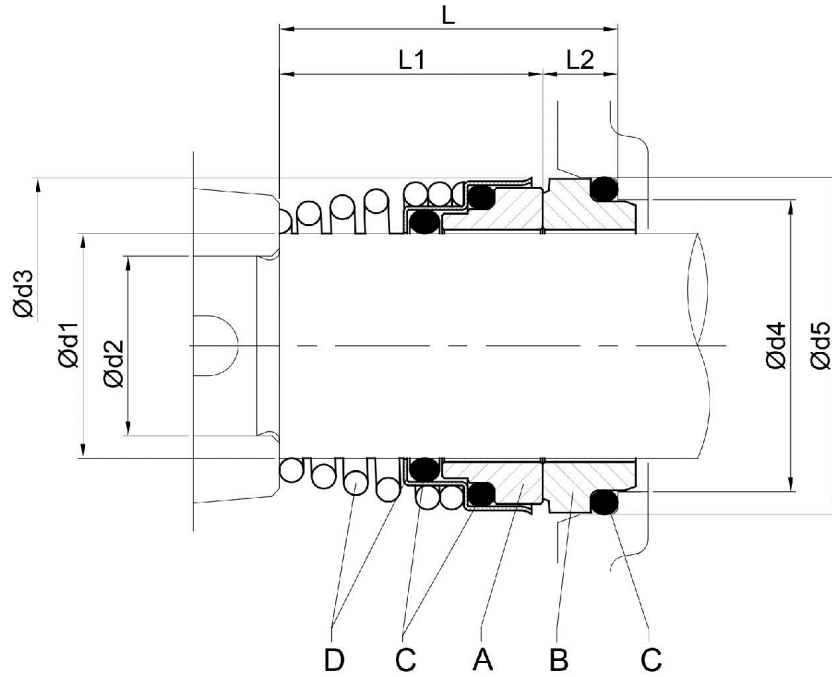

Pump type	Dimensions [ mm ]								Material Standard			
	d1	d2	d3	d4	d5	L	L1	L2	A Rotary seal ring	B Stationary seal ring	C O-ring	D Frame + Spring
32-125/160/200												
40-125/160/200												
50-125/160/200	22	19	38	31	37	37.5	27.5	10	Ceramic	Carbon	NBR	EN 1.4301 (AISI 304)
65-125												
65-160/7.5-9.2-11												