

Technical Data

Pump Name

3D 40-160/5.56

Customer	Date	2024-06-20	Company
Contact	Item no.		Issued by
Phone	Project		Phone
E-mail	Project ID	Proiect redenumit 2024-06-20 10:03:09	E-mail

Requested data

1	Pump type	CENTRIFUGAL PUMPS	Fluid	Water
2	Number of pumps / Reserve	1 / 0	Liquid temperature	°C
3	Flow	m³/h	Kin. viscosity	mm²/s
4	Head	m	Vapour pressure	bar
5	Geodetic head	m	PH value	
6	Inlet pressure (pin)	bar	Density	kg/m³
7	Available system NPSH		Solids	Weight %
8	Ambient temperature	°C		

Pump

9	Pump Name	3D 40-160/5.56	Frequency	Hz	60	
10	Design	CENTRIFUGAL PUMPS	Installation type		STANDARD	
11	Manufacturer	EBARA	Impeller Diameter	Max.	mm	
12	Speed	rpm		3480	Designed	mm
13	No. of Stage	1		Min.	mm	151
14	Connection	Suction side	EN 1092-2	Flow	Operating	m³/h
15	Connection	Discharge side	EN 1092-2		Max-	m³/h
16	Max Working Pressure	bar	10		Min-	m³/h
17	Shut-off head	bar	4.37	Head	Operating	m
18	Total weight	kg	See the table of "Dimensions".		- (Qmax.)	m
19	Shaft power	kW			- (Qmin.)	m
20			Max. Shaft Power at max. impeller	kW	5.04	
21	Required pump NPSH	m	Efficiency	%		

Materials

22	Impeller	AISI 304		
23	Casing	Cast iron		
24	Shaft	AISI 304 (wet extension)		
25				
26				
27				

Motor

28	Manufacturer	EPE Standard	Insulation class	F	
29	Type	TEFC_3D 40-160/5.56_380_Three Phase	Phases	3~	
30	Specific design	IE3 / 60 Hz / Pole pairs 1	Frame size		
31	Rated power	kW	5.5	Weight	kg
32	Number of poles	2	Electric voltage	V	380
33	Speed	rpm	3500	Electric current	A
34	Degree of protection	IP 55			
35					

Remarks

Performance Curve

Pump Name

3D 40-160/5.56

Customer	Date	2024-06-20	Company
Contact	Item no.		Issued by
Phone	Project		Phone
E-mail	Project ID	Proiect redenumit 2024-06-20 10:03:09	E-mail

Requested data

1	Flow	m³/h	
2	Head	m	
3	Geodetic head	m	

Pump

Operating flow	m³/h		Frequency	Hz	60
Operating head	m		Number of poles		2
Impeller diameter designed	mm	151	Speed	rpm	3480

Test standard: ISO 9906:2012 - Grade3B

Water; 20°C; 998.3kg/m³; 1mm²/s

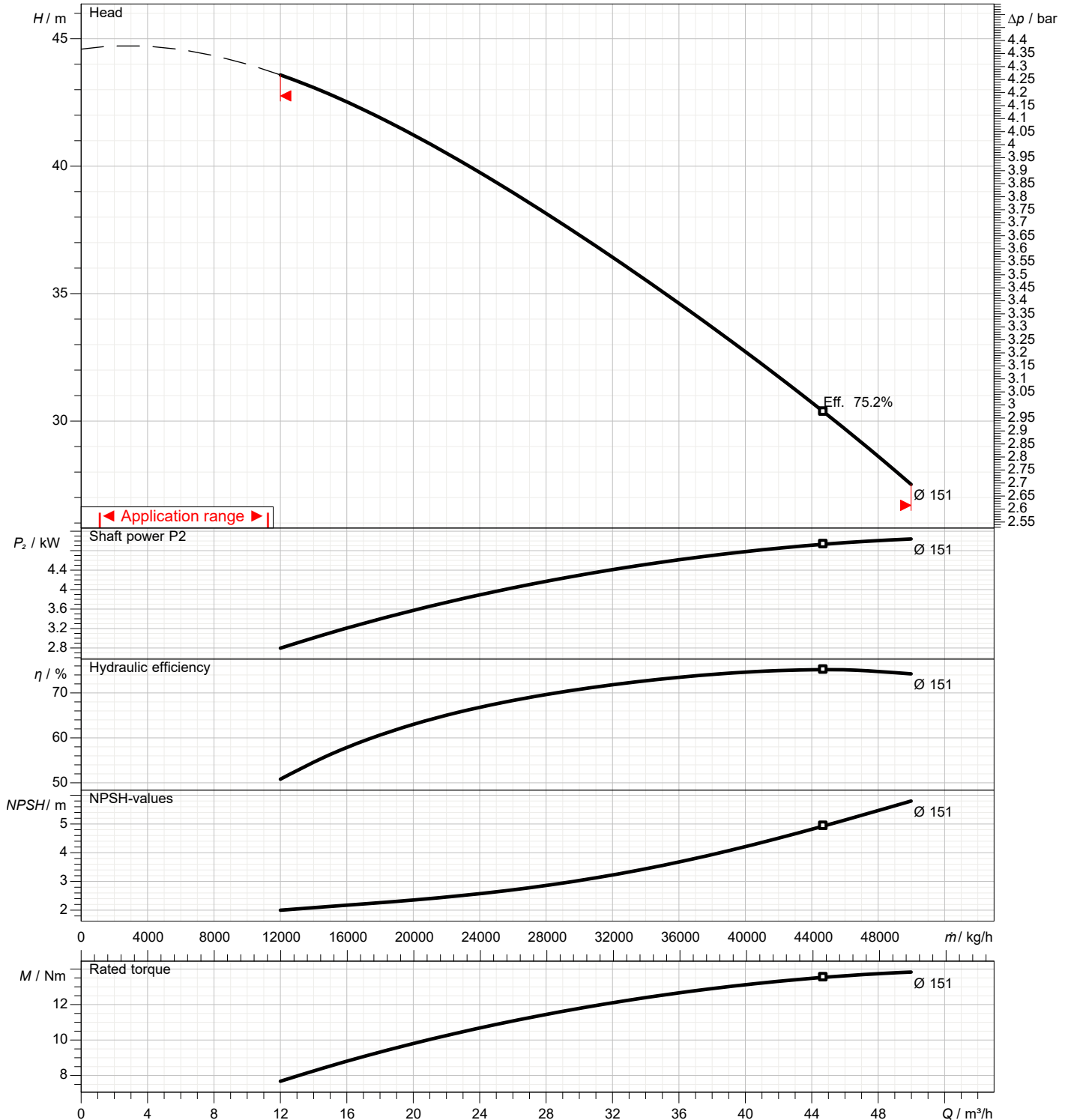

Dimensions

Pump Name 3D 40-160/5.56

Customer	Date 2024-06-20	Company
Contact	Item no.	Issued by
Phone	Project	Phone
E-mail	Project ID Proiect redenumit 2024-06-20 10:03:09	E-mail

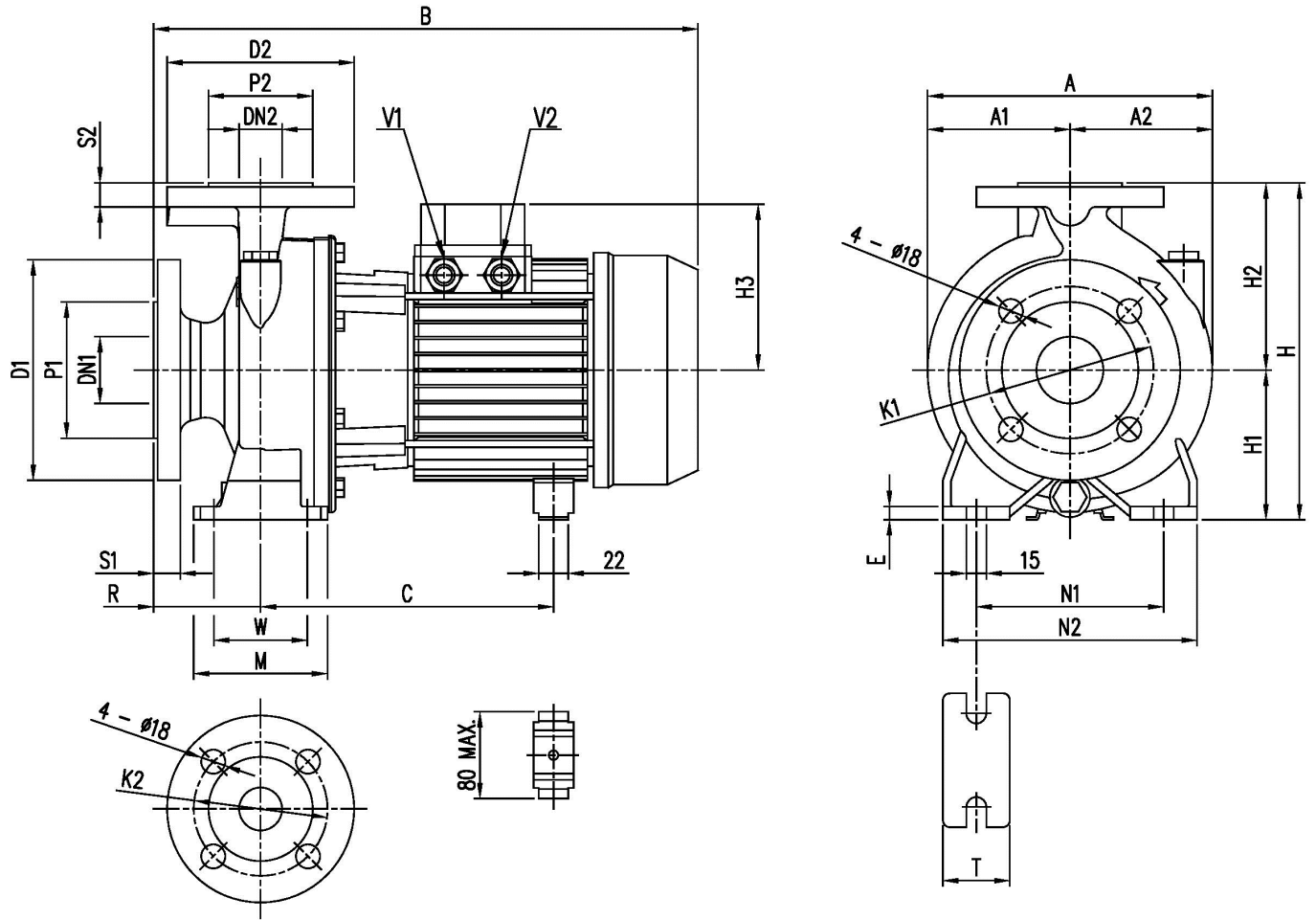

Dimensions in		mm		
1	A	254	H1	132
2	A1	127	H2	160
3	A2	127	H3	150
4	B	519	M	100
5	C	275	N1	190
6	Dia D1	185	N2	240
7	Dia D2	150	R	80
8	Dia DN1	65	S1	20
9	Dia DN2	40	S2	18
10	Dia K1	145	T	50
11	Dia K2	110	V1	[PG 13].5
12	Dia P1	122	V2	M25x1.5
13	Dia P2	88	W	70
14	E	12	Weight P&M	54,3 kg
15	H	292		

(1/3) Construction

Pump Name 3D 40-160/5.56

Customer	Date 2024-06-20	Company
Contact	Item no.	Issued by
Phone	Project	Phone
E-mail	Project ID Proiect redenumit 2024-06-20 10:03:09	E-mail

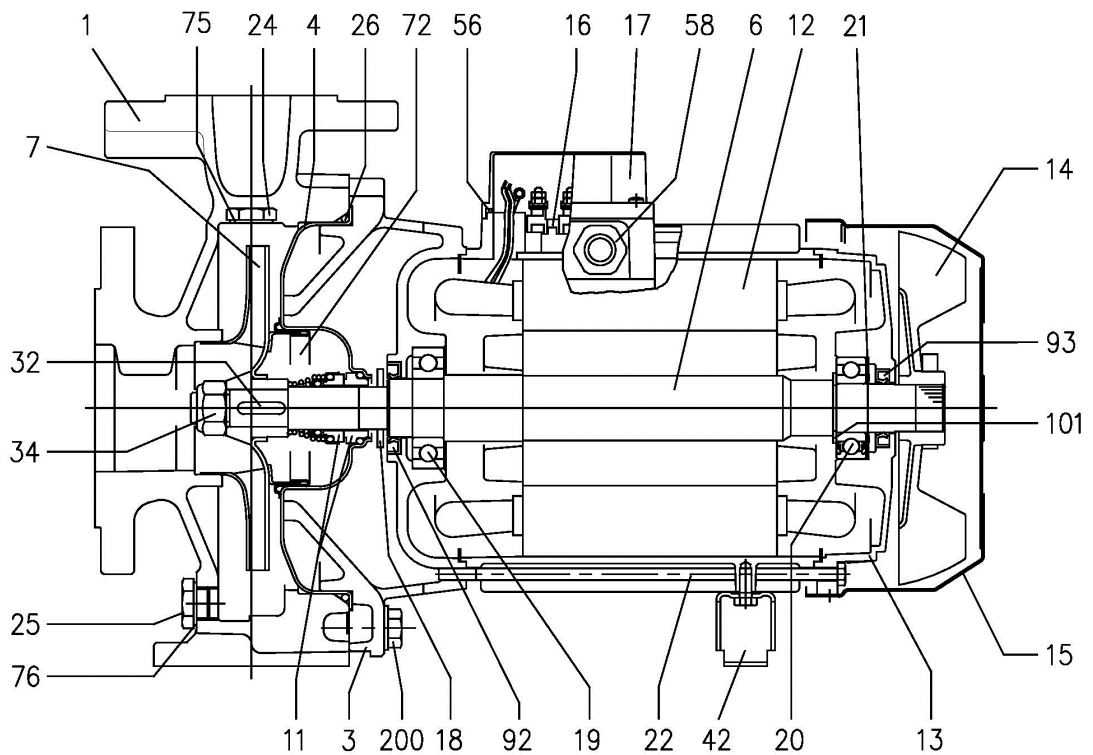

(2/3)

Construction

Pump Name 3D 40-160/5.56

Customer	Date 2024-06-20	Company
Contact	Item no.	Issued by
Phone	Project	Phone
E-mail	Project ID Proiect redenumit 2024-06-20 10:03:09	E-mail

N°	PART NAME	MATERIAL	DIMENSIONS	STANDARD	Q.TY
1	Casing	Cast iron EN-GJL-250-EN 1561			1
3	Motor bracket [1]	-			1
4	Casing cover	EN 1.4301 (AISI 304)			1
6	Shaft with rotor - Wet extension	EN 1.4301 (AISI 304)			1
7	Impeller [2]	-			1
11	Mechanical seal [3]	-			1
12	Motor frame with stator	-			1
13	Motor cover	Aluminium			1
14	Fan	PA			1
15	Fan cover	Fe P04 Galvanized			1
16	Terminal	-			1
17	Terminal box cover	Aluminium (three phase version)			1
18	Splash ring Up to 11 kW	NBR	40x21.5x2	EBARA DRAWING	1
19	Bearing	-			1
20	Bearing	-			1
21	Adjusting ring	Steel C70			1
22	Tie rod Up to 3 kW For 4 - 5.5 - 7.5 kW 9.2 e 11kW	Fe 42 Galvanized	M5 M6 M8	EBARA DRAWING	4
24	Priming plug	Brass	G 3/8" L=8		1
25	Draining plug	Brass	G 3/8" L=8		1
26	O-ring 32-125, 40-125 32-160, 40-160, 50-125, 65-125 32-200, 40-200/9.26, 50-160/9.26, 65-160/9.26	NBR/FPM/EPDM	158.11x5.34 183.52x5.34 227.96x5.34	OR 6625 OR 6720 OR 6895	1
32	Key Up to 3 kW	EN 1.4401 (AISI 316)	A 6x6x25	UNI 6604	1
34	Impeller nut Up to 11kW	EN 1.4301 (AISI 304)	M16x1.5	UNI 7474	1
42	Foot	Aluminium / Galvanized steel		EBARA DRAWING	1
56	Box gasket	NBR			1
58	Cable gland	-			1
72	Casing ring [5]	EN 1.4301 (AISI 304)			1
75	Washer	Aluminum	22x17x1.5	EBARA DRAWING	1
76	Washer	Aluminum			1
92	Lip seal Up to 3kW From 4 to 7.5 kW From 9.2 kW to 11 kW	-	25x40x7 30x47x7 40x55x7	DIN 3760 without spring	1
93	Lip seal Up to 4 kW From 5.5 kW to 7.5 kW From 9.2 kW to 11 kW	-	25x40x7 30x47x7 40x55x7	DIN 3760 without spring	1
101	Snap ring [6]	Carbon tool steels TC 80	Ø 40	UNI 7435	1
200	Screw 32-125, 40-125 32-160, 40-160, 50-125, 65-125 32-200, 40-200/9.26, 50-160/9.26, 65-160/9.26	Gv. Steel 8.8 strenght class ISO 898-1	M 8x30 M 10x35	UNI 5739	8 10 12
235	Washer 32-125, 40-125 32-160, 40-160, 50-125, 65-125 32-200, 40-200/9.26, 50-160/9.26, 65-160/9.26	Galvanized Steel	8.4x17 10.5x21	UNI 6592	8 10 12

[1] Cast iron EN-GJL-200-EN 1561 for 3D 40-125/4.6, 40-160/7.56, 65-125/5.56; 65-125/7.56

Aluminum AL-EN-1706-AC-46000-D for all the others

[2] EN 1.4301 (AISI 304) for 32, 40, 50 series

EN 1.4401 (AISI 316) for 65 series

[3] See **CONSTRUCTION 3**

[4] See **CONSTRUCTION 3**, "O-ring" column

[5] Only for: 32-200, 40-200, 50-160

[6] Only for pumps with 9.2 and 11 kW motor

(3/3)

Construction

Pump Name 3D 40-160/5.56

Customer	Date 2024-06-20	Company
Contact	Item no.	Issued by
Phone	Project	Phone
E-mail	Project ID Proiect redenumit 2024-06-20 10:03:09	E-mail

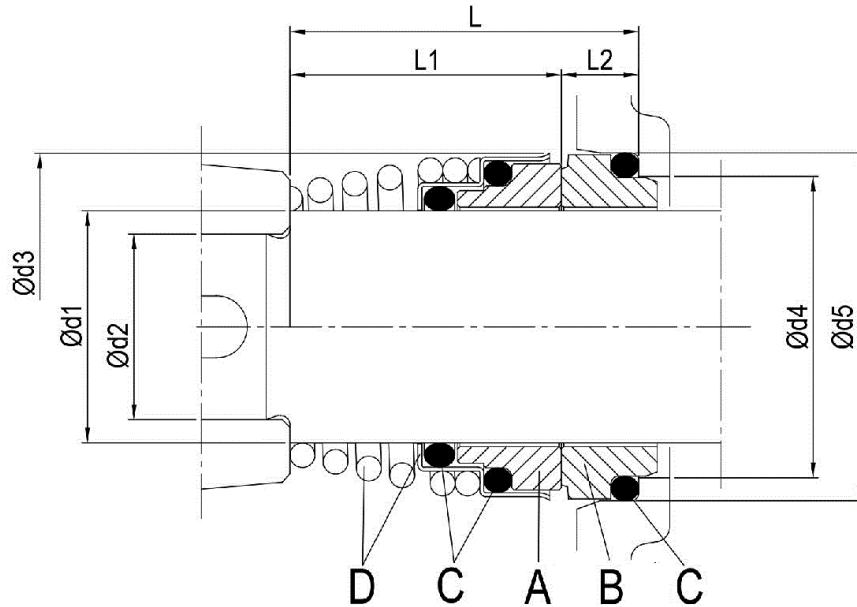

Pump type	Dimensions [mm]									Material Standard			
	d1	d2	d3	d4	d5	L	L1	L2	A Rotary seal ring	B Stationary seal ring	C O-ring	D Frame + Spring	
32-125/160/200 40-125/160/200 50-125/160 65-125 65-160/9.26-116	22	19	38	31	37	37.5	27.5	10	Ceramic	Carbon	NBR	EN 1.4301 (AISI 304)	