

Technical Data

Pump Name

3E-K4 100-160/2.2Q4Q1EGG TT

Customer	Date	09.06.2024	Company
Contact	Item no.		Issued by
Phone	Project		Phone
E-mail	Project ID		E-mail

Requested data

1	Pump type	IN-LINE CENTRIFUGAL PUMP	Fluid	Water
2	Number of pumps / Reserve	1 / 0	Liquid temperature	°C
3	Flow	m³/h	Kin. viscosity	cSt
4	Head	m	Vapour pressure	kPa
5	Geodetic head	m	PH value	
6	Inlet pressure (pin)	kPa	Density	kg/m³
7	Available system NPSH		Solids	Weight %
8	Ambient temperature	°C		

Pump

9	Pump Name	3E-K4 100-160/2.2Q4Q1EGG TT	Frequency	Hz	50		
10	Design	IN-LINE CENTRIFUGAL PUMP	Installation type		STANDARD		
11	Manufacturer	EBARA	Impeller Diameter	Max.	mm		
12	Speed	rpm		1450	Designed	mm	
13	No. of Stage	1		Min.	mm	174	
14	Connection	Suction side	Flow	Operating	m³/h		
15	Connection	Discharge side		Max-	m³/h	108	
16	Max Working Pressure	kPa		1600	Min-	m³/h	36
17	Shut-off head	kPa	94.51	Head	Operating	m	
18	Total weight	kg	See the table of "Dimensions".		- (Qmax.)	m	5.1
19	Shaft power	kW			- (Qmin.)	m	9.1
20			Max. Shaft Power at max. impeller	kW	2.23		
21	Required pump NPSH	m	Efficiency	%			

Materials

22	Impeller	EN 1.4404 (AISI 316L)	
23	Casing cover	EN 1.4404 (AISI 316L)	
24	Casing	CAST IRON EN-GJL-250-EN-1561	
25	Shaft	EN 1.4404 (AISI 316L)	
26	O-ring	EPDM	
27	Bracket	ALUMINIUM	

Motor

28	Manufacturer	EPE standard	Insulation class	F	
29	Type	TEFC_3E-K_4_2.2_400_1	Phases	3~	
30	Specific design	IE3 / 50 Hz / Pole pairs 2	Frame size	100	
31	Rated power	kW	2.2	Weight	kg
32	Number of poles	4	Electric voltage	V	400
33	Speed	rpm	1450	Electric current	A
34	Degree of protection	IP 55			
35					

Remarks

Performance Curve

Pump Name

3E-K4 100-160/2.2Q4Q1EGG TT

Customer	Date	09.06.2024	Company
Contact	Item no.		Issued by
Phone	Project		Phone
E-mail	Project ID		E-mail

Requested data

1	Flow	m³/h	
2	Head	m	
3	Geodetic head	m	

Pump

Operating flow	m³/h		Frequency	Hz	50
Operating head	m		Number of poles		4
Impeller diameter designed	mm	174	Speed	rpm	1450

Test standard: ISO 9906:2012 - Grade3B

Water; 20°C; 998.3kg/m³; 1cSt

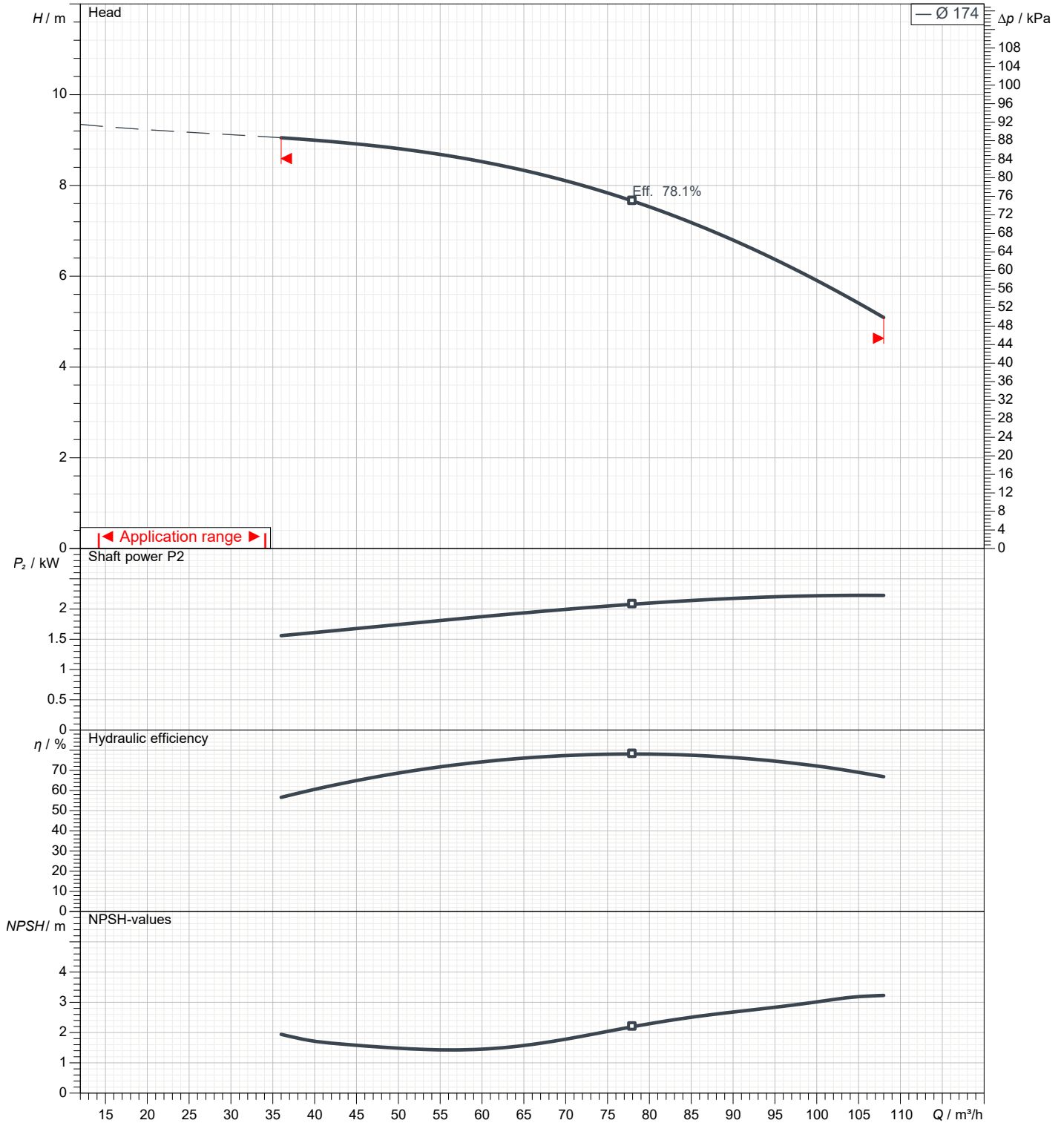

Dimensions

Pump name 3E-K4 100-160/2.2Q4Q1EGG TT

Customer	Date 09.06.2024	Company
Contact	Item no.	Issued by
Phone	Project	Phone
E-mail	Project ID	E-mail

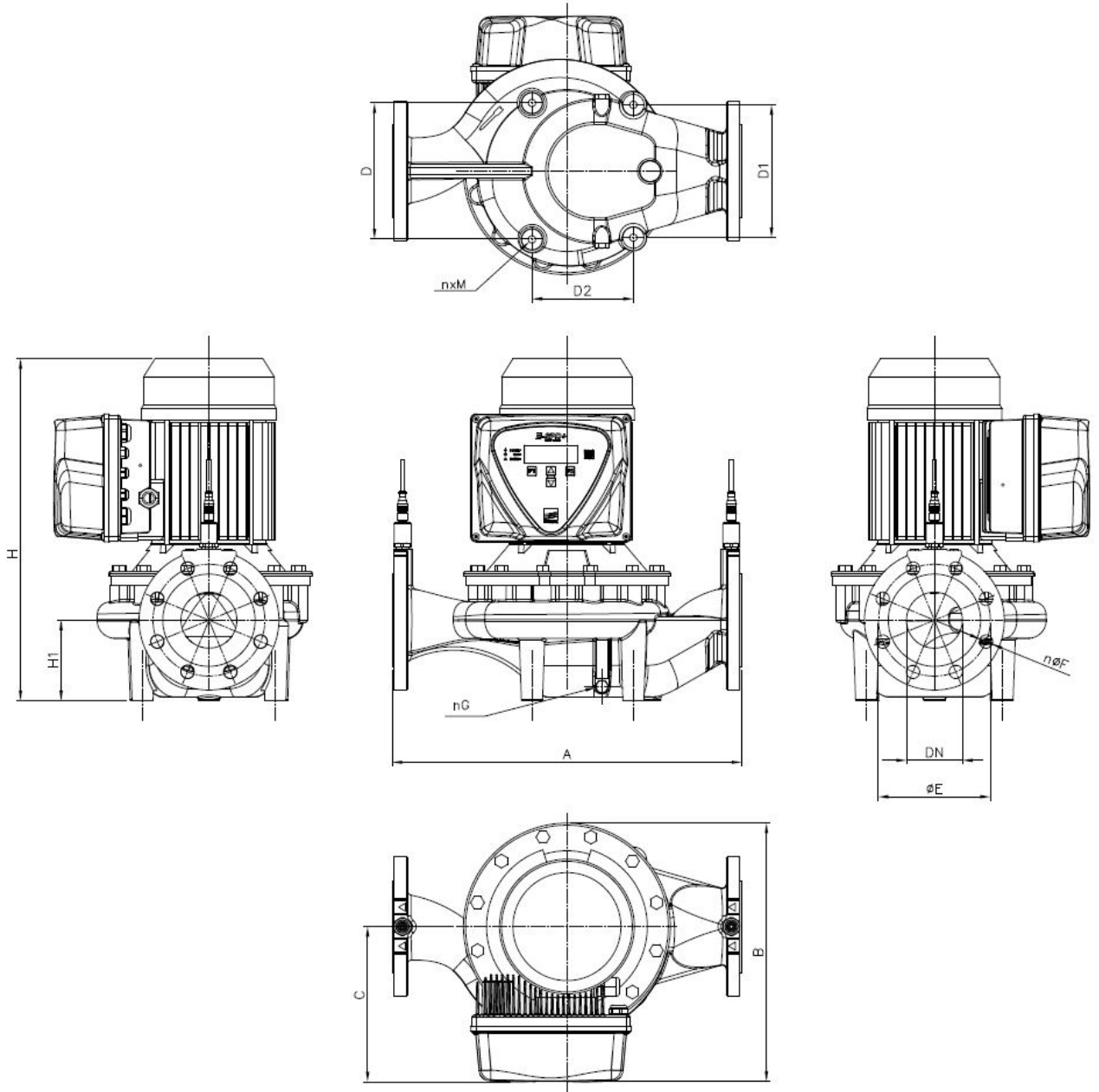

Dimensions in		mm						
1	A	550						
2	B	370						
3	C	222						
4	D1	200						
5	D2	185						
6	H	528						
7	H1	140						
8	nG	2-G1/4"						
9	nøF	8-ø19						
10	nxM	4xM12						
11	øE	180						
12	Weight P&M	57 kg						
13								
14								
15								

(1/2)

Construction

Pump name 3E-K4 100-160/2.2Q4Q1EGG TT

Customer	Date 09.06.2024	Company
Contact	Item no.	Issued by
Phone	Project	Phone
E-mail	Project ID	E-mail

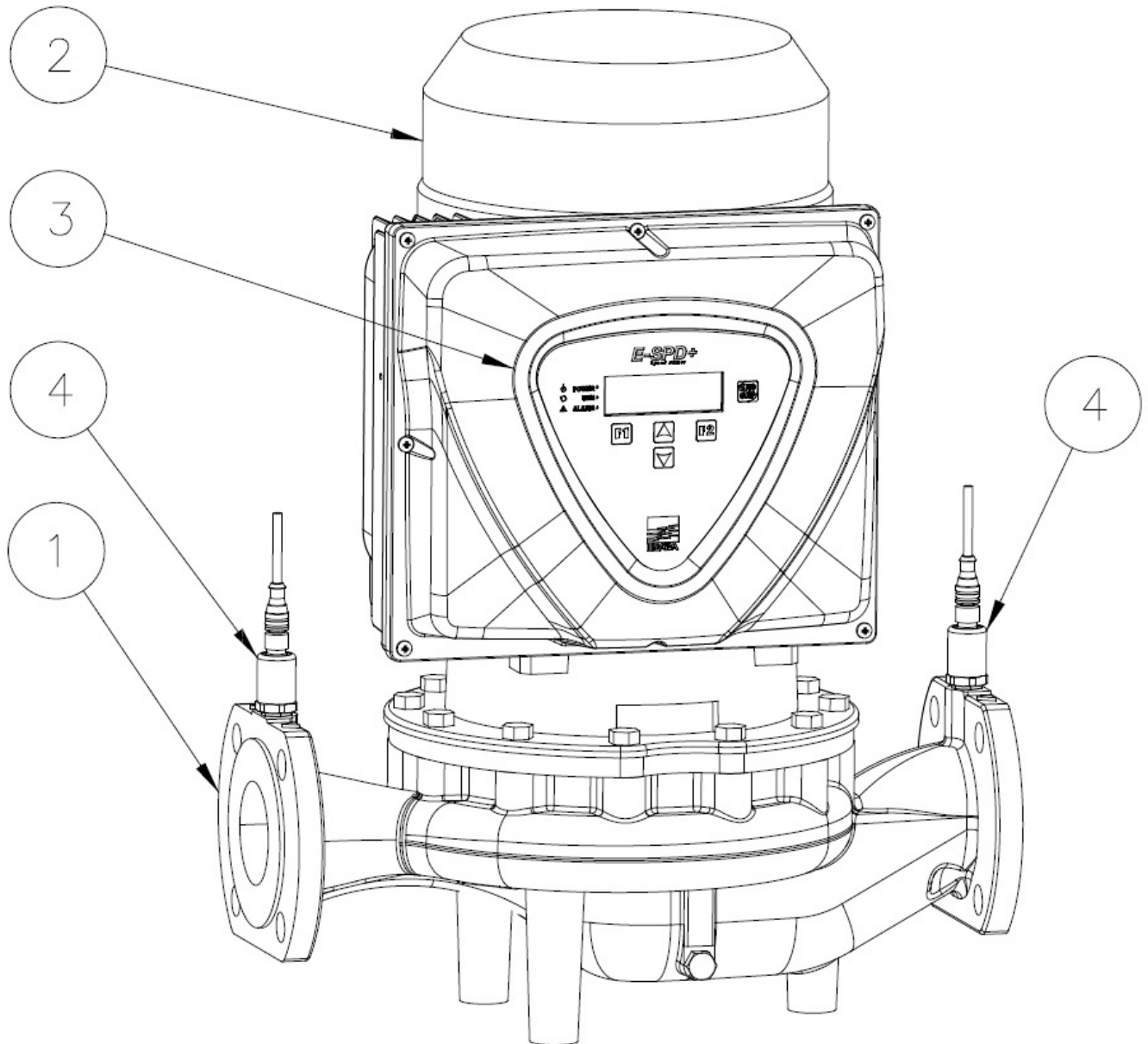

N°	PART NAME	Quantity
1	Pump	1
2	Electric motor	1
3	E-SPD+	1
4	Pressure transducer	2

(2/2)

Construction

Pump name 3E-K4 100-160/2.2Q4Q1EGG TT

Customer	Date 09.06.2024	Company
Contact	Item no.	Issued by
Phone	Project	Phone
E-mail	Project ID	E-mail

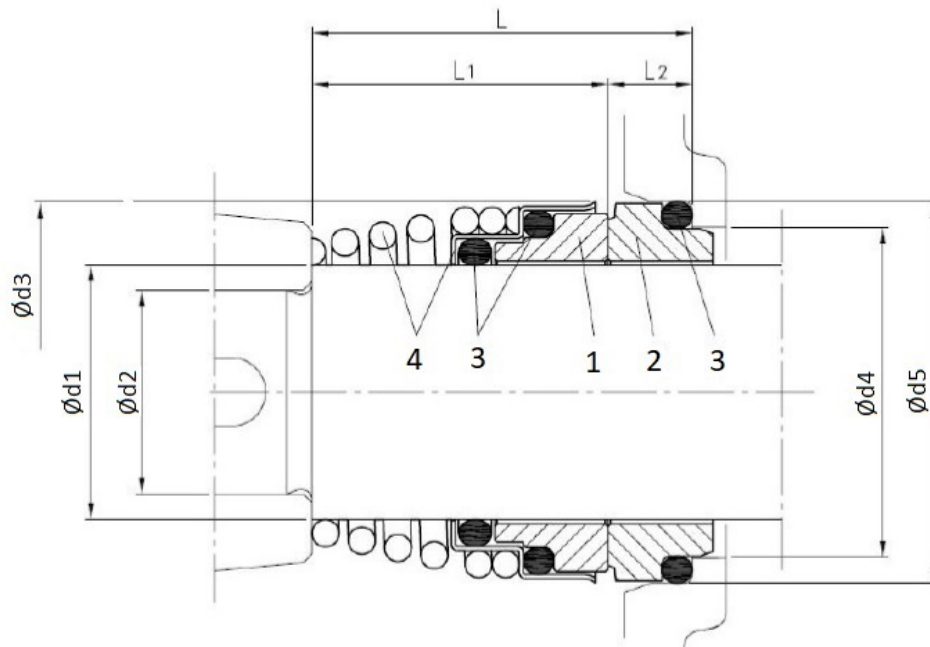

Version	Dimensions [mm]								Material			
	d1	d2	d3	d4	d5	L	L1	L2	1 Rotary seal ring	2 Stationary seal ring	3 Rubber	4 Frame + Spring
Option 1 (Q4Q1EGG)	22	19	36	31	37	37.5	27.5	10	Silicon Carbide graphite	Silicon Carbide	EPDM	EN 1.4401 (AISI 316)