

# Technical Data

Pump Name

3E-K 50-100/0,55Q1AEGG TT

Customer	Date	09.06.2024	Company
Contact	Item no.		Issued by
Phone	Project		Phone
E-mail	Project ID		E-mail

## Requested data

1	Pump type	IN-LINE CENTRIFUGAL PUMP	Fluid	Water	
2	Number of pumps / Reserve	1 / 0	Liquid temperature	°C	20
3	Flow	m³/h	Kin. viscosity	cSt	1.005
4	Head	m	Vapour pressure	kPa	2.34
5	Geodetic head	m	PH value		
6	Inlet pressure (pin)	kPa	Density	kg/m³	998.3
7	Available system NPSH		Solids	Weight %	0
8	Ambient temperature	°C	20		

## Pump

9	Pump Name	3E-K 50-100/0,55Q1AEGG TT	Frequency	Hz	50		
10	Design	IN-LINE CENTRIFUGAL PUMP	Installation type		STANDARD		
11	Manufacturer	EBARA	Impeller Diameter	Max.	mm	101	
12	Speed	rpm		2900	Designed	mm	101
13	No. of Stage	1		Min.	mm	101	
14	Connection	Suction side	Flow	Operating	m³/h		
15	Connection	Discharge side		Max-	m³/h	15	
16	Max Working Pressure	kPa		1000	Min-	m³/h	6
17	Shut-off head	kPa	111.15	Head	Operating	m	
18	Total weight	kg	See the table of "Dimensions".		- (Qmax.)	m	9.2
19	Shaft power	kW			- (Qmin.)	m	11.6
20			Max. Shaft Power at max. impeller	kW	0.55		
21	Required pump NPSH	m	Efficiency	%			

## Materials

22	Impeller	EN 1.4301 (AISI 304)		
23	Casing cover	EN 1.4301 (AISI 304)		
24	Casing	CAST IRON EN-GJL-250-EN-1561		
25	Shaft	EN 1.4301 (AISI 304)		
26	O-ring	EPDM		
27	Braket	ALUMINUM		

## Motor

28	Manufacturer	EPE Standard	Insulation class	F		
29	Type	TEFC_3E-K_2_0.55_400_1	Phases	3~		
30	Specific design	IE2 / 50 Hz / Pole pairs 1	Frame size	71		
31	Rated power	kW	0.55	Weight	kg	
32	Number of poles	2	Electric voltage	V	400	
33	Speed	rpm	2900	Electric current	A	1.7
34	Degree of protection	IP55				
35						

## Remarks

--

# Performance Curve

Pump Name

3E-K 50-100/0,55Q1AEGG TT

Customer	Date	09.06.2024	Company
Contact	Item no.		Issued by
Phone	Project		Phone
E-mail	Project ID		E-mail

## Requested data

1	Flow	m³/h	
2	Head	m	
3	Geodetic head	m	

## Pump

Operating flow	m³/h		Frequency	Hz	50
Operating head	m		Number of poles		2
Impeller diameter designed	mm	101	Speed	rpm	2900

Test standard: ISO 9906:2012 - Grade3B

Water; 20°C; 998.3kg/m³; 1cSt

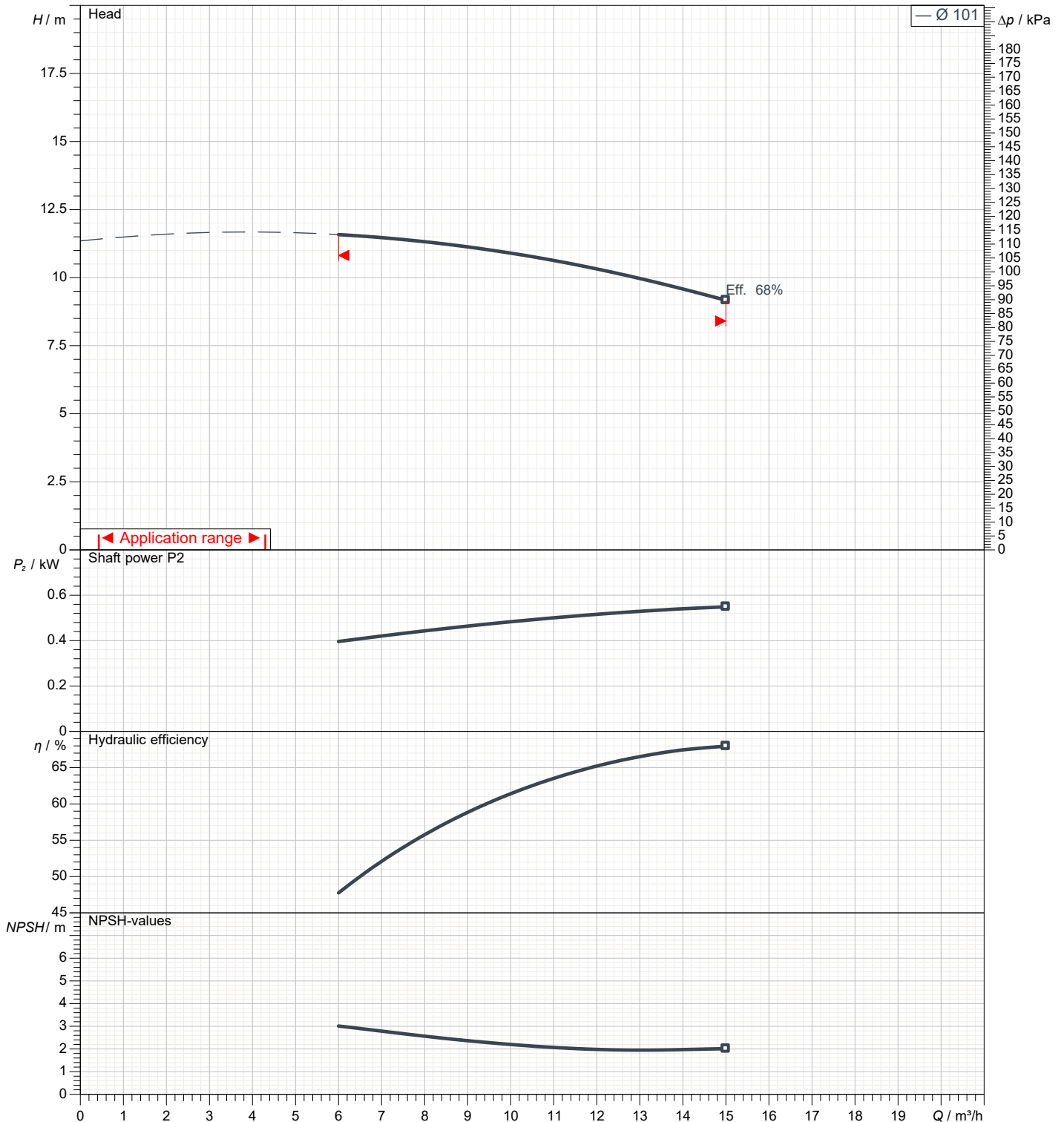

# Dimensions

Pump name 3E-K 50-100/0,55Q1AEGG TT

Customer	Date 09.06.2024	Company
Contact	Item no.	Issued by
Phone	Project	Phone
E-mail	Project ID	E-mail

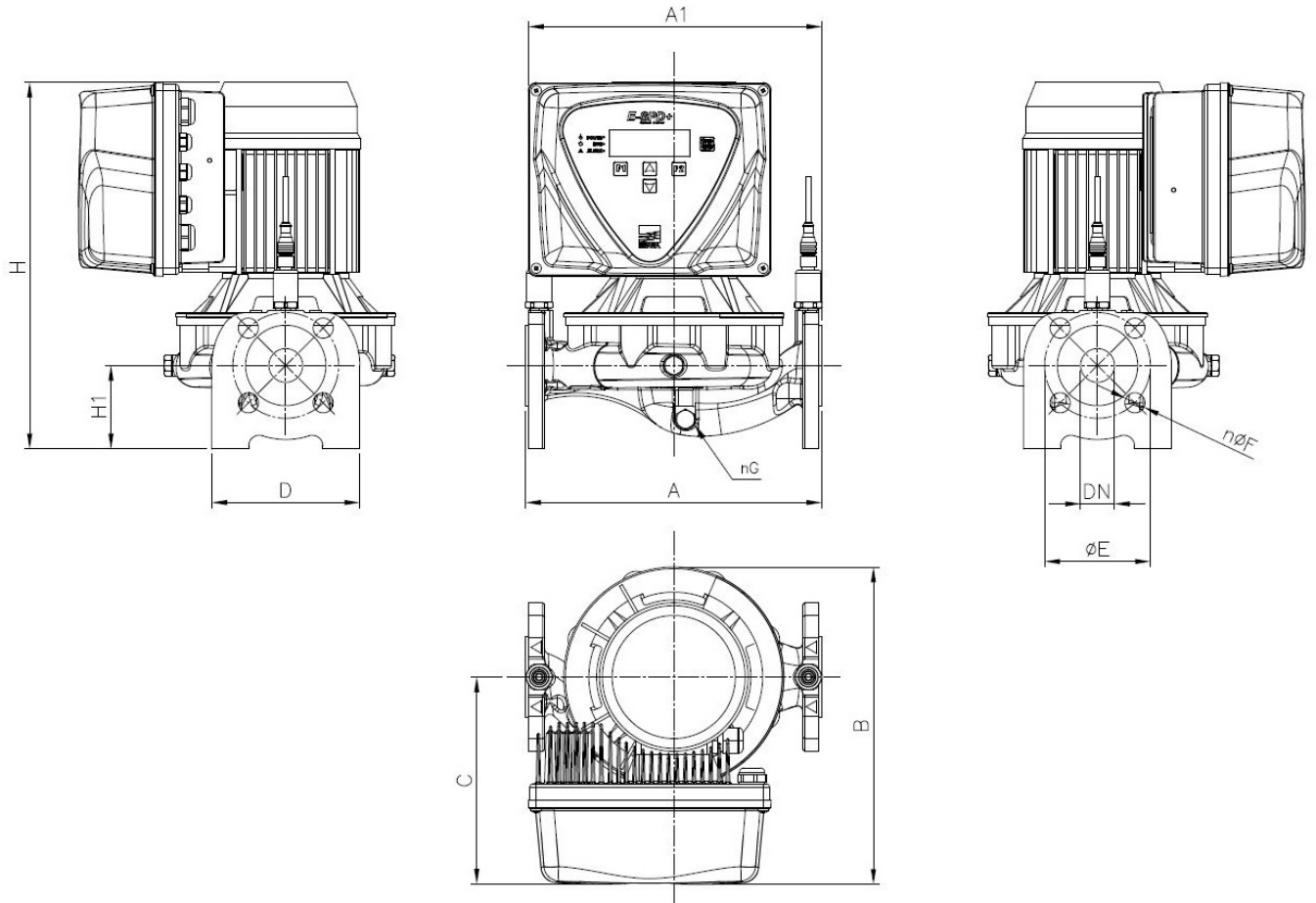

Dimensions in		mm						
1	A	280						
2	B	304						
3	C	196						
4	D	165						
5	H	352						
6	H1	75						
7	nG	4-G1/4"						
8	nØF	4-Ø19						
9	ØE	125						
10	Weight P&M	26 kg						
11								
12								
13								
14								
15								

(1/2)

# Construction

Pump name 3E-K 50-100/0,55Q1AEGG TT

Customer	Date 09.06.2024	Company
Contact	Item no.	Issued by
Phone	Project	Phone
E-mail	Project ID	E-mail

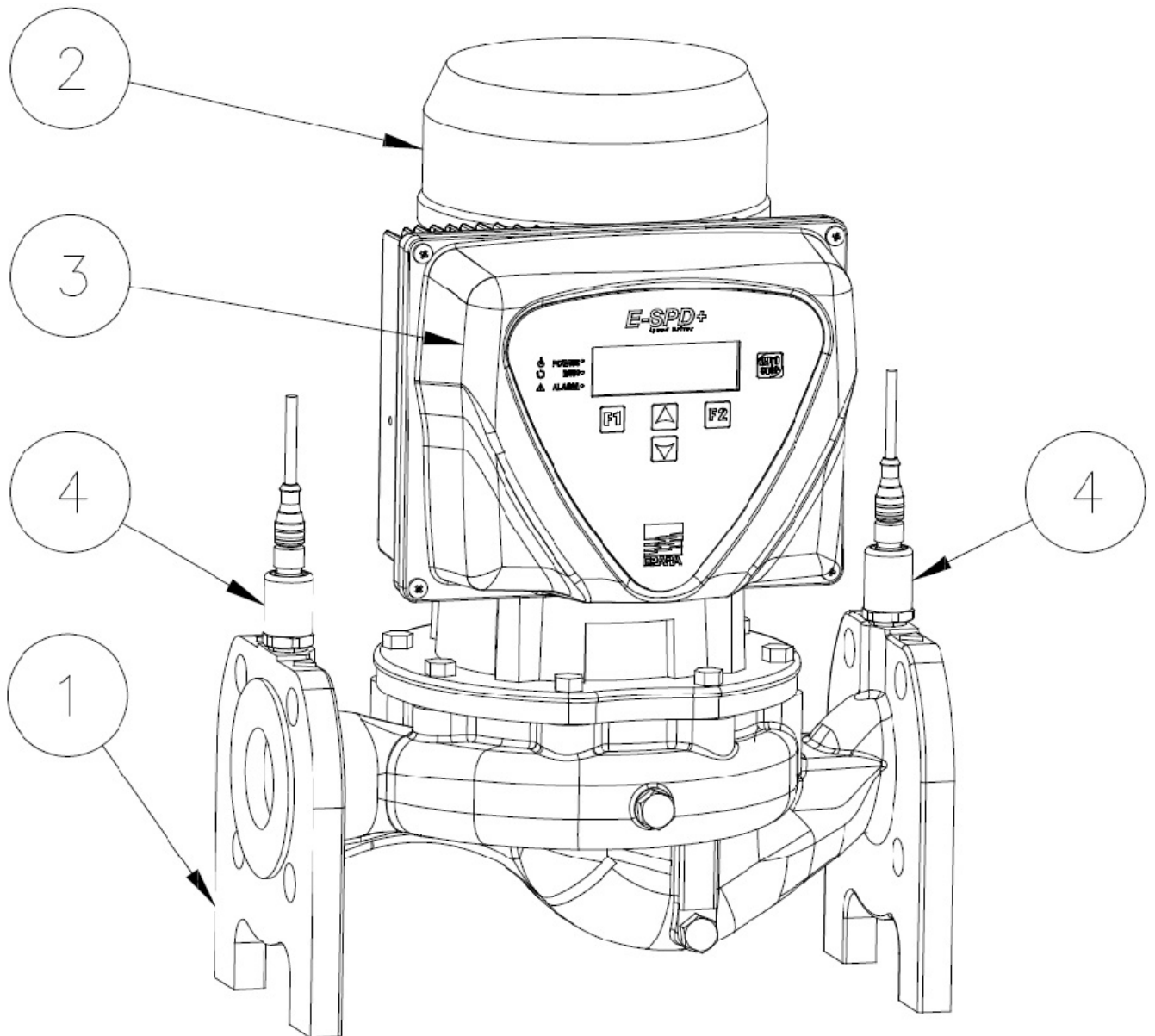

N°	PART NAME	Quantity
1	Pump	1
2	Electric motor	1
3	E-SPD+	1
4	Pressure transducer	2

(2/2)

# Construction

Pump name 3E-K 50-100/0,55Q1AEGG TT

Customer	Date 09.06.2024	Company
Contact	Item no.	Issued by
Phone	Project	Phone
E-mail	Project ID	E-mail

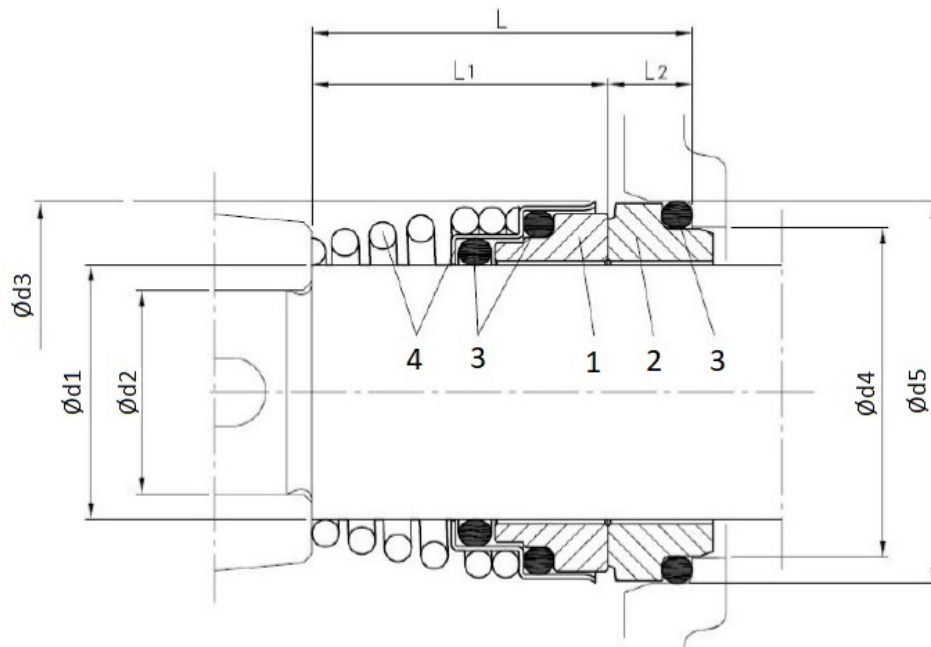

Version	Dimensions [ mm ]								Material			
	d1	d2	d3	d4	d5	L	L1	L2	1 Rotary seal ring	2 Stationary seal ring	3 Rubber	4 Frame + Spring
Standard (Q1AEGG)	15	12	26	21	26.9	29	22	7	Silicon Carbide	Metallised Carbon	EPDM	EN 1.4401 (AISI 316)