

Technical Data

Pump Name

3E-K 50-125/1,5Q1AEGG TT

Customer	Date	09.06.2024	Company
Contact	Item no.		Issued by
Phone	Project		Phone
E-mail	Project ID		E-mail

Requested data

1	Pump type	IN-LINE CENTRIFUGAL PUMP	Fluid	Water
2	Number of pumps / Reserve	1 / 0	Liquid temperature	°C
3	Flow	m³/h	Kin. viscosity	cSt
4	Head	m	Vapour pressure	kPa
5	Geodetic head	m	PH value	
6	Inlet pressure (pin)	kPa	Density	kg/m³
7	Available system NPSH		Solids	Weight %
8	Ambient temperature	°C		

Pump

9	Pump Name	3E-K 50-125/1,5Q1AEGG TT	Frequency	Hz	50	
10	Design	IN-LINE CENTRIFUGAL PUMP	Installation type		STANDARD	
11	Manufacturer	EBARA	Impeller Diameter	Max.	mm	
12	Speed	rpm		2900	Designed	mm
13	No. of Stage	1		Min.	mm	125
14	Connection	Suction side	Flow	Operating	m³/h	
15	Connection	Discharge side		Max-	m³/h	24
16	Max Working Pressure	kPa		1600	Min-	m³/h
17	Shut-off head	kPa	178.14	Head	Operating	m
18	Total weight	kg	See the table of "Dimensions".		- (Qmax.)	m
19	Shaft power	kW			- (Qmin.)	m
20			Max. Shaft Power at max. impeller	kW	1.51	
21	Required pump NPSH	m	Efficiency	%		

Materials

22	Impeller	EN 1.4301 (AISI 304)		
23	Casing cover	EN 1.4301 (AISI 304)		
24	Casing	CAST IRON EN-GJL-250-EN-1561		
25	Shaft	EN 1.4301 (AISI 304)		
26	O-ring	EPDM		
27	Bracket	ALUMINIUM		

Motor

28	Manufacturer	EPE Standard	Insulation class	F	
29	Type	TEFC_3E-K_2_1.5_400_1	Phases	3~	
30	Specific design	IE3 / 50 Hz / Pole pairs 1	Frame size	80	
31	Rated power	kW	1.5	Weight	kg
32	Number of poles	2	Electric voltage	V	400
33	Speed	rpm	2900	Electric current	A
34	Degree of protection	IP55			
35					

Remarks

Performance Curve

Pump Name

3E-K 50-125/1,5Q1AEGG TT

Customer	Date	09.06.2024	Company
Contact	Item no.		Issued by
Phone	Project		Phone
E-mail	Project ID		E-mail

Requested data

1	Flow	m³/h	
2	Head	m	
3	Geodetic head	m	

Pump

Operating flow	m³/h		Frequency	Hz	50
Operating head	m		Number of poles		2
Impeller diameter designed	mm	125	Speed	rpm	2900

Test standard: ISO 9906:2012 - Grade3B

Water; 20°C; 998.3kg/m³; 1cSt

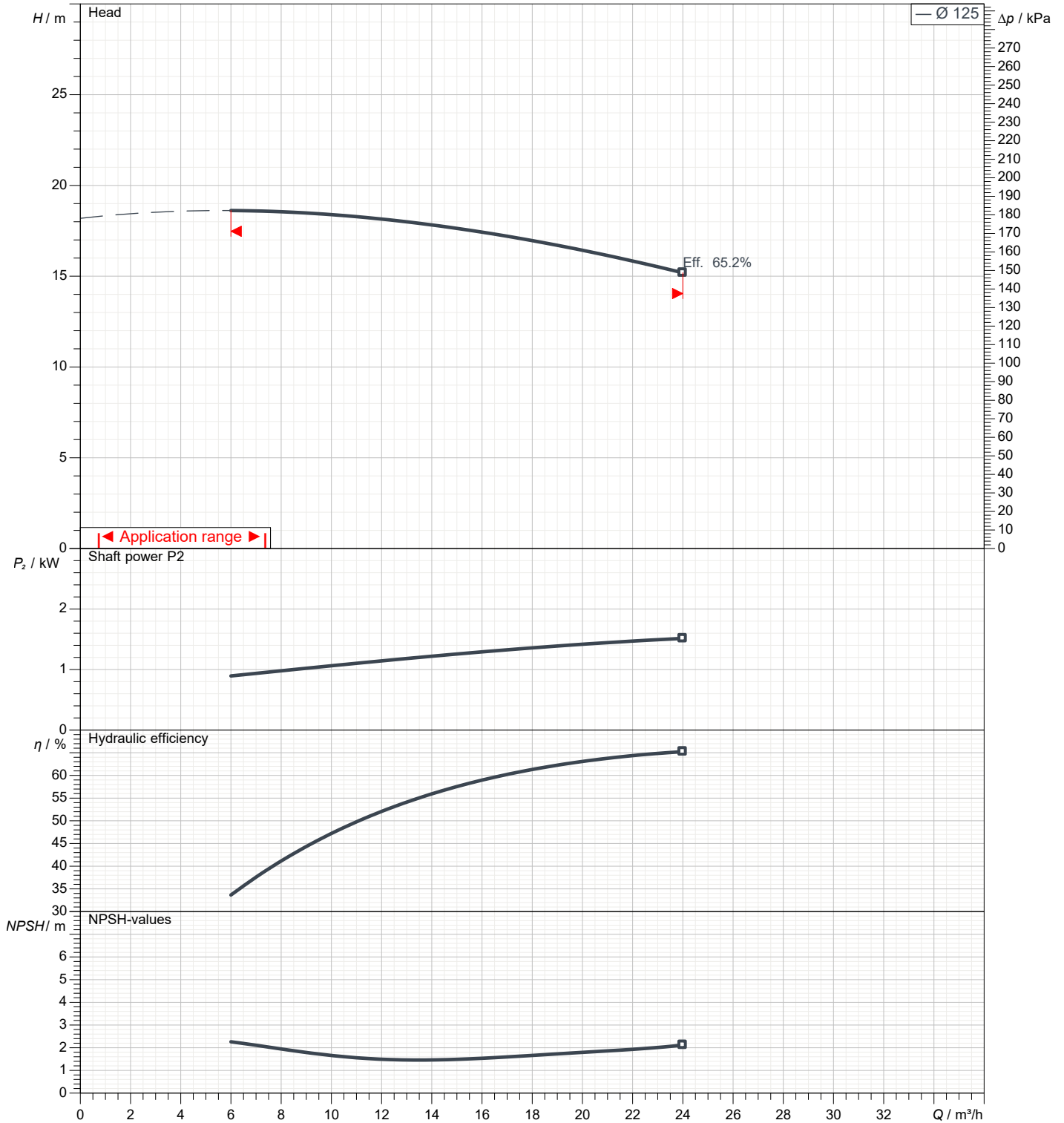

Dimensions

Pump name 3E-K 50-125/1,5Q1AEGG TT

Customer	Date 09.06.2024	Company
Contact	Item no.	Issued by
Phone	Project	Phone
E-mail	Project ID	E-mail

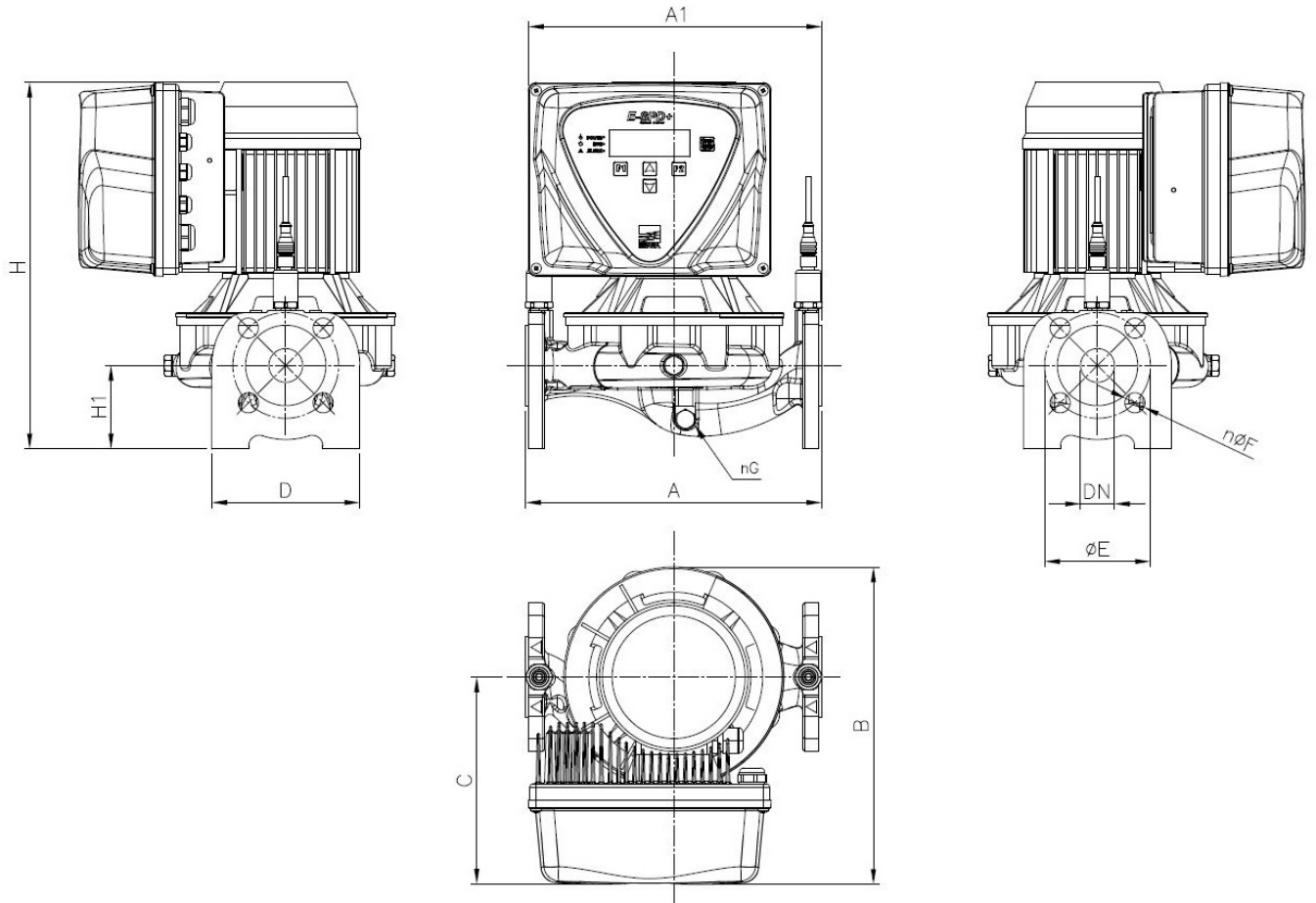

Dimensions in		mm						
1	A	340						
2	B	311						
3	C	205						
4	D	165						
5	H	441						
6	H1	115						
7	nG	4-G1/4"						
8	nØF	4-Ø19						
9	ØE	125						
10	Weight P&M	34 kg						
11								
12								
13								
14								
15								

(1/2)

Construction

Pump name 3E-K 50-125/1,5Q1AEGG TT

Customer	Date 09.06.2024	Company
Contact	Item no.	Issued by
Phone	Project	Phone
E-mail	Project ID	E-mail

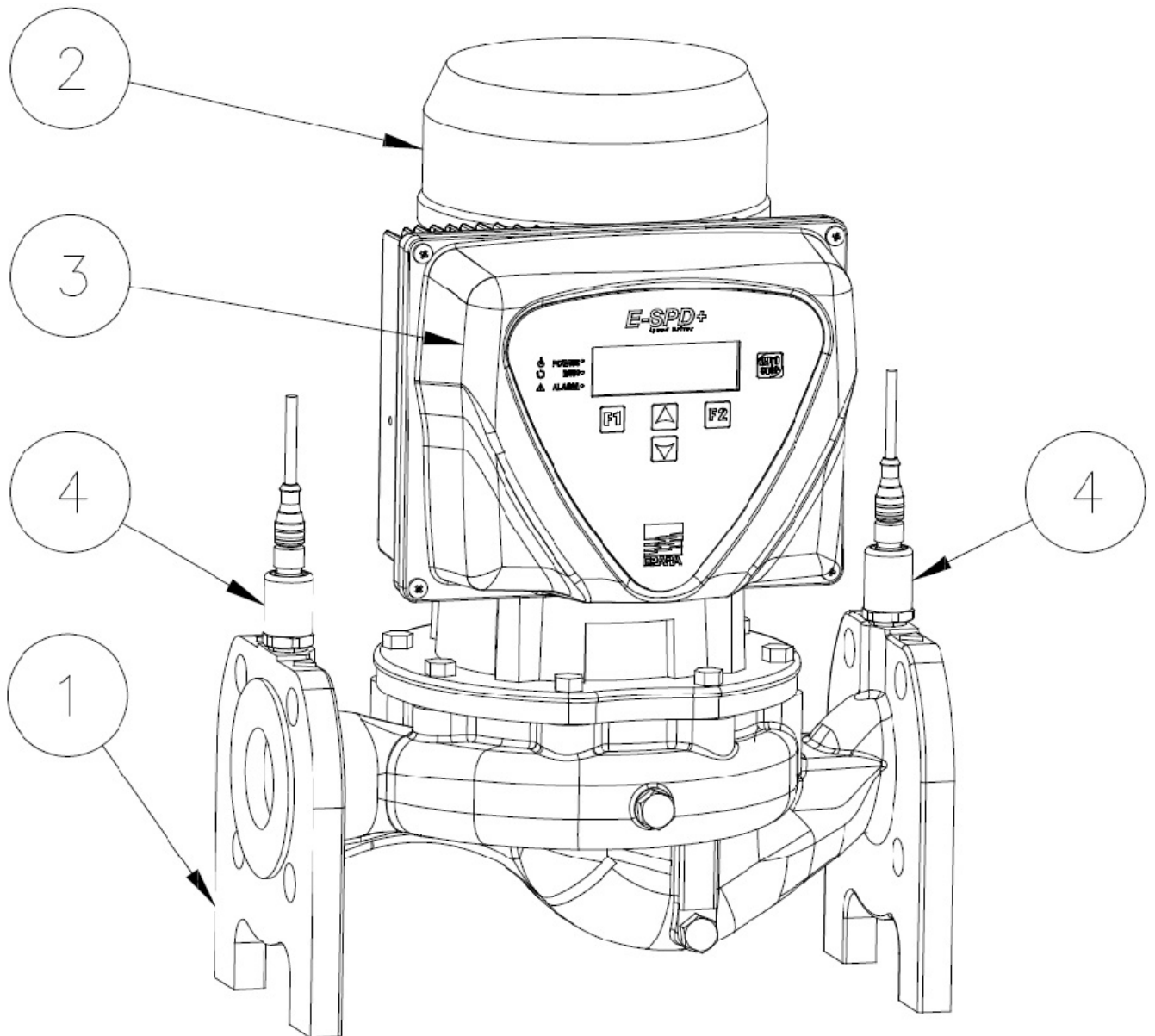

N°	PART NAME	Quantity
1	Pump	1
2	Electric motor	1
3	E-SPD+	1
4	Pressure transducer	2

(2/2)

Construction

Pump name 3E-K 50-125/1,5Q1AEGG TT

Customer	Date 09.06.2024	Company
Contact	Item no.	Issued by
Phone	Project	Phone
E-mail	Project ID	E-mail

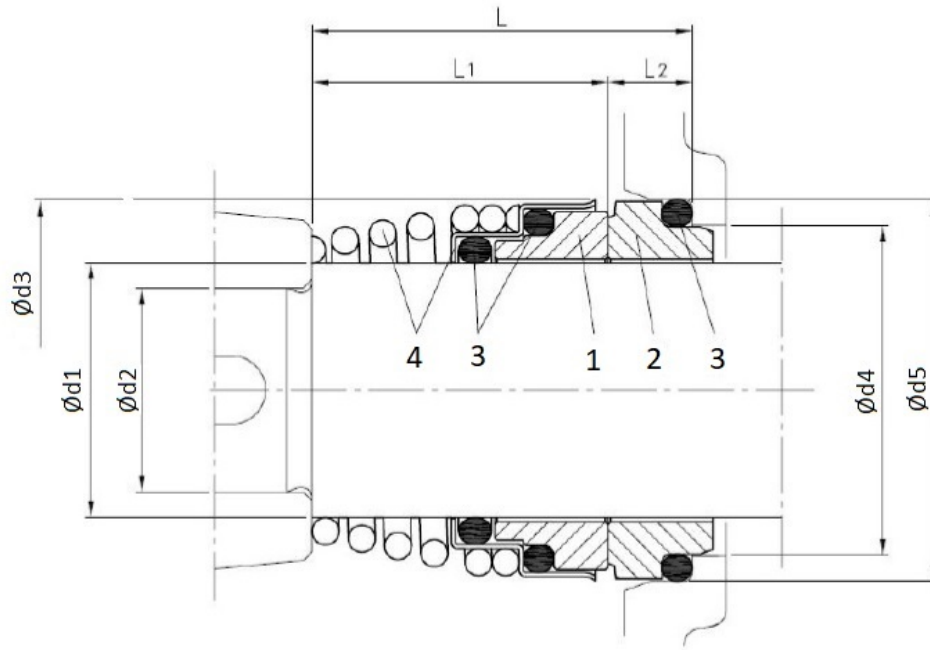

Version	Dimensions [mm]								Material			
	d1	d2	d3	d4	d5	L	L1	L2	1 Rotary seal ring	2 Stationary seal ring	3 Rubber	4 Frame + Spring
Standard (Q1AEGG)	22	19	36	31	37	37.5	27.5	10	Silicon Carbide	Metallised Carbon	EPDM	EN 1.4401 (AISI 316)