

Technical Data

Pump Name

3E4 40-200/0.55

Customer	Date	09.06.2024	Company
Contact	Item no.		Issued by
Phone	Project		Phone
E-mail	Project ID		E-mail

Requested data

1	Pump type	Inline vertical	Fluid	Water
2	Number of pumps / Reserve	1 / 0	Liquid temperature	°C
3	Flow	m³/h	Kin. viscosity	cSt
4	Head	m	Vapour pressure	kPa
5	Geodetic head	m	PH value	
6	Inlet pressure (pin)	kPa	Density	kg/m³
7	Available system NPSH		Solids	Weight %
8	Ambient temperature	°C		

Pump

9	Pump Name	3E4 40-200/0.55	Frequency	Hz	50	
10	Design	Inline vertical	Installation type		With motor	
11	Manufacturer	EBARA	Impeller Diameter	Max.	mm	
12	Speed	rpm		1450	Designed	mm
13	No. of Stage	1		Min.	mm	200
14	Connection	Suction side	EN	16k	Flow	
15	Connection	Discharge side	EN	16k		Operating
16	Max Working Pressure	kPa	1600	Max-		m³/h
17	Shut-off head	kPa	123.88	Head	Operating	
18	Total weight	kg	See the table of "Dimensions".		- (Qmax.)	m
19	Shaft power	kW			- (Qmin.)	m
20				Max. Shaft Power at max. impeller	kW	
21	Required pump NPSH	m		Efficiency	%	

Materials

22	Impeller	AISI 304	
23	Casing	Cast iron	
24	Shaft	AISI 304(wet extension)	
25			
26			
27			

Motor

28	Manufacturer	EPE Standard	Insulation class	F	
29	Type	TEFC_3E_4_0.55_230_1	Phases	3~	
30	Specific design	TEFC / 50 Hz / Pole pairs 2	Frame size	80	
31	Rated power	kW	0.55	Weight	kg
32	Number of poles	4	Electric voltage	V	230
33	Speed	rpm	1450	Electric current	A
34	Degree of protection	IP55			
35					

Remarks

Performance Curve

Pump Name

3E4 40-200/0.55

Customer	Date 09.06.2024	Company
Contact	Item no.	Issued by
Phone	Project	Phone
E-mail	Project ID	E-mail

Requested data

1	Flow	m³/h	
2	Head	m	
3	Geodetic head	m	

Pump

Operating flow	m³/h	Frequency	Hz	50	
Operating head	m	Number of poles		4	
Impeller diameter designed	mm	200	Speed	rpm	1450

Test standard: ISO 9906:2012 - Grade3B

Water; 20°C; 998.3kg/m³; 1cSt

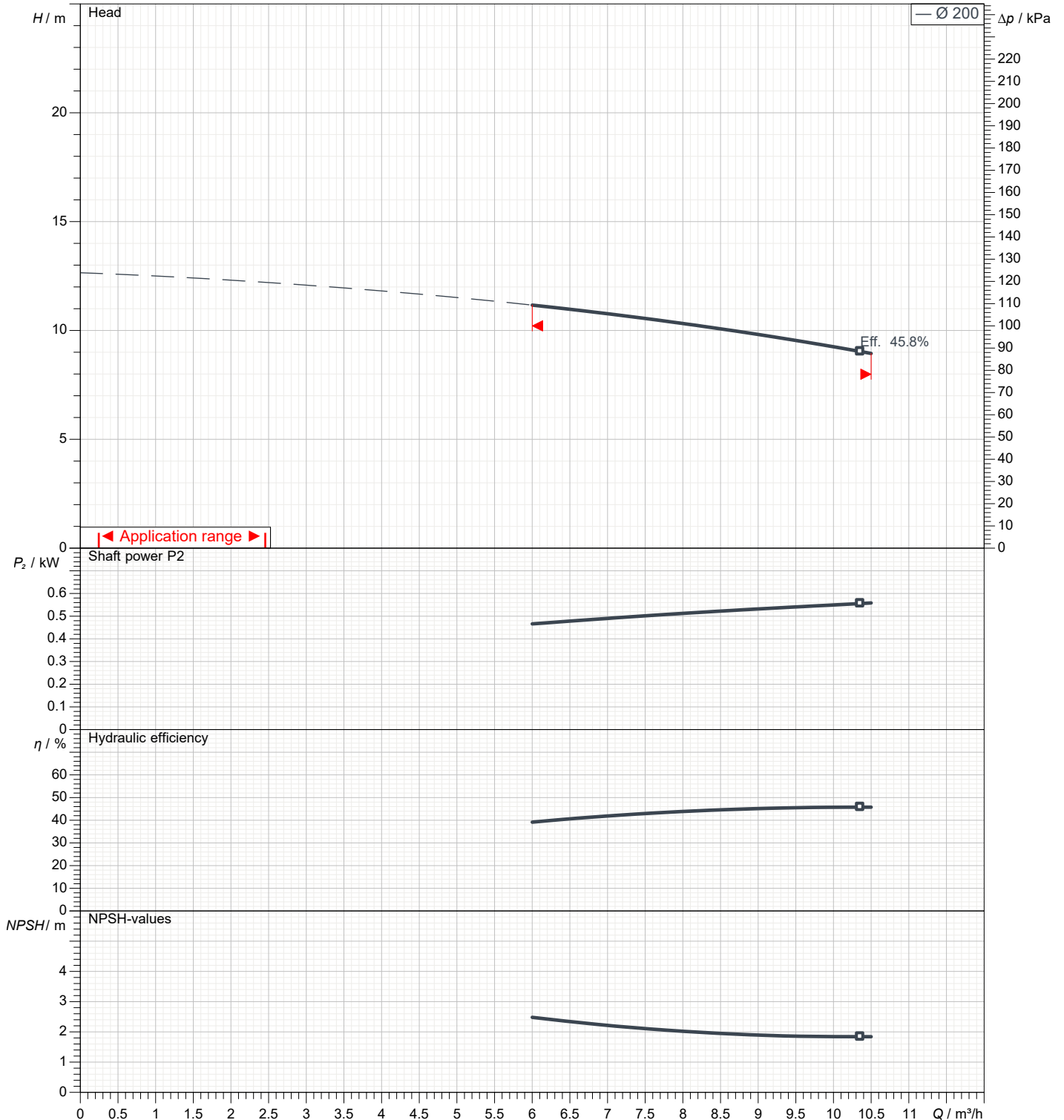

Dimensions

Pump Name 3E4 40-200/0.55

Customer	Date 09.06.2024	Company
Contact	Item no.	Issued by
Phone	Project	Phone
E-mail	Project ID	E-mail

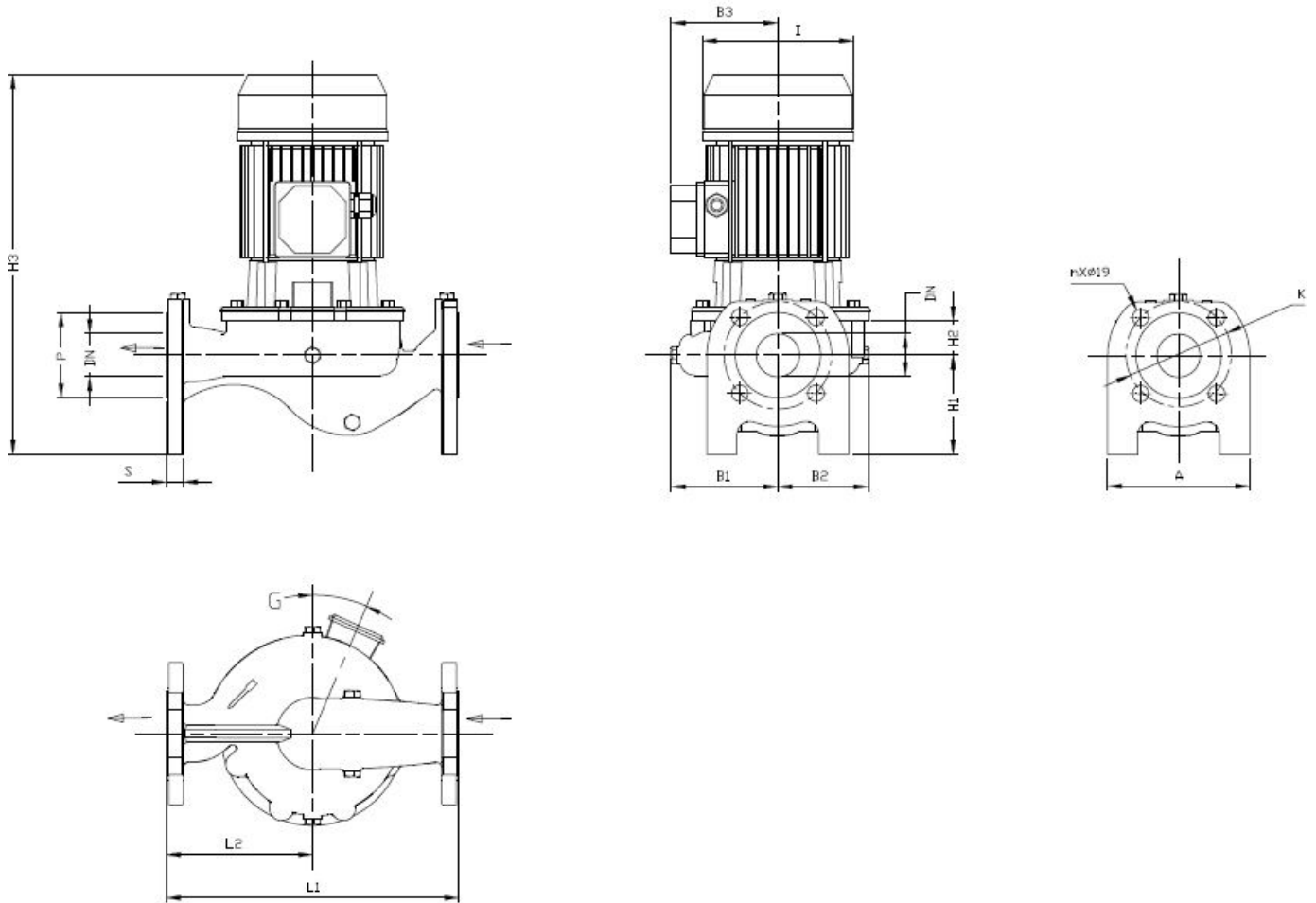

Dimensions in		mm						
1	A	150	Φ K	110				
2	B1	146	Φ P	84				
3	B2	146						
4	B3	119						
5	G	15						
6	H1	100						
7	H2	50						
8	H3	412						
9	I	159						
10	L1	340						
11	L2	170						
12	n	4(Num)						
13	S	18						
14	Weight P&M	30.2 kg						
15	Φ DN	40						

(1/3)

Construction

Pump Name 3E4 40-200/0.55

Customer	Date 09.06.2024	Company
Contact	Item no.	Issued by
Phone	Project	Phone
E-mail	Project ID	E-mail

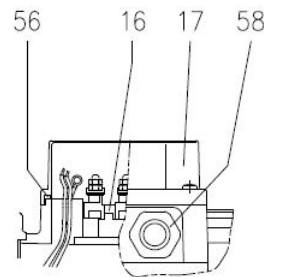
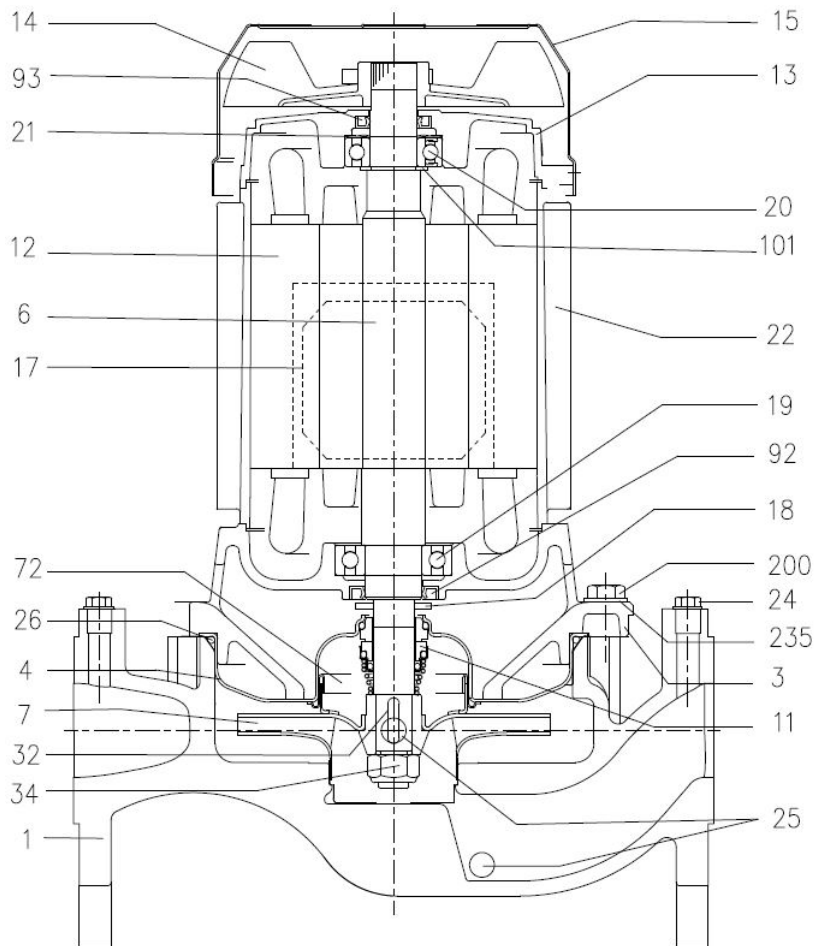

(2/3)**Construction****Pump Name 3E4 40-200/0.55**

Customer	Date 09.06.2024	Company
Contact	Item no.	Issued by
Phone	Project	Phone
E-mail	Project ID	E-mail

No	PART NAME	MATERIAL	DIMENSIONS	STANDARD	QTY
1	Casing	Cast iron EN-GJL-250-EN 1561			1
3	Motor bracket	[4]			1
4	Casing cover	EN 1.4301(AISI 304)			1
6	Shaft with rotor-Part in contact with	EN 1.4301(AISI 304)			1
7	Impeller	EN 1.4301(AISI 304)			1
11	Mechanical seal [2]	SiC/met. Carbon/EPDM			1
12	Motor frame with stator	-			1
13	Motor cover	Aluminium			1
14	Fan	PA			1
15	Fan cover	Fe P04 Galvanized			1
16	Terminal				1
17	Terminal box cover	Aluminium (three phase version)			1
18	Splash ring	NBR	40x21.5x2	EBARA DRAWING	1
19	Bearing		See table		1
20	Bearing		See table		1
21	Adjusting ring	Steel C70			1
22	Tie rod	Fe 42 Galvanized	M5	EBARA	4
24	Plug	Brass	G1/4	DIN 906	2
25	Drain plug	Brass	G1/4	DIN 906	4
26	O ring	EPDM[3]	227.96x5.34	OR 6895	1
32	Key	EN 1.4401(AISI 316)	6x6x25	UNI 6604	1
34	Impeller nut	EN 1.4301(AISI 304)	M16x1.5	UNI 7474	1
56	Box gasket	NBR			1
58	Fastening nut				1
72	Casing ring (not for 80 version) [1]	EN 1.4301 (AISI 304)			1
92	Lip seal	-	25x40x7	DIN 3760	1
	Upto 1.5kW		30x47X7	without spring	
	From 2.2kW to 3kW		15x30x5	DIN 3760	1
93	Lip seal	-	17x32X7	without spring	
	For 0.25kW		25x40x7		
	For 0.37kW and 0.55kW				
	From 0.75 kW to 3kW				
200	Screw	Gv. Steel 8.8 strength class ISO 898/1	M10x35	UNI 5739	12
235	Washer	Galvanized Steel	8.4x17	UNI 6592	12

[1] For Version 32-200,40-200,50-200,65-160,65-200

[2] Special version: see mechanical seal page

[3] FPM for Q1AVGG

EPDM for Q1AEGG, Q4Q1EGG

[4] Cast iron EN-GJL-200-EN 1561 for models with 15,18.5, 22 kW motor

Aluminum AL-EN-1706-AC-46000-D for all the others

(3/3)

Construction

Pump Name 3E4 40-200/0.55

Customer	Date 09.06.2024	Company
Contact	Item no.	Issued by
Phone	Project	Phone
E-mail	Project ID	E-mail

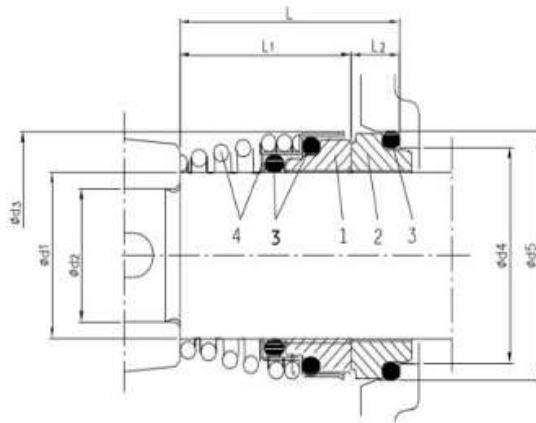

Version	Pump type	Dimensions [mm]								Material			
		d1	d2	d3	d4	d5	L	L1	L2	1 Rotary seal ring	2 Stationary seal ring	3 Rubber	4 Frame + Spring
Standard (Q1AEGG)	32-160/200 40-160/200 50-125/160/200 65-125/160/200 80-160/200 100-160	22	19	36	31	37	37.5	27.5	10	Silicon Carbide	Metallised Carbon	EPDM	EN 1.4401 (AISI 316)