

Technical Data

Booster set name

3GPE EVMSG10 14N5/5,5 ESPT

Customer	Date	09.06.2024	Company
Contact	Item no.		Issued by
Phone	Project		Phone
E-mail	Project ID		E-mail

Requested data

1	Pump type	Booster Set	Fluid	Water
2	Number of pumps	3	Liquid temperature °C	20
3	Flow m ³ /h		Kin. viscosity cSt	1.005
4	Head m		Vapour pressure kPa	2.34
5	Geodetic head m		PH value	
6	Inlet pressure kPa	0	Density kg/m ³	998.3
7	Available system NPSH	Ask our technical department.	Solids Weight %	0
8	Ambient temperature °C	20	Installation height m	100

Booster Set

9	Booster set name	3GPE EVMSG10 14N5/5,5 ESPT	Frequency Hz	50	
10	Design	Booster Set			
11	Manufacturer	EBARA	Impeller Dia.	Max. mm	96
12	Speed rpm	2930		Designed mm	96
13	No. of Stage	14		Min. mm	96
14	Connection Suction side	UNI EN ISO 228 PN16	Flow	Operating m ³ /h	
15	Connection Discharge side	UNI EN ISO 228 PN16		Max- m ³ /h	15
16	Max Working Pressure kPa	1600		Min- m ³ /h	4.5
17	Shut-off head kPa	1524.67	Head	Operating m	
18	Total weight kg	See the table of "Dimensions".		- (Qmax.) m	72.1
19	Shaft power kW			- (Qmin.) m	151.7
20			Max. Shaft Power at max. impeller kW	5.17	
21	Required NPSH m		Efficiency %		

Materials

22	Frame	Galvanized steel	Shaft	AISI 304
23	Manifold	AISI 304	O-ring	EPDM
24	Check valve	Brass / NBR		
25	Ball / Butterfly valve	Brass / PTFE		
26	Impeller	AISI 304		
27	Casing	Cast iron		

Motor

28	Manufacturer	ETM	Insulation class	F
29	Type	TEFC_EVMS10 14/5.5_400_Three Phase	Phases	3~
30	Specific design	IE3 / 50 Hz / Pole pairs 1	Frame size	132
31	Rated power kW	5.5	Weight; motor kg	39
32	Number of poles	2	Electric voltage V	400
33	Speed rpm	2925	Electric current A	10.4
34	Degree of protection	IP 55		
35				

Remarks

--

Performance curve

Booster set name

3GPE EVMSG10 14N5/5,5 ESPT

Customer	Date 09.06.2024	Company
Contact	Item no.	Issued by
Phone	Project	Phone
E-mail	Project ID	E-mail

Requested data

1	Flow	m³/h	
2	Head	m	
3	Geodetic head	m	

Booster set

Operating flow	m³/h	Frequency	Hz	50
Operating head	m	Number of poles		2
ImpellerDiameter Designed	mm	Speed	rpm	2930

Test standard: ISO 9906:2012 - Grade3B

Water; 20°C; 998.3kg/m³; 1cSt

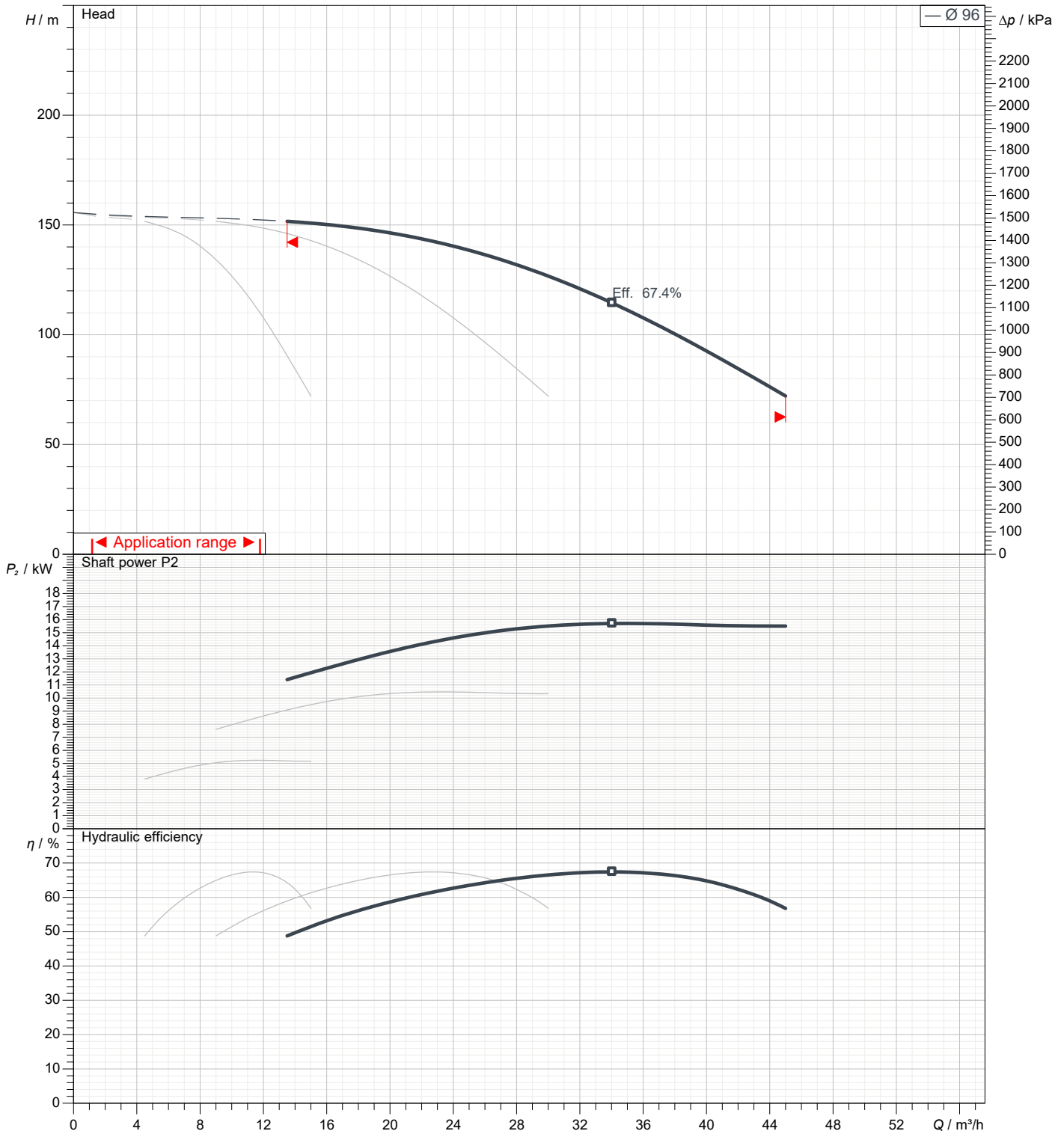

Dimensions

Booster set name

3GPE EVMSG10 14N5/5,5 ESPT

Customer	Date 09.06.2024	Company
Contact	Item no.	Issued by
Phone	Project	Phone
E-mail	Project ID	E-mail

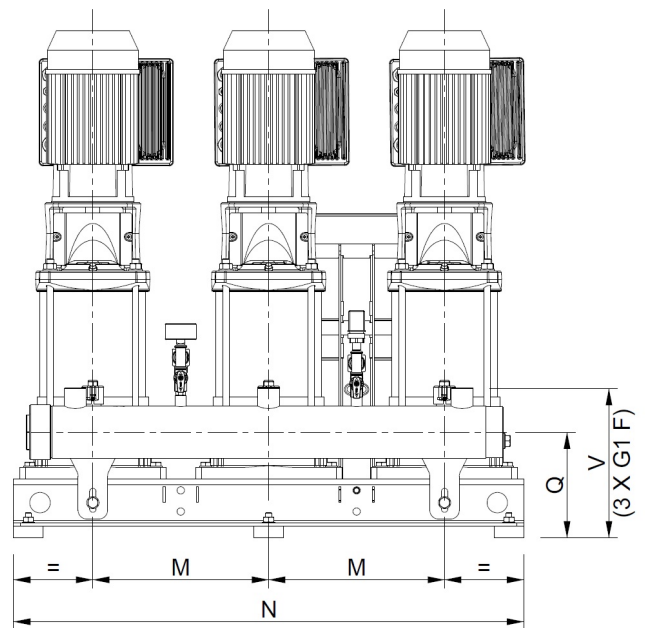
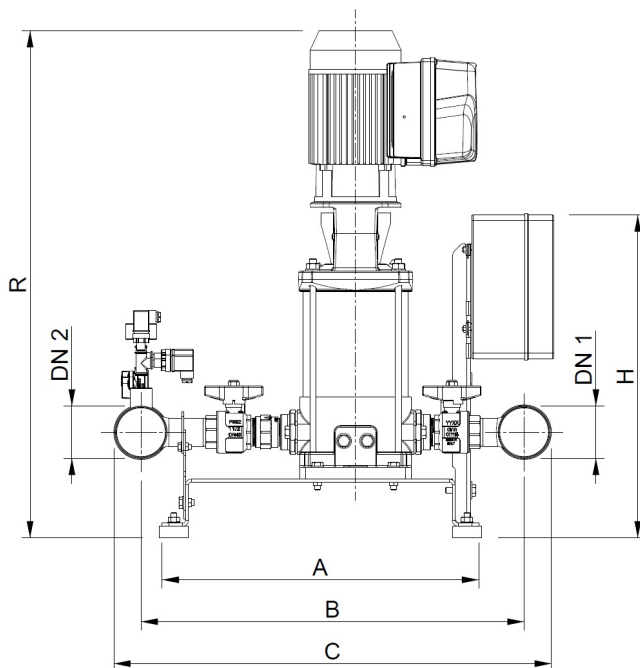

Dimensions in		mm						
1	A	540						
2	B	655						
3	C	745						
4	DN1	G3						
5	DN2	G3						
6	H	640						
7	M	400						
8	N	1070						
9	Q	180						
10	R	1320						
11	V	255						
12	Weight kg	199						
13								
14								
15								

(1/2) Construction

Booster set name

3GPE EVMSG10 14N5/5,5 ESPT

Customer	Date 09.06.2024	Company
Contact	Item no.	Issued by
Phone	Project	Phone
E-mail	Project ID	E-mail

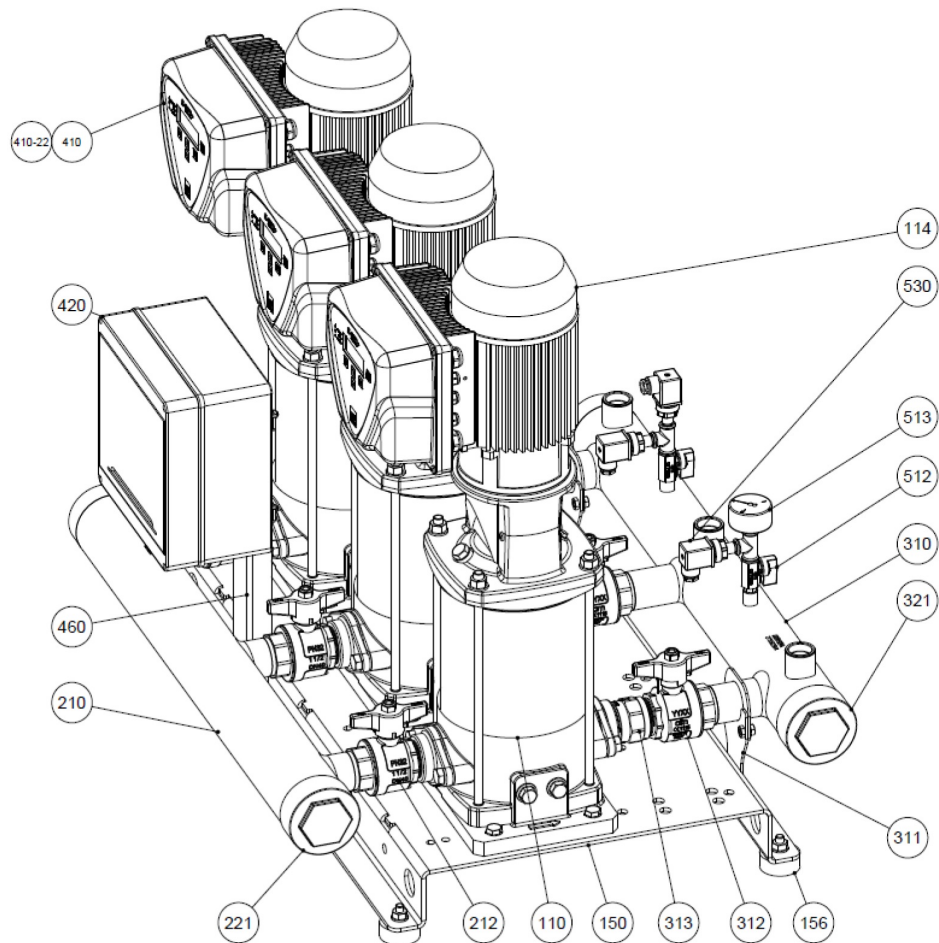

N°	PART NAME	MATERIAL	Quantity
110	Principal pump	-	3
114	Electric motor	-	3
150	Baseplate	Galvanized steel	1
156	Baseplate foot	SBR	6
210	Suction manifold	AISI 304	1
211	Manifold bracket	Galvanized steel	2
212	Ball valve	Brass / P.T.F.E.	3
221	Threaded female cap	AISI 304	1
310	Discharge manifold	AISI 304	1
311	Manifold bracket	Galvanized steel	2
312	Ball valve	Brass / P.T.F.E.	3
313	Check valve	Brass / NBR	3
321	Threaded female cap	AISI 304	1
410	E-SPD+	-	3
410-22	E-SPD+ adaptor	-	3
420	Protection panel	-	1
460	Protection panel frame	Galvanized steel	1
512	Ball valve	Brass / P.T.F.E.	2
513	Pressure gauge	Copper alloy / plastic	1
530	Pressure transmitter	-	3

(2/2) Construction

Booster set name
3GPE EVMSG10 14N5/5,5 ESPT

Customer	Date 09.06.2024	Company
Contact	Item no.	Issued by
Phone	Project	Phone
E-mail	Project ID	E-mail

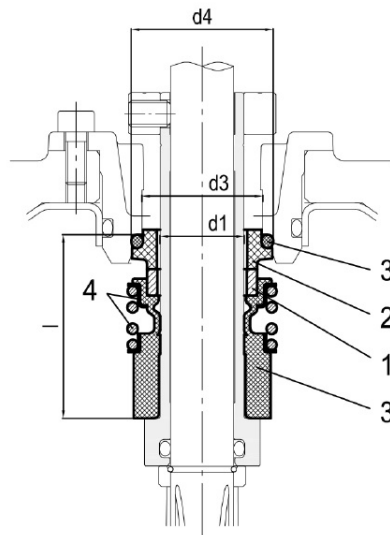

● : Standard

Pump model	Max operating pressure	Max operating temperature	Shaft seal type		Shaft seal material							Type key		
			Cartridge		1		2		3		4		5	
			Unbalanced	Balanced	Rotating Part	Code	Stationary Part	Code	Elastomers	Code	Compression spring		Collar	Code
up to 16 bar	- 30°C to + 120°C	●		SiC	(Q1)	Carbon	(B)	EPDM	(E)	AlSi 316		(G)	Q1BEG	

Max operating pressure	d1	d2	d3	d4	l
	[mm]	[mm]	[mm]	[mm]	[mm]
16 bar	20	-	29	35	37.5