

Technical Data

Booster set name

3GPE EVMSG5 4N5/0,75 ESPM

Customer	Date	09.06.2024	Company
Contact	Item no.		Issued by
Phone	Project		Phone
E-mail	Project ID		E-mail

Requested data

1	Pump type	Booster Set	Fluid	Water
2	Number of pumps	3	Liquid temperature °C	20
3	Flow m³/h		Kin. viscosity cSt	1.005
4	Head m		Vapour pressure kPa	2.34
5	Geodetic head m		PH value	
6	Inlet pressure kPa	0	Density kg/m³	998.3
7	Available system NPSH	Ask our technical department.	Solids Weight %	0
8	Ambient temperature °C	20	Installation height m	100

Booster Set

9	Booster set name	3GPE EVMSG5 4N5/0,75 ESPM	Frequency Hz	50
10	Design	Booster Set		
11	Manufacturer	EBARA	Impeller Dia.	Max. mm 91
12	Speed rpm	2850		Designed mm 91
13	No. of Stage	4		Min. mm 91
14	Connection Suction side	UNI EN ISO 228 PN16	Flow	Operating m³/h
15	Connection Discharge side	UNI EN ISO 228 PN16		Max- m³/h 7.8
16	Max Working Pressure kPa	1600		Min- m³/h 2.4
17	Shut-off head kPa	358.36	Head	Operating m
18	Total weight kg	See the table of "Dimensions".		- (Qmax.) m 19.1
19	Shaft power kW			- (Qmin.) m 34.7
20			Max. Shaft Power at max. impeller kW	0.74
21	Required NPSH m		Efficiency %	

Materials

22	Frame	Galvanized steel	Shaft	AISI 304
23	Manifold	AISI 304	O-ring	EPDM
24	Check valve	Brass / NBR		
25	Ball / Butterfly valve	Brass / PTFE		
26	Impeller	AISI 304		
27	Casing	Cast iron		

Motor

28	Manufacturer	ETM	Insulation class	F
29	Type	TEFC_EVMS5 4/0.75_230_Three Phase	Phases	3~
30	Specific design	IE3 / 50 Hz / Pole pairs 1	Frame size	80
31	Rated power kW	0.75	Weight; motor kg	8.5
32	Number of poles	2	Electric voltage V	230
33	Speed rpm	2845	Electric current A	3
34	Degree of protection	IP 55		
35				

Remarks

Performance curve

Booster set name

3GPE EVMSG5 4N5/0,75 ESPM

Customer	Date	09.06.2024	Company
Contact	Item no.		Issued by
Phone	Project		Phone
E-mail	Project ID		E-mail

Requested data

1	Flow	m³/h	
2	Head	m	
3	Geodetic head	m	

Booster set

Operating flow	m³/h		Frequency	Hz	50
Operating head	m		Number of poles		2
ImpellerDiameter Designed	mm	91	Speed	rpm	2850

Test standard: ISO 9906:2012 - Grade3B

Water; 20°C; 998.3kg/m³; 1cSt

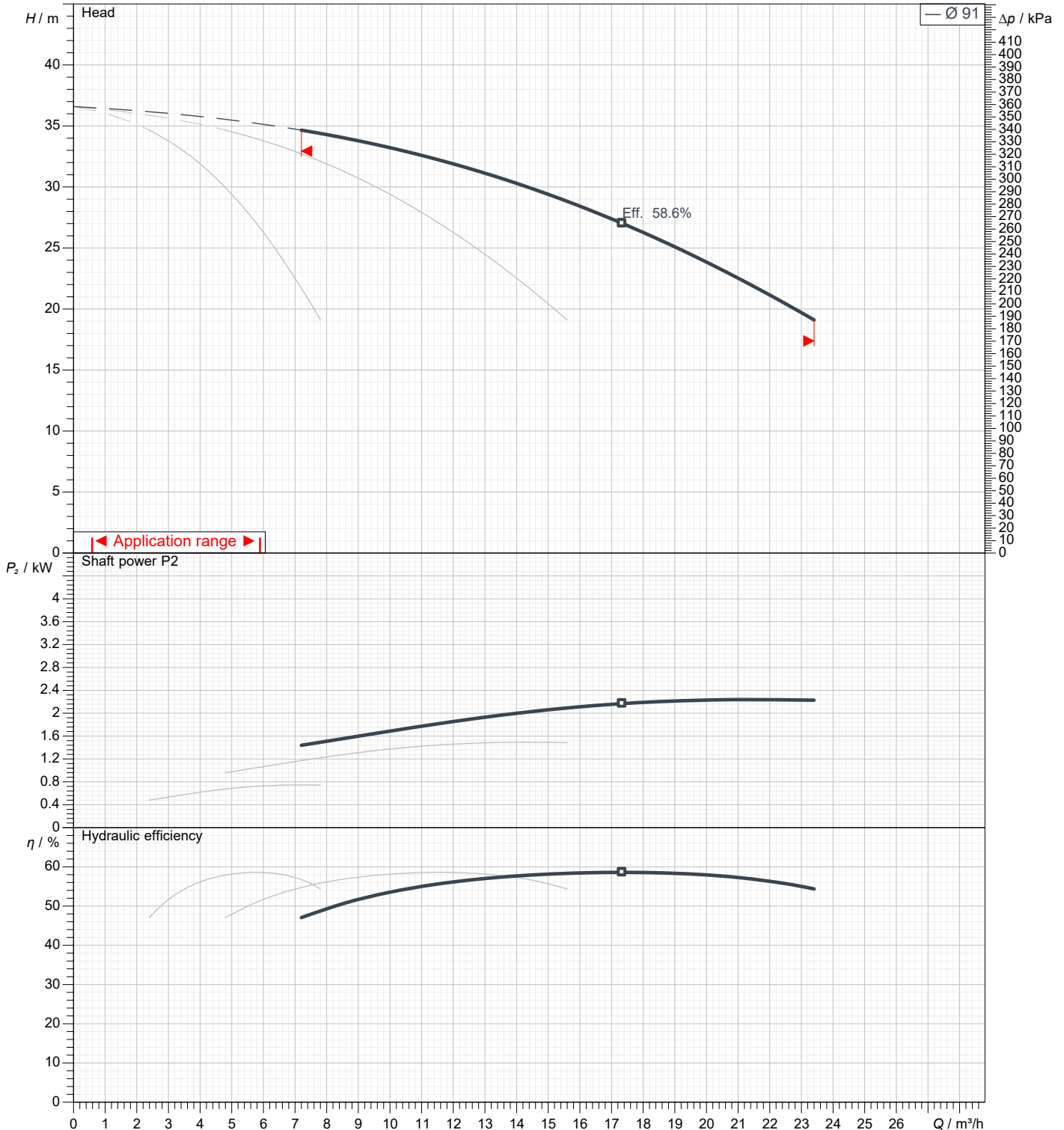

Dimensions

Booster set name

3GPE EVMSG5 4N5/0,75 ESPM

Customer	Date 09.06.2024	Company
Contact	Item no.	Issued by
Phone	Project	Phone
E-mail	Project ID	E-mail

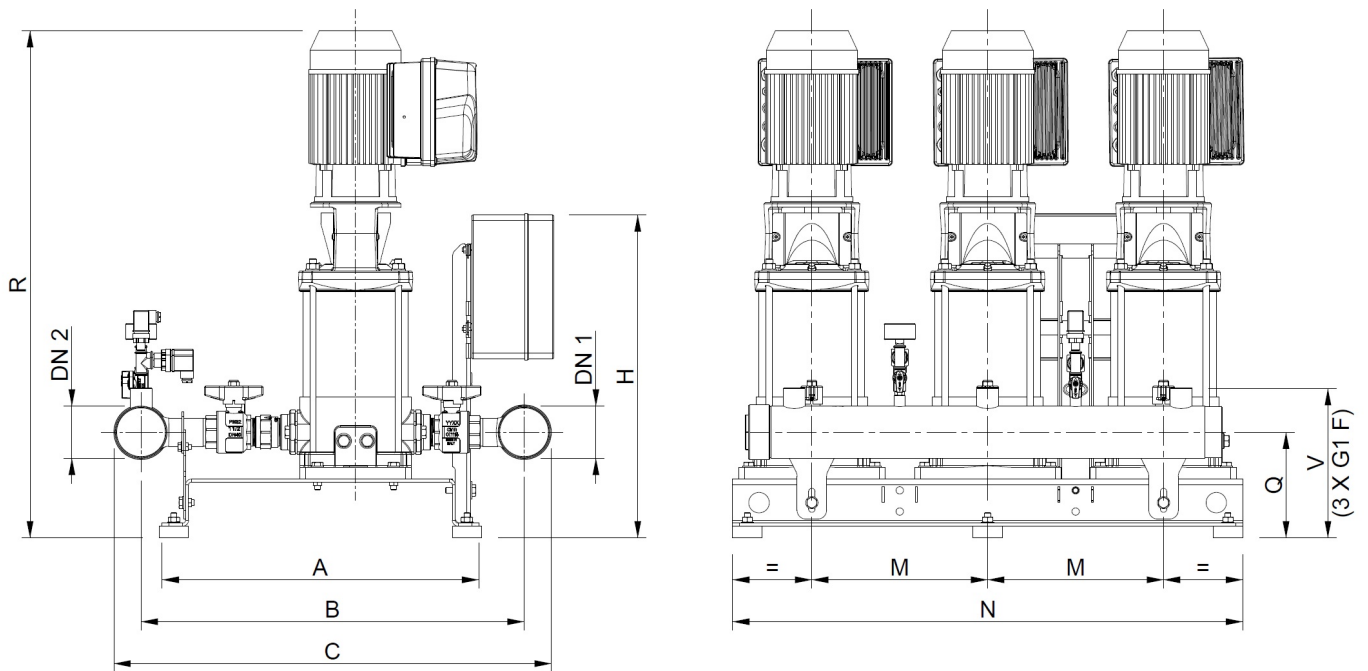

Dimensions in		mm						
1	A	380						
2	B	580						
3	C	630						
4	DN1	G2 1/2						
5	DN2	G2 1/2						
6	H	535						
7	M	300						
8	N	850						
9	Q	150						
10	R	663						
11	V	220						
12	Weight kg	111						
13								
14								
15								

(1/2) Construction

Booster set name

3GPE EVMSG5 4N5/0,75 ESPM

Customer	Date 09.06.2024	Company
Contact	Item no.	Issued by
Phone	Project	Phone
E-mail	Project ID	E-mail

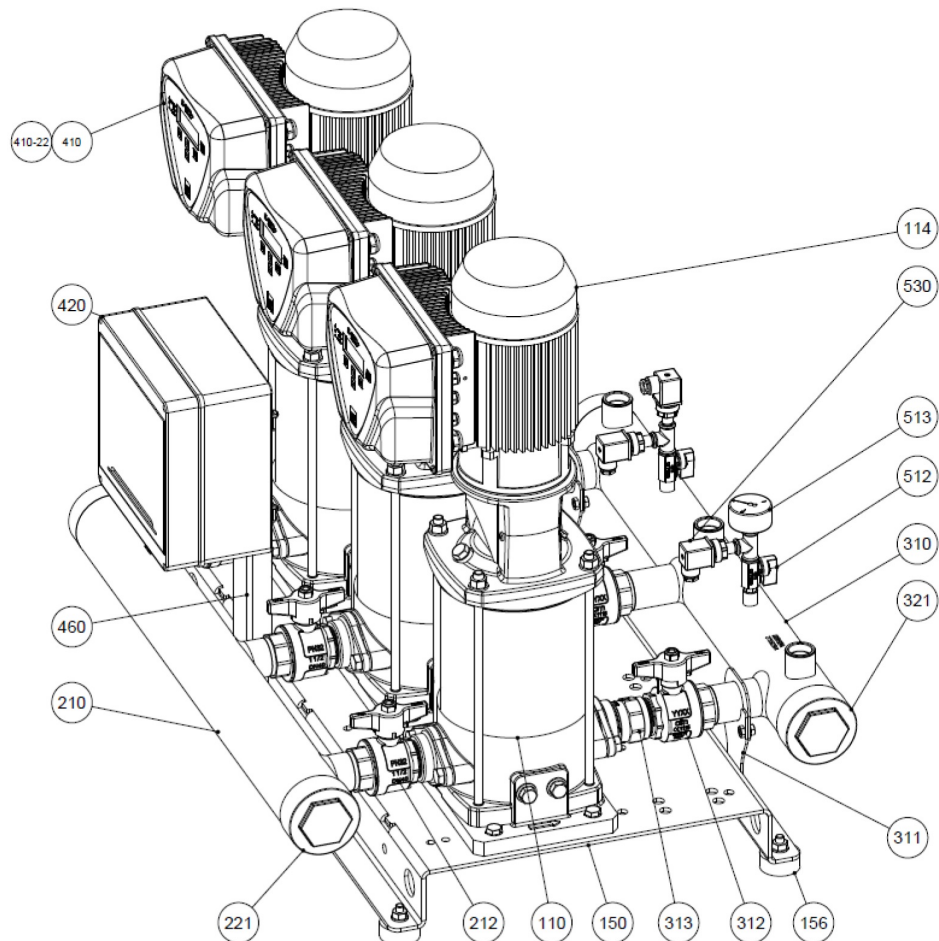

N°	PART NAME	MATERIAL	Quantity
110	Principal pump	-	3
114	Electric motor	-	3
150	Baseplate	Galvanized steel	1
156	Baseplate foot	SBR	6
210	Suction manifold	AISI 304	1
211	Manifold bracket	Galvanized steel	2
212	Ball valve	Brass / P.T.F.E.	3
221	Threaded female cap	AISI 304	1
310	Discharge manifold	AISI 304	1
311	Manifold bracket	Galvanized steel	2
312	Ball valve	Brass / P.T.F.E.	3
313	Check valve	Brass / NBR	3
321	Threaded female cap	AISI 304	1
410	E-SPD+	-	3
410-22	E-SPD+ adaptor	-	3
420	Protection panel	-	1
460	Protection panel frame	Galvanized steel	1
512	Ball valve	Brass / P.T.F.E.	2
513	Pressure gauge	Copper alloy / plastic	1
530	Pressure transmitter	-	3

(2/2) Construction

Booster set name

3GPE EVMSG5 4N5/0,75 ESPM

Customer	Date 09.06.2024	Company
Contact	Item no.	Issued by
Phone	Project	Phone
E-mail	Project ID	E-mail

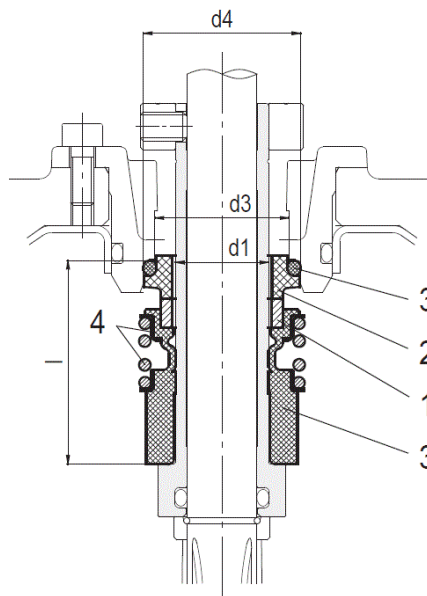

up to 16 bar
Cartridge Unbalanced type

Type key	Availability	Max operating pressure	Max operating temperature	Shaft seal type		Shaft seal material								
				Cartridge		1		2		3		4		5
				Type	Code	Rotating part	Code	Stationary part	Code	Elastomers	Code	Compression spring	Collar	Code
Q1BEG	●	16 bar	- 30°C to + 120°C	Unbalanced	(-)	SiC	(Q1)	Carbon	(B)	EPDM	(E)	AISI 316		(G)

Pump model	Shaft seal type		Max operating pressure	d1 [mm]	d2 [mm]	d3 [mm]	d4 [mm]	l [mm]
EVMS 1/3/5	Cartridge	Unbalanced	16 bar	16	-	23	27	35
		Balanced	25 bar		20			42.5
EVMS 10/15/20	Cartridge	Unbalanced	16 bar	20	-	29	35	37.5
		Balanced	25 bar		24			45