

# Technical Data

Booster set name

3GPE MATRIX 18-2T/1,5 ESPT (UK)

Customer	Date	09.06.2024	Company
Contact	Item no.		Issued by
Phone	Project		Phone
E-mail	Project ID		E-mail

## Requested data

1	Pump type	Booster Set	Fluid	Water
2	Number of pumps	3	Liquid temperature	°C 20
3	Flow	m <sup>3</sup> /h	Kin. viscosity	cSt 1.005
4	Head	m	Vapour pressure	kPa 2.34
5	Geodetic head	m	PH value	
6	Inlet pressure	kPa 0	Density	kg/m <sup>3</sup> 998.3
7	Available system NPSH	Ask our technical department.	Solids	Weight % 0
8	Ambient temperature	°C 20	Installation height	m 100

## Booster Set

9	Booster set name	3GPE MATRIX 18-2T/1,5 ESPT (UK)	Frequency	Hz 50	
10	Design	Booster Set			
11	Manufacturer	EBARA	Impeller Dia.	Max.	mm 107
12	Speed	rpm 2875		Designed	mm 107
13	No. of Stage	2		Min.	mm 107
14	Connection	Suction side UNI ISO 228 PN16	Flow	Operating	m <sup>3</sup> /h
15	Connection	Discharge side UNI ISO 228 PN16		Max-	m <sup>3</sup> /h 27
16	Max Working Pressure	kPa 1000		Min-	m <sup>3</sup> /h 7.8
17	Shut-off head	kPa 236.96	Head	Operating	m
18	Total weight	kg See the table of "Dimensions".		- (Qmax.)	m 5.2
19	Shaft power	kW		- (Qmin.)	m 22.0
20			Max. Shaft Power at max. impeller	kW 1.21	
21	Required NPSH	m	Efficiency	%	

## Materials

22	Frame	Galvanized steel	External pump casing	AISI 304
23	Manifold	AISI 304	Shaft	AISI 304
24	Check valve	Brass / NBR	Shaft seal	Ceramic/Carbon/EPDM
25	Ball valve	Brass / PTFE	O-ring	EPDM
26	Impeller	AISI 304		
27	Casing	AISI 304		

## Motor

28	Manufacturer	EPE Standard	Insulation class	F
29	Type	TEFC_MATRIX 18-2T/1.5_400_Three Phase	Phases	3~
30	Specific design	IE3 / 50 Hz / Pole pairs 1	Frame size	
31	Rated power	kW 1.5	Weight; motor	kg
32	Number of poles	2	Electric voltage	V 400
33	Speed	rpm 2850	Electric current	A 3.8
34	Degree of protection	IP 55		
35				

## Remarks

Item intended for the UK market only.

# Performance curve

Booster set name

3GPE MATRIX 18-2T/1,5 ESPT (UK)

Customer	Date	09.06.2024	Company
Contact	Item no.		Issued by
Phone	Project		Phone
E-mail	Project ID		E-mail

**Requested data**

1	Flow	m³/h	
2	Head	m	
3	Geodetic head	m	

**Booster set**

Operating flow	m³/h		Frequency	Hz	50
Operating head	m		Number of poles		2
Impeller Diameter Designed	mm	107	Speed	rpm	2875

Test standard: ISO 9906:2012 - Grade3B

Water; 20°C; 998.3kg/m³; 1cSt

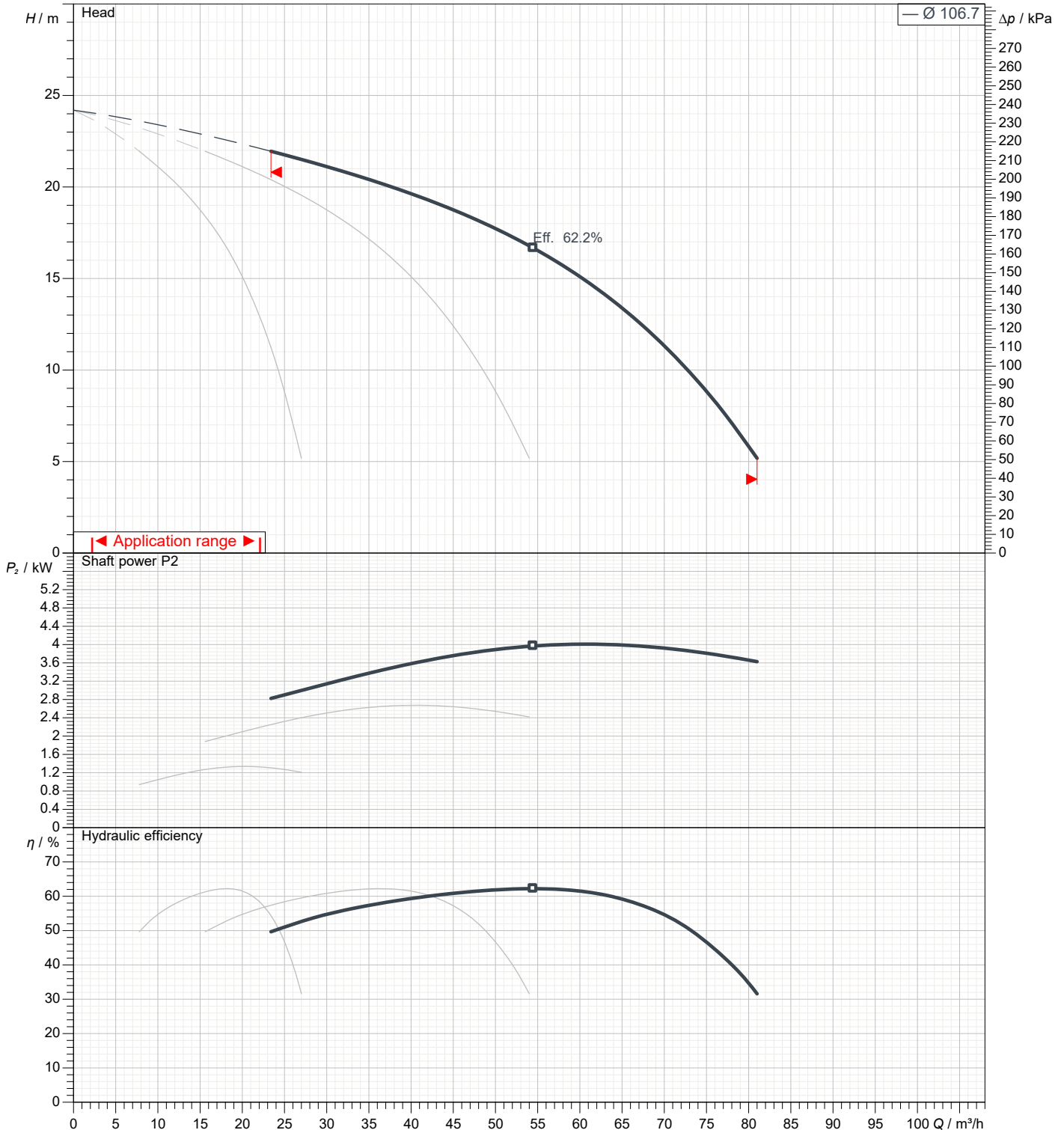

# Dimensions

Booster set name

3GPE MATRIX 18-2T/1,5 ESPT (UK)

Customer	Date 09.06.2024	Company
Contact	Item no.	Issued by
Phone	Project	Phone
E-mail	Project ID	E-mail

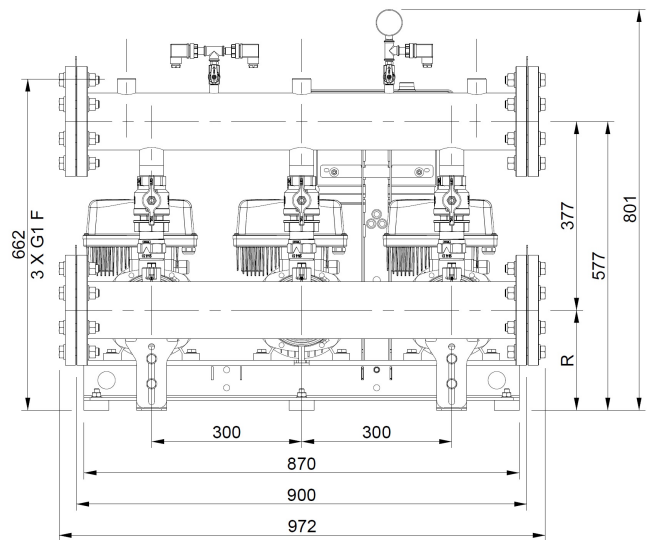
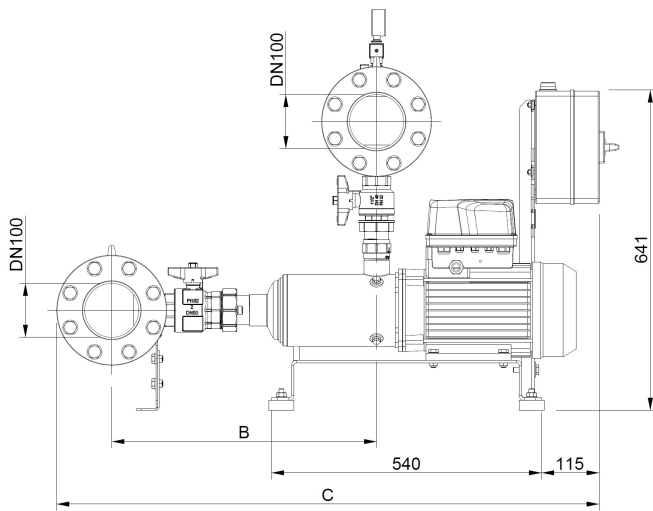

Dimensions in		mm						
1	B	420						
2	C	970						
3	Weight kg	150						
4								
5								
6								
7								
8								
9								
10								
11								
12								
13								
14								
15								

# (1/2) Construction

Booster set name

3GPE MATRIX 18-2T/1,5 ESPT (UK)

Customer	Date 09.06.2024	Company
Contact	Item no.	Issued by
Phone	Project	Phone
E-mail	Project ID	E-mail

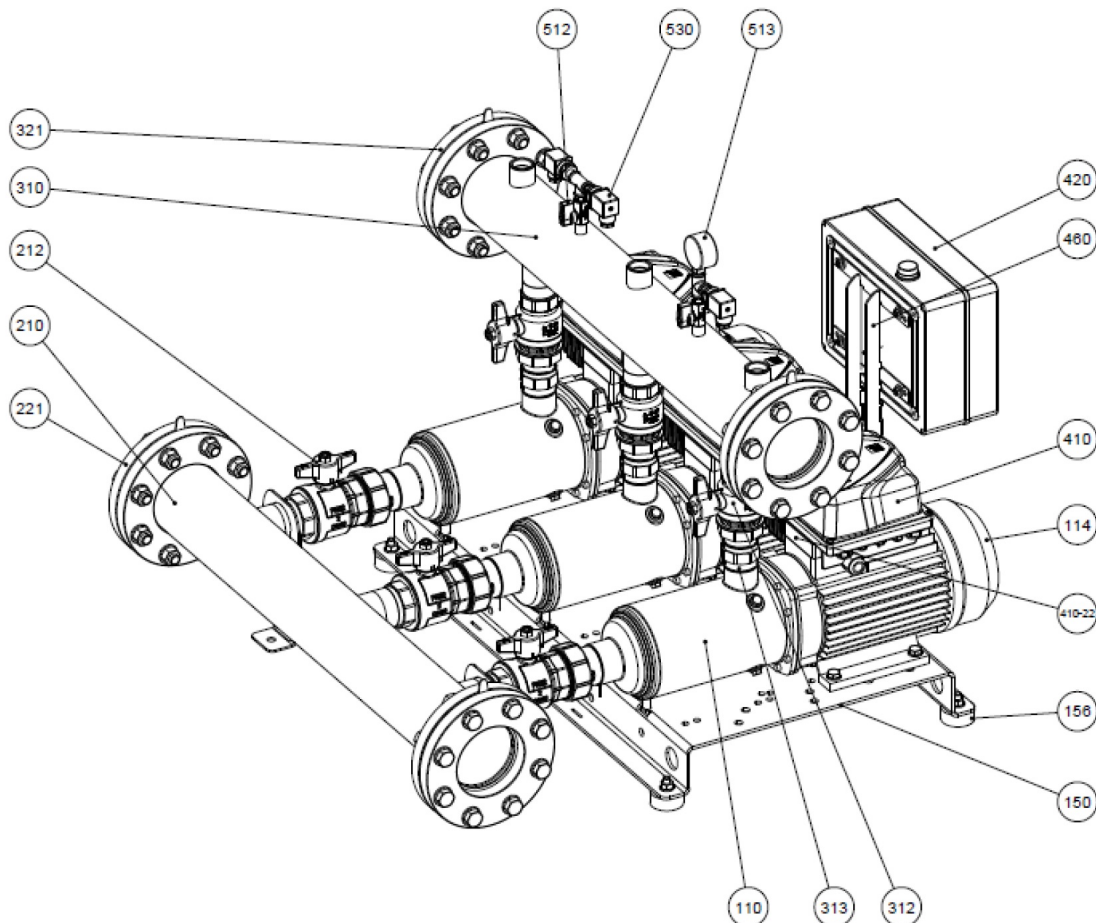

N°	PART NAME	MATERIAL	Quantity
110	Principal pump	-	3
114	Electric motor	-	3
150	Baseplate	Galvanized steel	1
156	Baseplate foot	SBR	6
210	Suction manifold	AISI 304	1
212	Union ball valve	Brass / P.T.F.E.	3
221	Threaded female cap	AISI 304	1
310	Discharge manifold	AISI 304	1
312	Union ball valve	Brass / P.T.F.E.	3
313	Check valve	Brass / NBR	3
321	Threaded female cap	AISI 304	1
410	E-SPD+	-	3
410-22	E-SPD+ adaptor	-	3
420	Protection panel	-	1
460	Protection panel frame	Galvanized steel	1
512	Ball valve	Brass / P.T.F.E.	2
513	Pressure gauge	Copper alloy / plastic	1
530	Pressure transmitter	-	3

**(2/2)**  
**Construction**

**Booster set name**  
**3GPE MATRIX 18-2T/1,5 ESPT (UK)**

Customer	Date 09.06.2024	Company
Contact	Item no.	Issued by
Phone	Project	Phone
E-mail	Project ID	E-mail

**MECHANICAL SEAL**



STANDARD*	A	B	C	Material	E	F	G
	Rotary seal ring	Stationary seal ring	Gasket	D Bellows	Spring	Frame	Retainer ring
	Carbon	Ceramic	EPDM	EPDM	EN 1.4402 (AISI 316)	EN 1.4402 (AISI 316)	EN 1.4402 (AISI 316)

\*Approval for drinking water application  
WRAS Approval product

