

Technical Data

Pump Name

3LM4 50-125/0.55

Customer	Date	09.06.2024	Company
Contact	Item no.		Issued by
Phone	Project		Phone
E-mail	Project ID		E-mail

Requested data

1	Pump type	CENTRIFUGAL PUMPS	Fluid	Water
2	Number of pumps / Reserve	1 / 0	Liquid temperature	°C
3	Flow	m³/h	Kin. viscosity	cSt
4	Head	m	Vapour pressure	kPa
5	Geodetic head	m	PH value	
6	Inlet pressure (pin)	kPa	Density	kg/m³
7	Available system NPSH		Solids	Weight %
8	Ambient temperature	°C		

Pump

9	Pump Name	3LM4 50-125/0.55	Frequency	Hz	50	
10	Design	CENTRIFUGAL PUMPS	Installation type		STANDARD	
11	Manufacturer	EBARA	Impeller Diameter	Max.	mm	
12	Speed	rpm		1400	Designed	mm
13	No. of Stage	1		Min.	mm	140
14	Connection	Suction side	DIN 2532	Flow	Operating	m³/h
15	Connection	Discharge side	DIN 2532		Max-	m³/h
16	Max Working Pressure	kPa	1000		Min-	m³/h
17	Shut-off head	kPa	62.67	Head	Operating	m
18	Total weight	kg	See the table of "Dimensions".		- (Qmax.)	m
19	Shaft power	kW			- (Qmin.)	m
20			Max. Shaft Power at max. impeller	kW	0.49	
21	Required pump NPSH	m	Efficiency	%		

Materials

22	Impeller	AISI 316L		
23	Casing	AISI 316L		
24	Shaft	AISI 316L		
25				
26				
27				

Motor

28	Manufacturer	EPE Standard	Insulation class	F	
29	Type	TEFC_3M450-125/0.55_230_Three Phase	Phases	3~	
30	Specific design	- / 50 Hz / Pole pairs 2	Frame size	90	
31	Rated power	kW	0.55	Weight	kg
32	Number of poles	4	Electric voltage	V	230
33	Speed	rpm	1400	Electric current	A
34	Degree of protection	IP 55			
35					

Remarks

Performance Curve

Pump Name

3LM4 50-125/0.55

Customer	Date	09.06.2024	Company
Contact	Item no.		Issued by
Phone	Project		Phone
E-mail	Project ID		E-mail

Requested data

1	Flow	m³/h	
2	Head	m	
3	Geodetic head	m	

Pump

Operating flow	m³/h		Frequency	Hz	50
Operating head	m		Number of poles		4
Impeller diameter designed	mm	140	Speed	rpm	1400

Test standard: ISO 9906:2012 - Grade3B

Water; 20°C; 998.3kg/m³; 1cSt

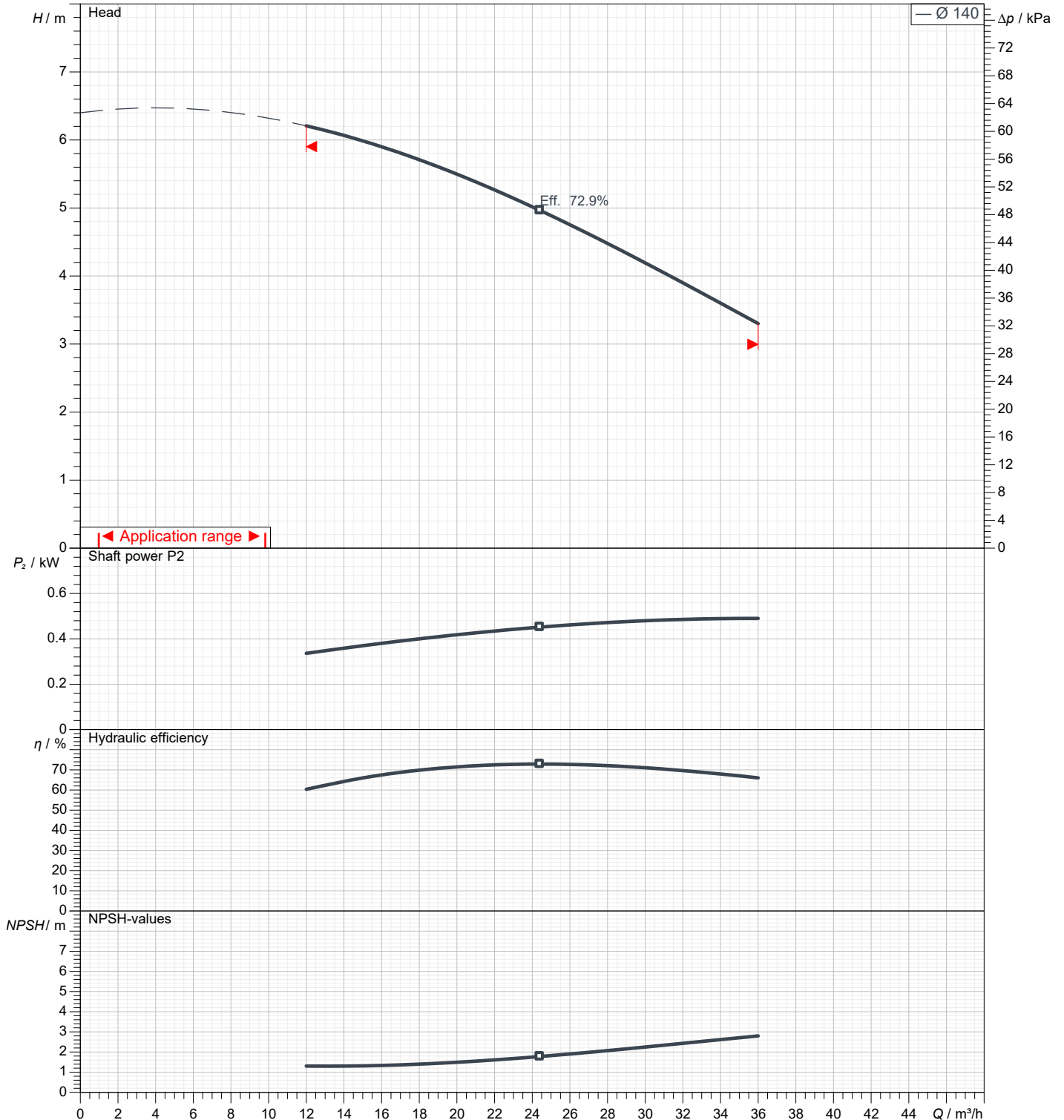

Dimensions

Pump Name 3LM4 50-125/0.55

Customer	Date 09.06.2024	Company
Contact	Item no.	Issued by
Phone	Project	Phone
E-mail	Project ID	E-mail

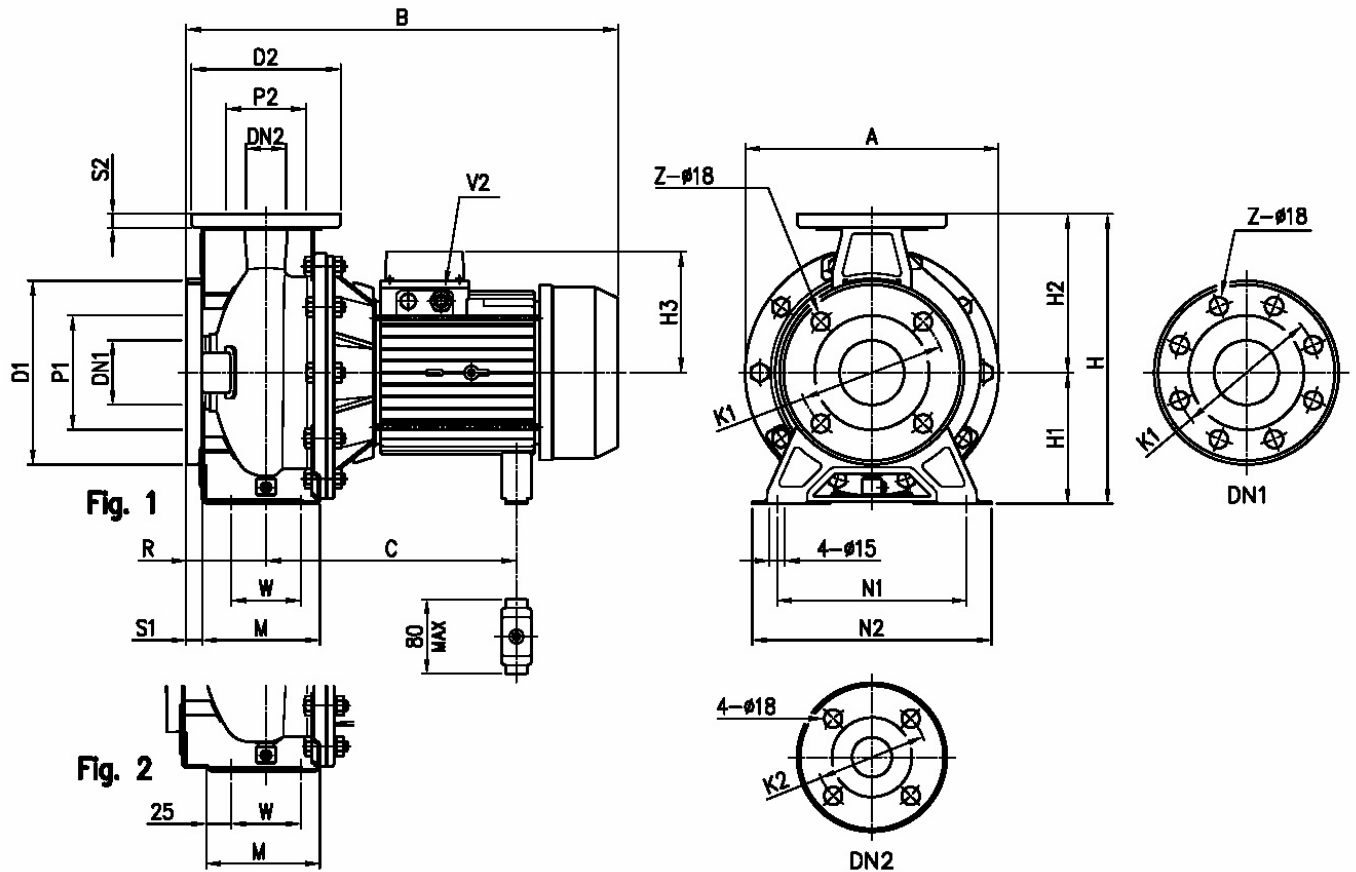

Dimensions in		mm						
1	A	254	H3	119				
2	B	413	M	114				
3	C	219	N1	190				
4	Dia D1	185	N2	240				
5	Dia D2	165	R	100				
6	Dia DN1	65	S1	16				
7	Dia DN2	50	S2	16				
8	Dia K1	145	V2	PG 11				
9	Dia K2	125	W	70				
10	Dia P1	115	Weight P&M	20,5 kg				
11	Dia P2	95	Z	4				
12	Fig	2						
13	H	292						
14	H1	132						
15	H2	160						

(1/3)

Construction

Pump Name 3LM4 50-125/0.55

Customer	Date 09.06.2024	Company
Contact	Item no.	Issued by
Phone	Project	Phone
E-mail	Project ID	E-mail

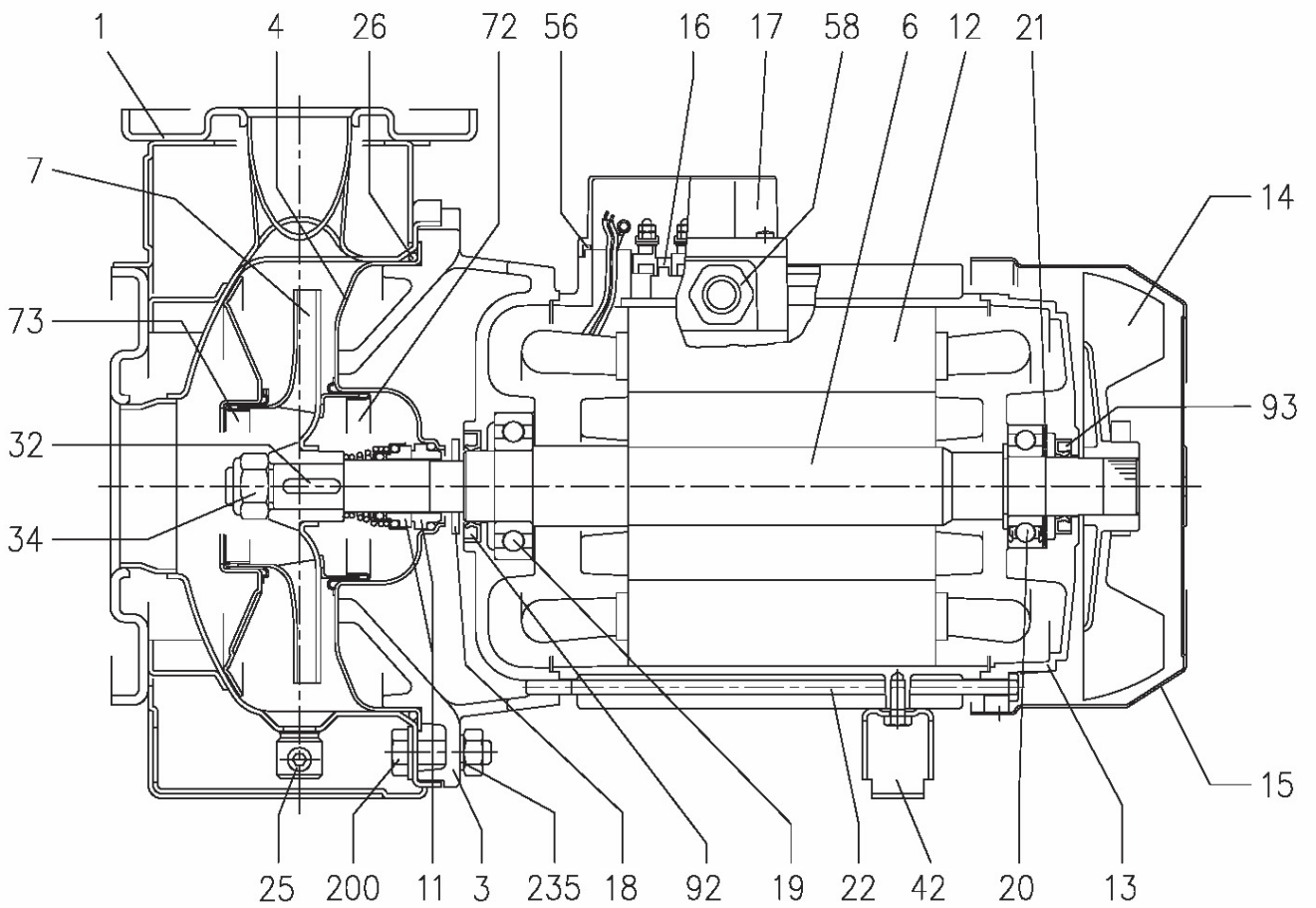

(2/3)

Construction

Pump Name 3LM4 50-125/0.55

Customer	Date 09.06.2024	Company
Contact	Item no.	Issued by
Phone	Project	Phone
E-mail	Project ID	E-mail

N°	PART NAME	MATERIAL		DIMENSIONS	STANDARD	Q.TY
		3M4	3LM4			
1	Casing	EN 1.4301 (AISI 304)	EN 1.4404 (AISI 316L)			1
3	Motor bracket	[5]				1
4	Casing cover	EN 1.4301 (AISI 304)	EN 1.4404 (AISI 316L)			1
6	Shaft with rotor-Part in contact with liquid	EN 1.4301 (AISI 304)	EN 1.4404 (AISI 316L)			1
7	Impeller 32, 40, 50 65-125/160/200	EN 1.4301 (AISI 304)	EN 1.4404 (AISI 316L)			1
		EN 1.4401 (AISI 316)				
11	Mechanical seal [3]	Carbon/Ceramic/NBR	SiC/SiC/FPM			1
12	Motor frame with stator	-				1
13	Motor cover	Aluminium				1
14	Fan	PA				1
15	Fan cover	Fe P04 Galvanized				1
16	Terminal	-				1
17	Terminal box cover	Aluminium (three phase version)				1
18	Splash ring	NBR	/	40x21.5x3	EBARA DRAWING	1
19	Bearing	-				1
20	Bearing	-				1
21	Adjusting ring	Steel C70				1
22	Tie rod	Fe 42 Galvanized		M5	EBARA DRAWING	4
25	Draing plug	EN 1.4401 (AISI 316) / PTFE		R 1/8" L=8	DIN 906	1
26	O ring 32-125, 40-125 32-160, 40-160, 50-125, 65-160 32-200, 40-200,50-160, 50-200, 65-160, 65-200	NBR [4]	FPM	158.11x5.34	OR 6625	1
				183.52x5.34	OR 6720	
				227.96x5.34	OR 6895	
32	Key	EN 1.4401 (AISI 316)		6x6x25	UNI 6604	1
34	Impeller nut Other models 50-200/2.2	EN 1.4301 (AISI 304)	EN 1.4404 (AISI 316L)	M16x1.5	UNI 7474	1
				M18x1.5		
42	Foot	Aluminium / Galvanized steel			EBARA DRAWING	1
56	Box gasket	NBR				1
58	Fasting nut	-				1
72	Casing ring (not for 65 version) [1]	EN 1.4301 (AISI 304)	EN 1.4404 (AISI 316L)			1
73	Casing ring (not for 65 version)	EN 1.4301 (AISI 304)	EN 1.4404 (AISI 316L)			1
92	O ring Up to 1.5kW From 2.2kW to 3kW	-	-	25x40x7	DIN 3760 without spring	1
				30x47X7		
93	O ring For 0.25kW For 0.37kW and 0.55kW From 0.75 kW to 3kW	-	-	15x30x5	DIN 3760 without spring	1
				17x32X7		
				25x40x7		
200	Screw 32-125, 40-125 40-160, 40-200, 50-125, 50-160, 50-200, 65-125, 65-160, 65-200	Stainless steel A2 70 class ISO 3506/1		M 8x30	UNI 5739	8
				M 10x35		[2]
235	Washer 32-125, 40-125 40-160, 40-200, 50-125, 50-160, 50-200, 65-125, 65-160, 65-200	EN 1.4301 (AISI 304)		8.4x17	UNI 6592	8
				10.5x21		[2]

[1] For version 32-200, 40-200, 50-160 , 50-200

[2] Quantity = 10 for 32-160, 40-160, 50-125, 65-125
Quantity = 12 for 32-200, 40-200, 50-160, 50-200, 65-160, 65-200

[3] Special version: see CONSTRUCTION 3

[4] FPM for H-HS-HW-HSW version

EPDM for E version, Q1AEGG, U3U3EGG, Q1Q1EGG, Q1U3EGG, U3CEGG

[5] Cast iron EN-GJL-200-EN 1561 for 32-200/3 and models with 15, 18.5, 22 kW motor
Aluminum AL-EN-1706-AC-46000-D for all the others

(3/3)

Construction

Pump Name 3LM4 50-125/0.55

Customer	Date 09.06.2024	Company
Contact	Item no.	Issued by
Phone	Project	Phone
E-mail	Project ID	E-mail

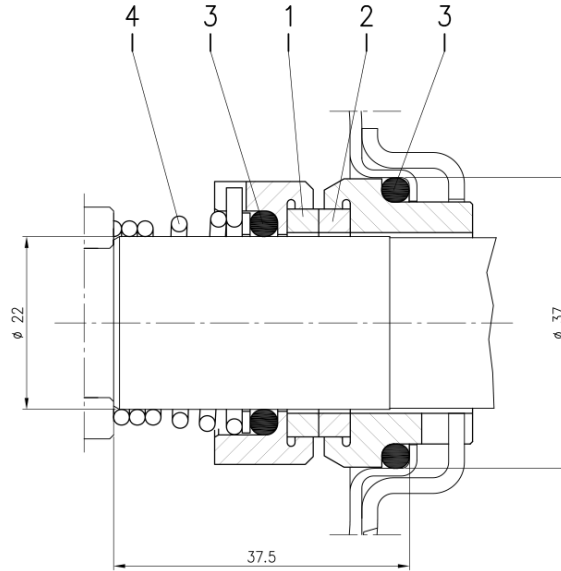

Version	Pump type	Material			
		1 Stationary seal ring	2 Rotary seal ring	3 Rubber	4 Frame + spring
L ø22	32-125/160/200 40-125/160/200 50-125/160/200 65-125/160/200 80-160	SiC	SiC	FPM	EN 1.4571 (AISI 316Ti)