

Technical Data

Pump Name

3LM 40-125/1.5

Customer	Date	09.06.2024	Company
Contact	Item no.		Issued by
Phone	Project		Phone
E-mail	Project ID		E-mail

Requested data

1	Pump type	CENTRIFUGAL PUMPS	Fluid	Water
2	Number of pumps / Reserve	1 / 0	Liquid temperature	°C 20
3	Flow m³/h		Kin. viscosity	cSt 1.005
4	Head m		Vapour pressure	kPa 2.34
5	Geodetic head m		PH value	
6	Inlet pressure (pin) kPa	0	Density	kg/m³ 998.3
7	Available system NPSH		Solids	Weight % 0
8	Ambient temperature °C	20		

Pump

9	Pump Name	3LM 40-125/1.5	Frequency	Hz 50
10	Design	CENTRIFUGAL PUMPS	Installation type	STANDARD
11	Manufacturer	EBARA	Impeller Diameter	Max. mm 125
12	Speed rpm	2900		Designed mm 125
13	No. of Stage	1		Min. mm 125
14	Connection Suction side	DIN 2532	Flow	Operating m³/h
15	Connection Discharge side	DIN 2532		Max- m³/h 42
16	Max Working Pressure kPa	1000		Min- m³/h 12
17	Shut-off head kPa	195.87	Head	Operating m
18	Total weight kg	See the table of "Dimensions".		- (Qmax.) m 7.0
19	Shaft power kW			- (Qmin.) m 19.0
20			Max. Shaft Power at max. impeller	kW 1.40
21	Required pump NPSH m		Efficiency	%

Materials

22	Impeller	AISI 316L		
23	Casing	AISI 316L		
24	Shaft	AISI 316L		
25				
26				
27				

Motor

28	Manufacturer	EPE Standard	Insulation class	F
29	Type	TEFC_3M40-125/1.5_230_Three Phase	Phases	3~
30	Specific design	IE3 / 50 Hz / Pole pairs 1	Frame size	
31	Rated power kW	1.5	Weight	kg
32	Number of poles	2	Electric voltage	V 230
33	Speed rpm	2900	Electric current	A 5.8
34	Degree of protection	IP 55		
35				

Remarks

Performance Curve

Pump Name

3LM 40-125/1.5

Customer	Date	09.06.2024	Company
Contact	Item no.		Issued by
Phone	Project		Phone
E-mail	Project ID		E-mail

Requested data

1	Flow	m³/h	
2	Head	m	
3	Geodetic head	m	

Pump

Operating flow	m³/h		Frequency	Hz	50
Operating head	m		Number of poles		2
Impeller diameter designed	mm	125	Speed	rpm	2900

Test standard: ISO 9906:2012 - Grade3B

Water; 20°C; 998.3kg/m³; 1cSt

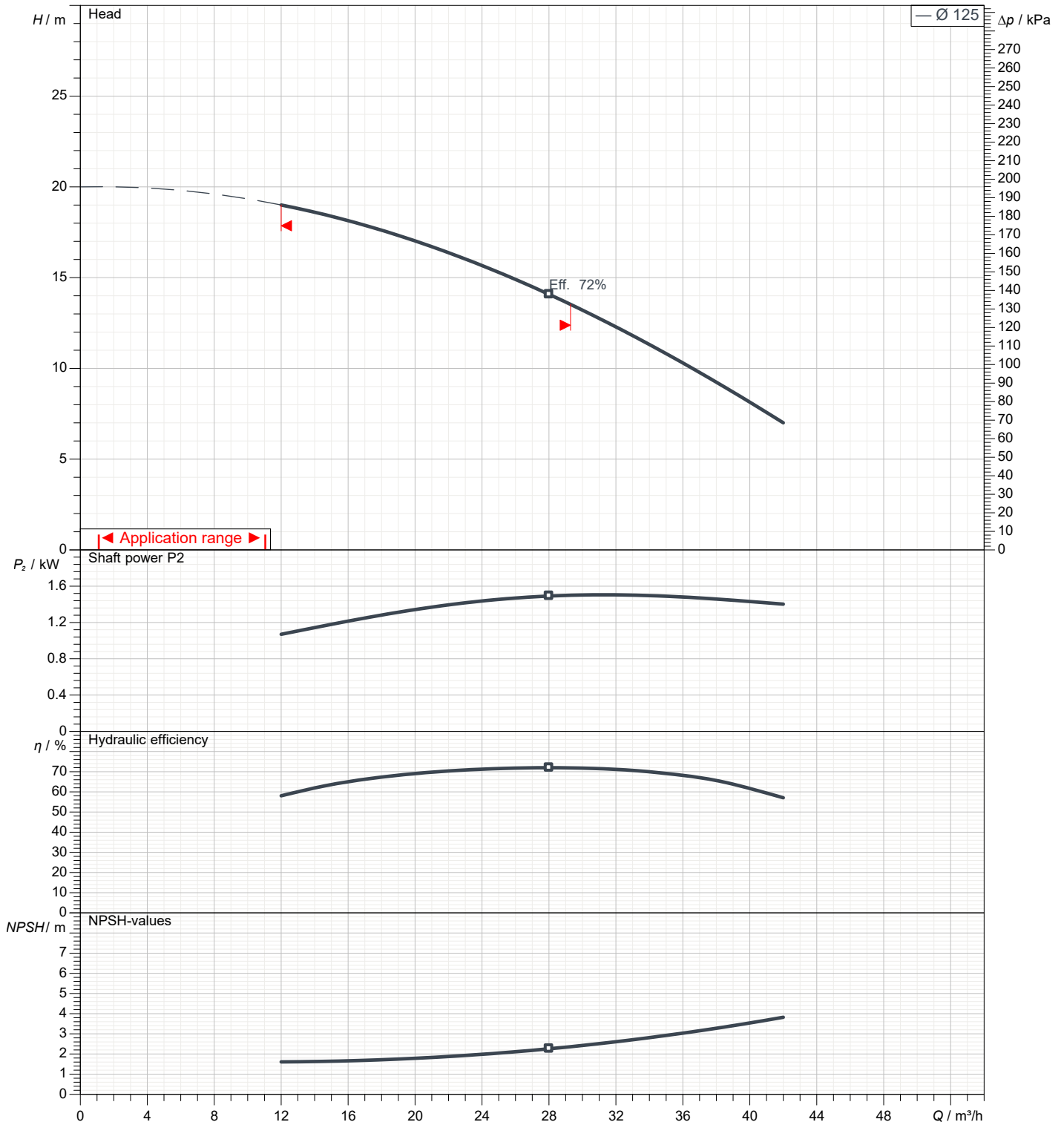

Dimensions

Pump Name 3LM 40-125/1.5

Customer	Date 09.06.2024	Company
Contact	Item no.	Issued by
Phone	Project	Phone
E-mail	Project ID	E-mail

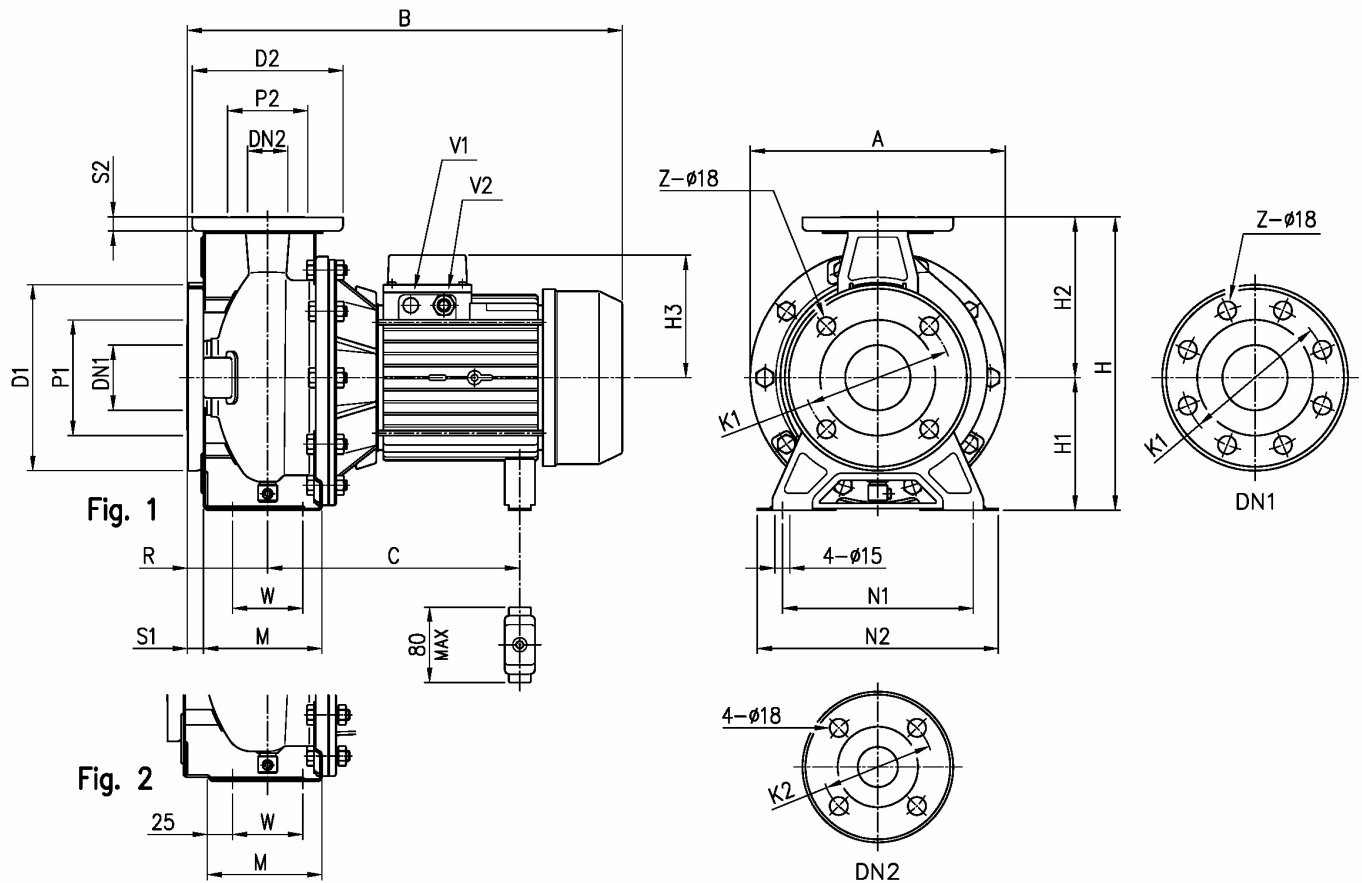

Dimensions in		mm						
1	A	213	H3	119				
2	B	431	M	114				
3	C	232	N1	160				
4	Dia D1	185	N2	210				
5	Dia D2	150	R	80				
6	Dia DN1	65	S1	16				
7	Dia DN2	40	S2	14				
8	Dia K1	145	V2	[PG 13].5				
9	Dia K2	110	W	70				
10	Dia P1	115	Weight P&M	[24].6 kg				
11	Dia P2	80	Z	4				
12	Fig	1						
13	H	252						
14	H1	112						
15	H2	140						

(1/3)

Construction

Pump Name 3LM 40-125/1.5

Customer	Date 09.06.2024	Company
Contact	Item no.	Issued by
Phone	Project	Phone
E-mail	Project ID	E-mail

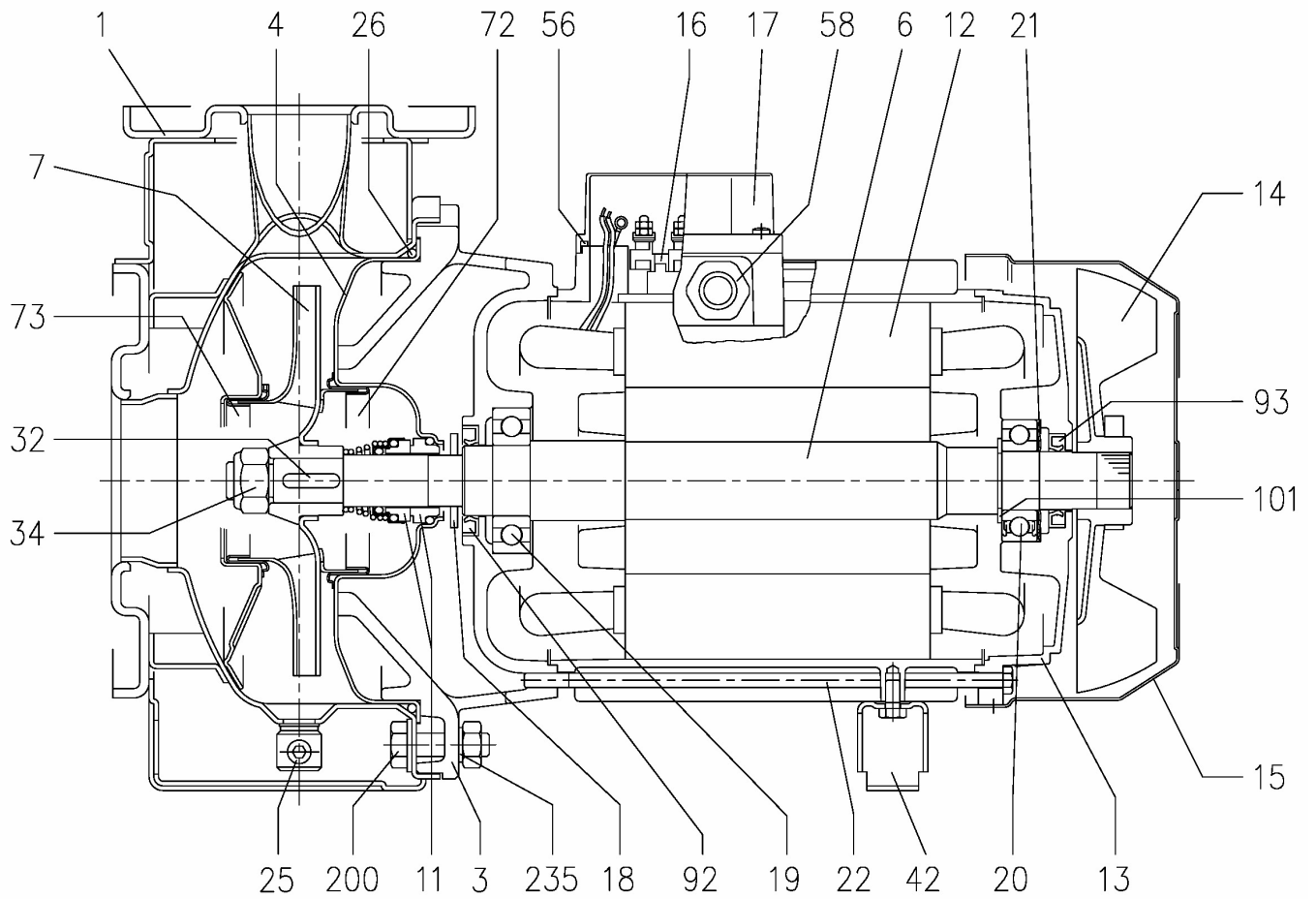

(2/3)

Construction

Pump Name 3LM 40-125/1.5

Customer	Date 09.06.2024	Company
Contact	Item no.	Issued by
Phone	Project	Phone
E-mail	Project ID	E-mail

(3/3)

Construction

Pump Name 3LM 40-125/1.5

Customer	Date 09.06.2024	Company
Contact	Item no.	Issued by
Phone	Project	Phone
E-mail	Project ID	E-mail

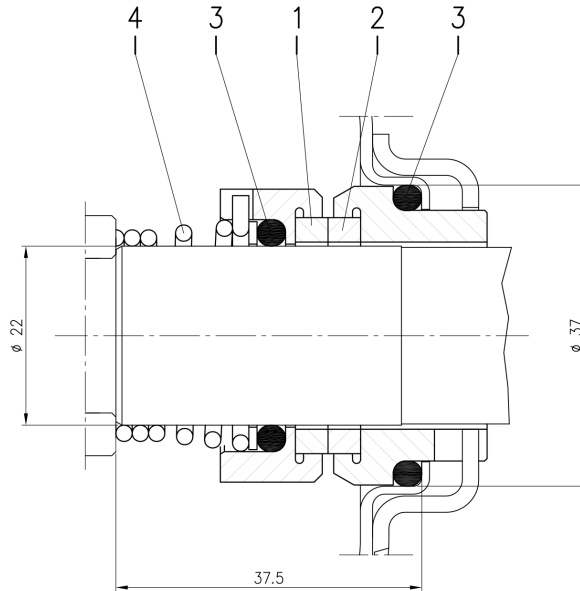

Version	Pump type	Material			
		1 Stationary seal ring	2 Rotary seal ring	3 Rubber	4 Frame + spring
L $\phi 22$	32-125/160/200 40-125/160/200 50-125/160/200 65-125 65-160/7.5-9.2-11	SiC	SiC	FPM	EN 1.4571 (AISI 316Ti)