

Technical Data

Pump Name

3LM 40-200/9.26 IE3

Customer	Date	2024-06-20	Company
Contact	Item no.		Issued by
Phone	Project		Phone
E-mail	Project ID	Proiect redenumit 2024-06-20 10:03:09	E-mail

Requested data

1	Pump type	CENTRIFUGAL PUMPS	Fluid	Water
2	Number of pumps / Reserve	1 / 0	Liquid temperature	°C 20
3	Flow m³/h		Kin. viscosity	mm²/s 1.005
4	Head m		Vapour pressure	bar 0.0234
5	Geodetic head m		PH value	
6	Inlet pressure (pin) bar	0	Density	kg/m³ 998.3
7	Available system NPSH		Solids	Weight % 0
8	Ambient temperature °C	20		

Pump

9	Pump Name	3LM 40-200/9.26 IE3	Frequency	Hz 60
10	Design	CENTRIFUGAL PUMPS	Installation type	STANDARD
11	Manufacturer	EBARA	Impeller Diameter	Max. mm 183
12	Speed rpm	3480		Designed mm 183
13	No. of Stage	1		Min. mm 183
14	Connection Suction side	DIN 2532	Flow	Operating m³/h
15	Connection Discharge side	DIN 2532		Max- m³/h 50
16	Max Working Pressure bar	10		Min- m³/h 12
17	Shut-off head bar	6.61	Head	Operating m
18	Total weight kg	See the table of "Dimensions".		- (Qmax.) m 48.0
19	Shaft power kW			- (Qmin.) m 66.7
20			Max. Shaft Power at max. impeller	kW 9.54
21	Required pump NPSH m		Efficiency	%

Materials

22	Impeller	AISI 316L		
23	Casing	AISI 316L		
24	Shaft	AISI 316L		
25				
26				
27				

Motor

28	Manufacturer	EPE Standard	Insulation class	F
29	Type	TEFC_3M 40-200/9.26_460_Three Phase	Phases	3~
30	Specific design	IE3 / 60 Hz / Pole pairs 1	Frame size	
31	Rated power kW	9.2	Weight	kg
32	Number of poles	2	Electric voltage	V 460
33	Speed rpm	3500	Electric current	A 15.1
34	Degree of protection	IP 55		
35				

Remarks

Performance Curve

Pump Name

3LM 40-200/9.26 IE3

Customer	Date	2024-06-20	Company
Contact	Item no.		Issued by
Phone	Project		Phone
E-mail	Project ID	Project redenumit 2024-06-20 10:03:09	E-mail

Requested data

1	Flow	m³/h	
2	Head	m	
3	Geodetic head	m	

Pump

Operating flow	m³/h		Frequency	Hz	60
Operating head	m		Number of poles		2
Impeller diameter designed	mm	183	Speed	rpm	3480

Test standard: ISO 9906:2012 - Grade3B

Water; 20°C; 998.3kg/m³; 1mm²/s

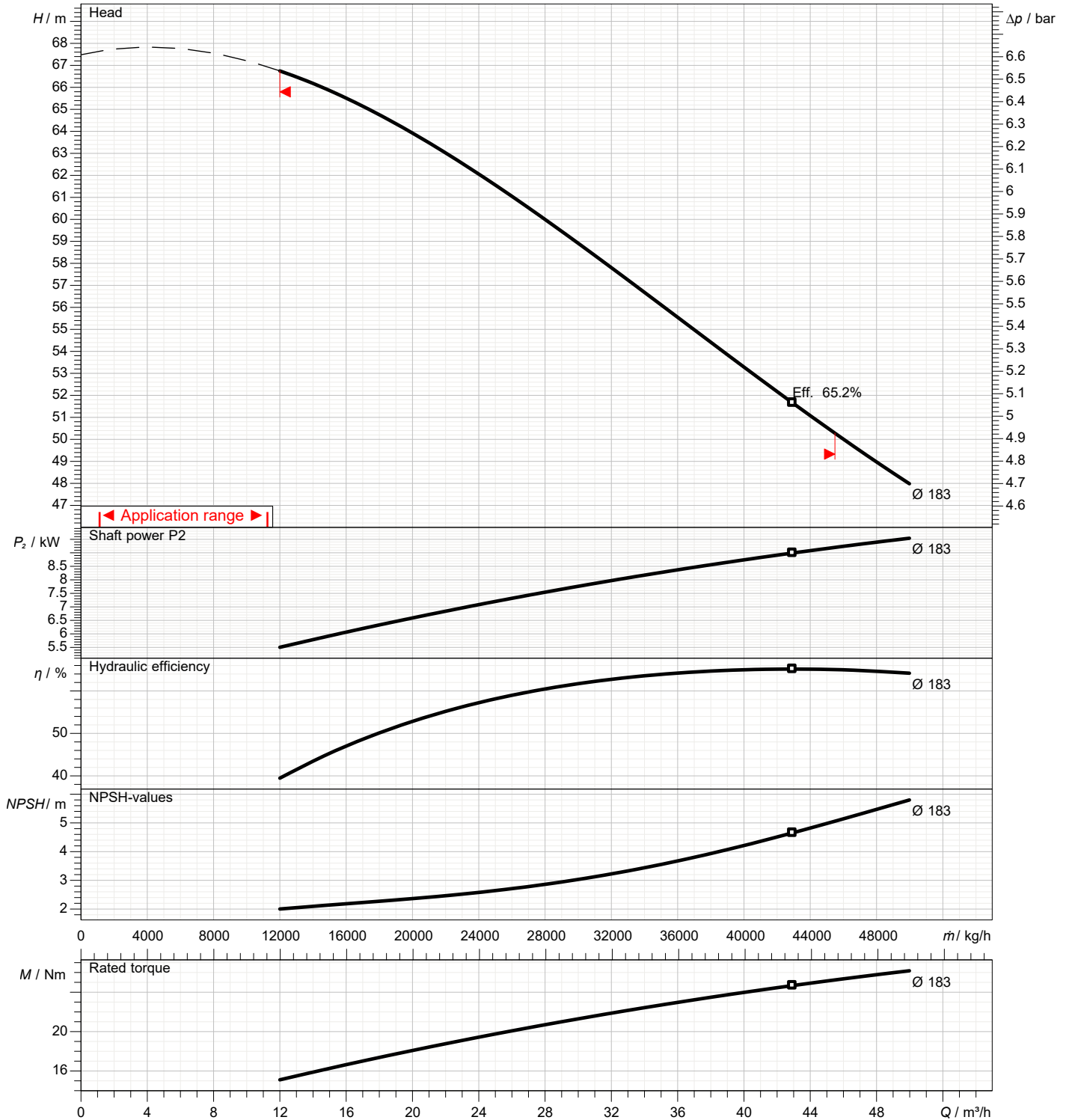

Dimensions

Pump Name 3LM 40-200/9.26 IE3

Customer	Date 2024-06-20	Company
Contact	Item no.	Issued by
Phone	Project	Phone
E-mail	Project ID Proiect redenumit 2024-06-20 10:03:09	E-mail

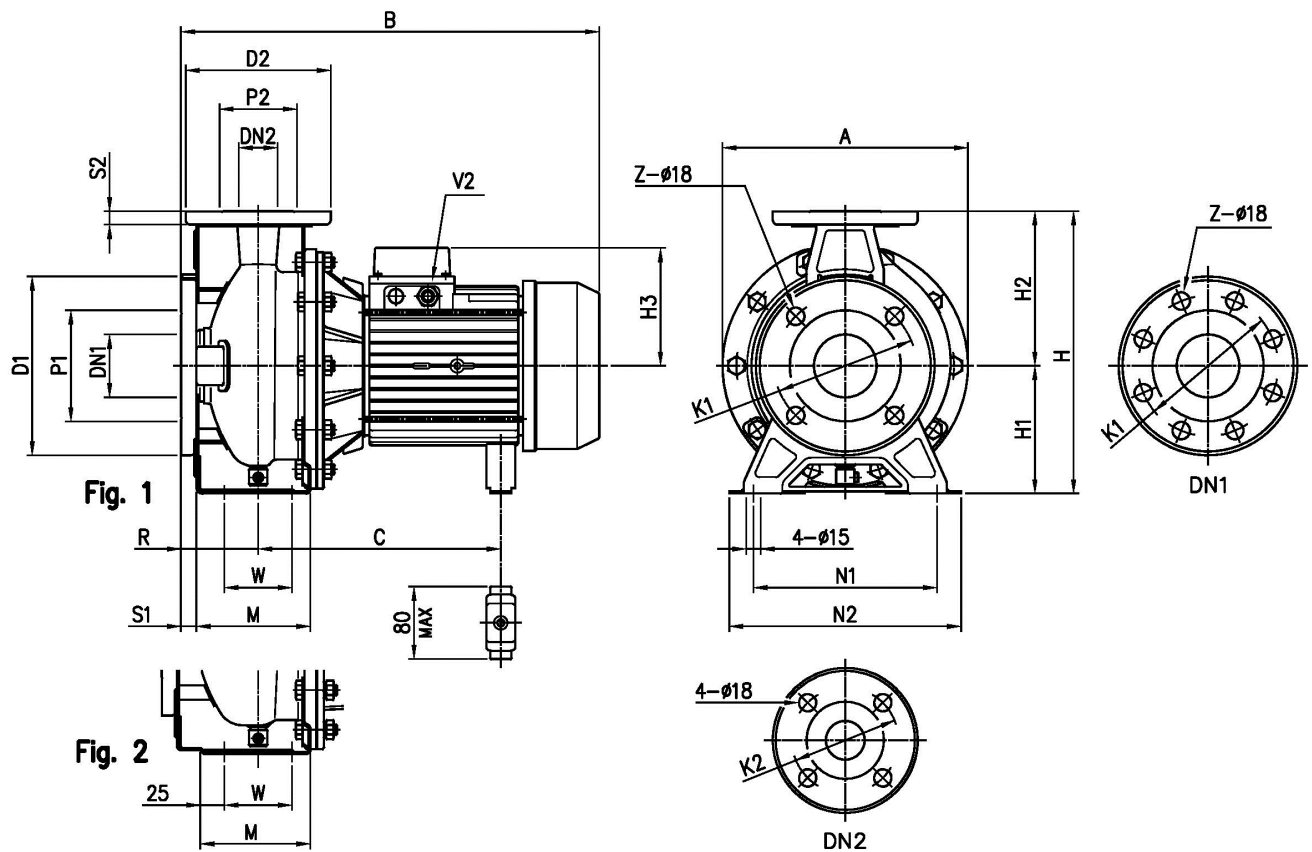

Dimensions in		mm						
1	A	296	H3	178				
2	B	595	M	115				
3	C	329	N1	212				
4	Dia D1	185	N2	265				
5	Dia D2	150	R	100				
6	Dia DN1	65	S1	16				
7	Dia DN2	40	S2	14				
8	Dia K1	145	V2	PG 21				
9	Dia K2	110	W	70				
10	Dia P1	115	Weight P&M	66,8 kg				
11	Dia P2	80	Z	4				
12	Fig	2						
13	H	340						
14	H1	160						
15	H2	180						

(1/3)

Construction

Pump Name 3LM 40-200/9.26 IE3

Customer	Date 2024-06-20	Company
Contact	Item no.	Issued by
Phone	Project	Phone
E-mail	Project ID Proiect redenumit 2024-06-20 10:03:09	E-mail

UP TO 11 kW

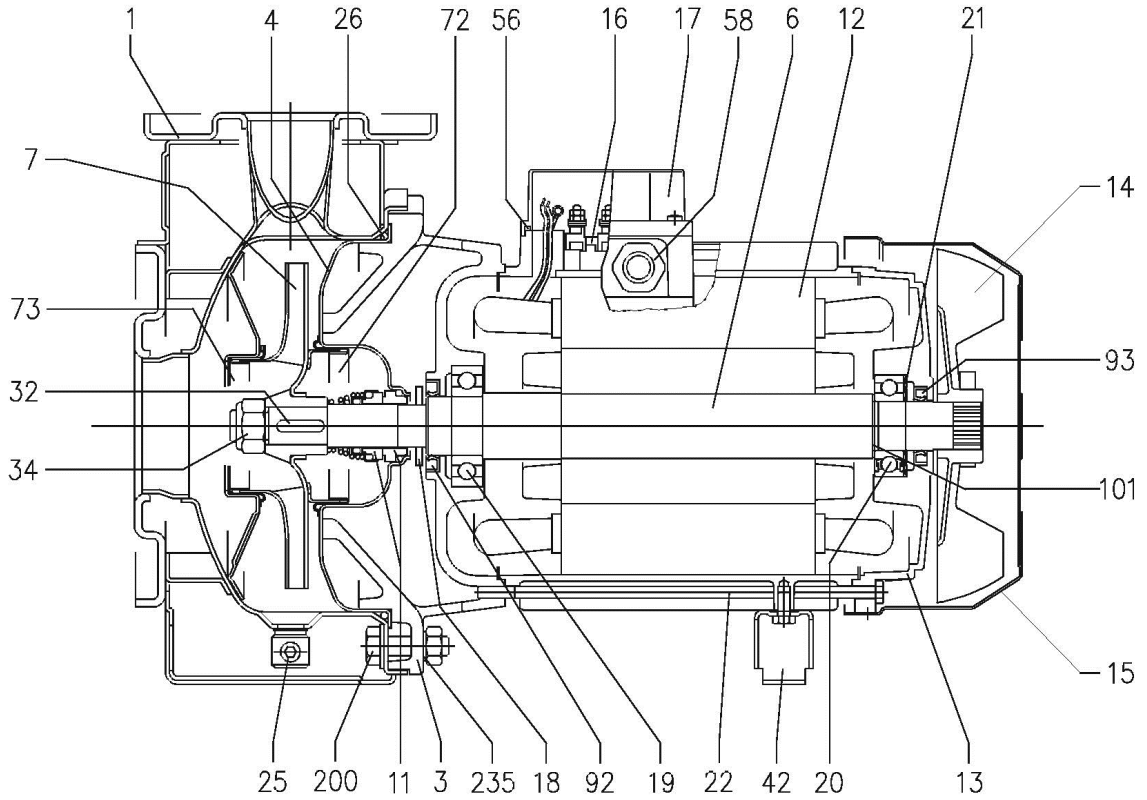

15 kW AND ABOVE

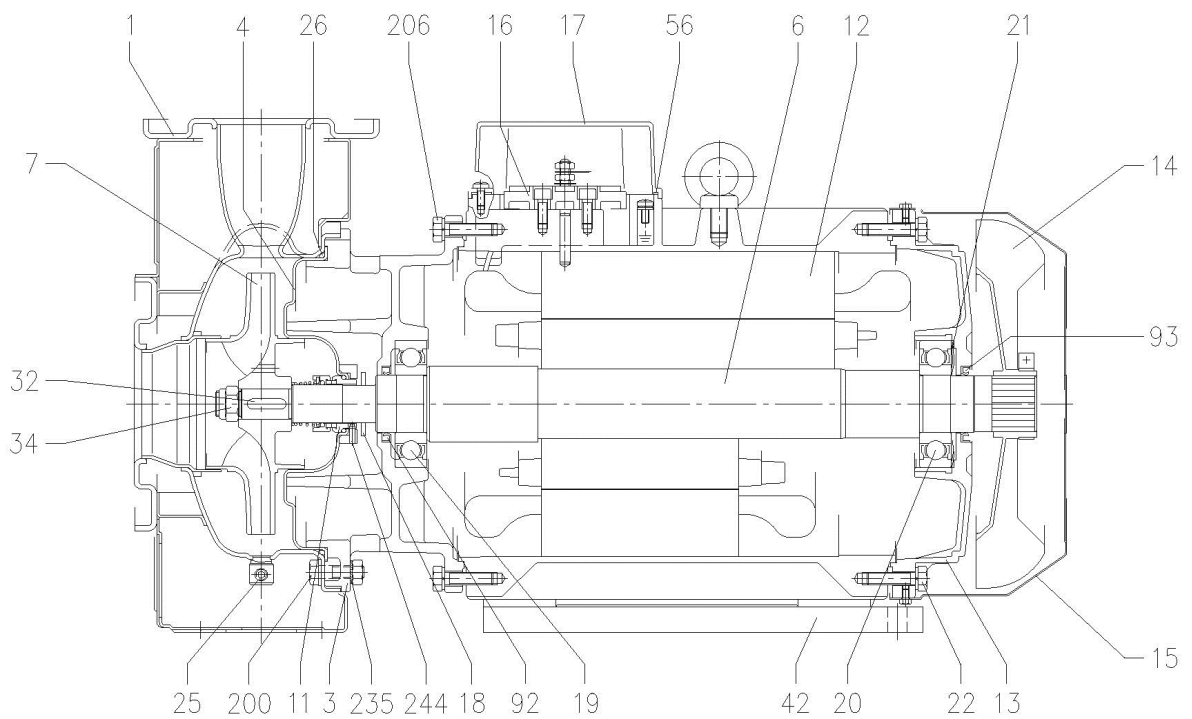

(2/3)

Construction

Pump Name 3LM 40-200/9.26 IE3

Customer	Date	2024-06-20	Company
Contact	Item no.		Issued by
Phone	Project		Phone
E-mail	Project ID	Proiect redenumit 2024-06-20 10:03:09	E-mail

N°	PART NAME	MATERIAL		DIMENSIONS	STANDARD	Q.TY
		3M	3LM			
1	Casing	EN 1.4301 (AISI 304)	EN 1.4404 (AISI 316L)			1
3	Motor bracket	[3]	-			1
4	Casing cover	EN 1.4301 (AISI 304)	EN 1.4404 (AISI 316L)			1
6	Shaft with rotor-Part in contact with liquid	EN 1.4301 (AISI 304)	EN 1.4404 (AISI 316L)			1
7	Impeller	EN 1.4301 (AISI 304)	EN 1.4404 (AISI 316L)			1
11	Mechanical seal	[5]	-			1
12	Motor frame with stator		-			1
13	Motor cover		Aluminium			1
14	Fan		PA			1
15	Fan cover		Fe P04 Zincate			1
16	Terminal		-			1
17	Terminal box cover		Aluminium (three phase version)			1
18	Splash ring	NBR	-	40x21.5x3	EBARA DRAWING	[6]
19	Bearing	[7]	-			1
20	Bearing		-			1
21	Adjusting ring		Steel C70			1
22	Tie rod	For 2.2 - 3 kW For 4 - 5.5 - 7.5 kW For 9.2 - 11 - 15 kW	Fe 42 Zincate	M5 M6 M8	EBARA DRAWING	4
25	Draing plug		EN 1.4401 (AISI 316) / PTFE	R 1/8" L=8	DIN 906	1
26	O-ring	32-125, 40-125 40-160, 50-125 32-160, 32-200, 40-200, 50-160	NBR/FPM/EPDM FPM/EPDM	158.11x5.34 183.52x5.34 227.96x5.34	OR 6625 OR 6720 OR 6895	1
32	Key		EN 1.4401 (AISI 316)	6x6x25	UNI 6604	1
34	Impeller nut		A.270 EN ISO 35062	M16x1.5	UNI 7474	1
42	Foot		Aluminium / Zincate steel		EBARA DRAWING	1
56	Box gasket		NBR			1
58	Fasting nut		-			1
72	Casing ring	[1]	EN 1.4301 (AISI 304) EN 1.4301 (AISI 304)	EN 1.4404 (AISI 316L) EN 1.4404 (AISI 316L)		1
73	Casing ring					1
92	Lip seal	For 2.2 - 3 kW For 4 - 5.5 - 7.5 kW For 9.2 - 11 - 15 kW	-	-	DIN 3760 without spring	1
93	Lip seal	For 2.2 - 3 kW For 4 - 5.5 - 7.5 kW For 9.2 - 11 - 15 kW	-	-	DIN 3760 without spring	1
101	Snap ring (only for 9.2 - 11 - 15 kW)		Carbon tool steels TC 80	Ø 40	UNI 7435	1
200	Screw	32-125, 40-125 32-160, 32-200, 40-160, 40-200, 50-125, 50-160	Stainless steel A2 70 class ISO 3506/1	M 8x30 M 10x35	UNI 5739 UNI 5739	8 [2]
235	Washer	32-125, 40-125 32-160, 32-200, 40-160, 40-200, 50-125, 50-160	EN 1.4301 (AISI 304)	M8.4x17 M10.5x21	UNI 6592	8 [2]

[1] For versions 32-200/5.56, 32-200/7.56, 40-200/5.5, 40-200/9.26, 40-200/156, 50-160/9.26, 50-160/156

[2] Quantity =10 for 32-160, 40-160, 50-125

Quantity =12 for 32-200, 40-200, 50-160

[3] Aluminium EN 1706 AC 46000 D for version, 40-200/9.26, 40-200/156, 50-160/9.26, 50-160/156

Cast iron EN-GJL-200-EN 1561 for other versions.

[4] See **MECHANICAL SEAL**, "O-ring" column, see CONSTRUCTION 3

[5] See **MECHANICAL SEAL**, see CONSTRUCTION 3

[6] Quantity =1, not for L version

[7] See **BEARINGS**, CONSTRUCTION 3

[8] CF8M – EN 1.4408 (AISI316) material for 65-125 up to 65-200

(3/3)

Construction

Pump Name 3LM 40-200/9.26 IE3

Customer	Date 2024-06-20	Company
Contact	Item no.	Issued by
Phone	Project	Phone
E-mail	Project ID Proiect redenumit 2024-06-20 10:03:09	E-mail

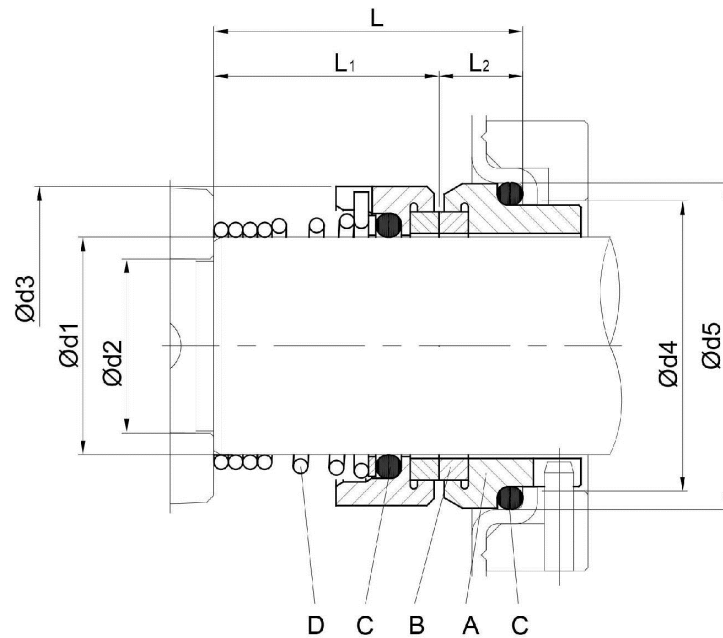

Version	Pump type	Dimensions [mm]									Material Standard			
		d1	d2	d3	d4	d5	L	L1	L2	A Stationary seal ring	B Rotary seal ring	C O-ring	D Frame + spring	
L	32-125/160/200 40-125/160/200 50-125/160 65-125 65-160/7,56-9,26-116	22	19	36	31	37	37.5	27.5	9.5	SiC	SiC	FPM	EN 1.4401 (AISI 316)	