

# Technical Data

Pump Name

3LP4 80-160/2.2R

Customer	Date	10.06.2024	Company
Contact	Item no.		Issued by
Phone	Project		Phone
E-mail	Project ID		E-mail

## Requested data

1	Pump type	CENTRIFUGAL PUMPS	Fluid	Water	
2	Number of pumps / Reserve	1 / 0	Liquid temperature	°C	20
3	Flow	m³/h	Kin. viscosity	cSt	1.005
4	Head	m	Vapour pressure	kPa	2.34
5	Geodetic head	m	PH value		
6	Inlet pressure (pin)	kPa	Density	kg/m³	998.3
7	Available system NPSH		Solids	Weight %	0
8	Ambient temperature	°C	20		

## Pump

9	Pump Name	3LP4 80-160/2.2R	Frequency	Hz	50		
10	Design	CENTRIFUGAL PUMPS	Installation type		STANDARD		
11	Manufacturer	EBARA	Impeller Diameter	Max.	mm	165	
12	Speed	rpm		1400	Designed	mm	165
13	No. of Stage	1		Min.	mm	165	
14	Connection	Suction side	DIN 2532	Flow	Operating	m³/h	
15	Connection	Discharge side	DIN 2532		Max-	m³/h	120
16	Max Working Pressure	kPa	1000		Min-	m³/h	36
17	Shut-off head	kPa	84.21	Head	Operating	m	
18	Total weight	kg	See the table of "Dimensions".		- (Qmax.)	m	3.0
19	Shaft power	kW			- (Qmin.)	m	8.1
20				Max. Shaft Power at max. impeller	kW	1.80	
21	Required pump NPSH	m		Efficiency	%		

## Materials

22	Impeller	AISI 316		
23	Casing	AISI 316		
24	Shaft	AISI 316L		
25				
26				
27				

## Motor

28	Manufacturer	LAFERT	Insulation class	F		
29	Type	TEFC_3LP480-160/2.2R_230_Three Phase	Phases	3~		
30	Specific design	IE3 / 50 Hz / Pole pairs 2	Frame size	100 L		
31	Rated power	kW	2.2	Weight	kg	
32	Number of poles	4	Electric voltage	V	230	
33	Speed	rpm	1400	Electric current	A	10.2
34	Degree of protection	IP 55				
35						

## Remarks

--

# Performance Curve

Pump Name

3LP4 80-160/2.2R

Customer	Date	10.06.2024	Company
Contact	Item no.		Issued by
Phone	Project		Phone
E-mail	Project ID		E-mail

## Requested data

1	Flow	m³/h	
2	Head	m	
3	Geodetic head	m	

## Pump

Operating flow	m³/h		Frequency	Hz	50
Operating head	m		Number of poles		4
Impeller diameter designed	mm	165	Speed	rpm	1400

Test standard: ISO 9906:2012 - Grade3B

Water; 20°C; 998.3kg/m³; 1cSt

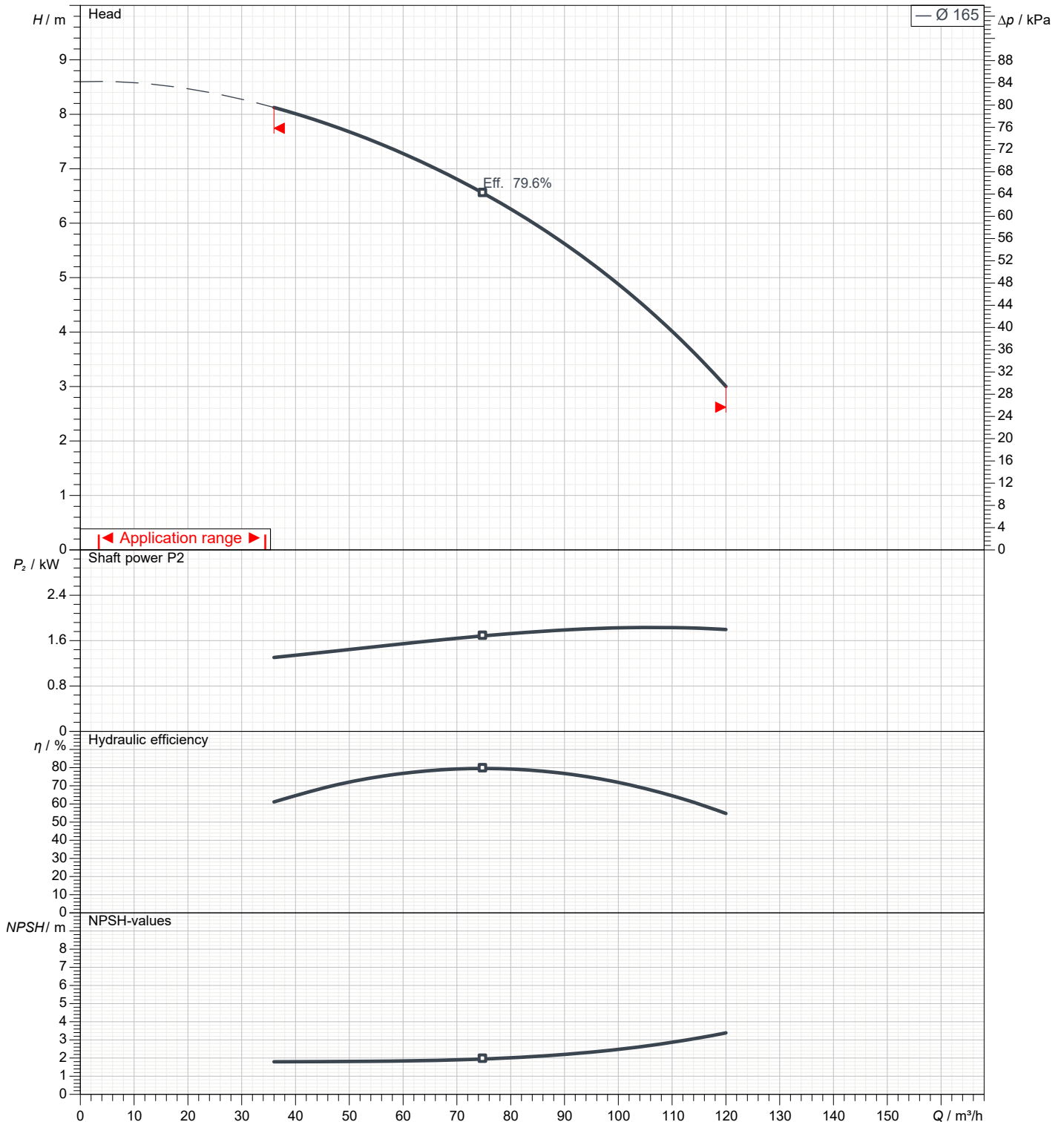

# Dimensions

Pump Name 3LP4 80-160/2.2R

Customer	Date 10.06.2024	Company
Contact	Item no.	Issued by
Phone	Project	Phone
E-mail	Project ID	E-mail

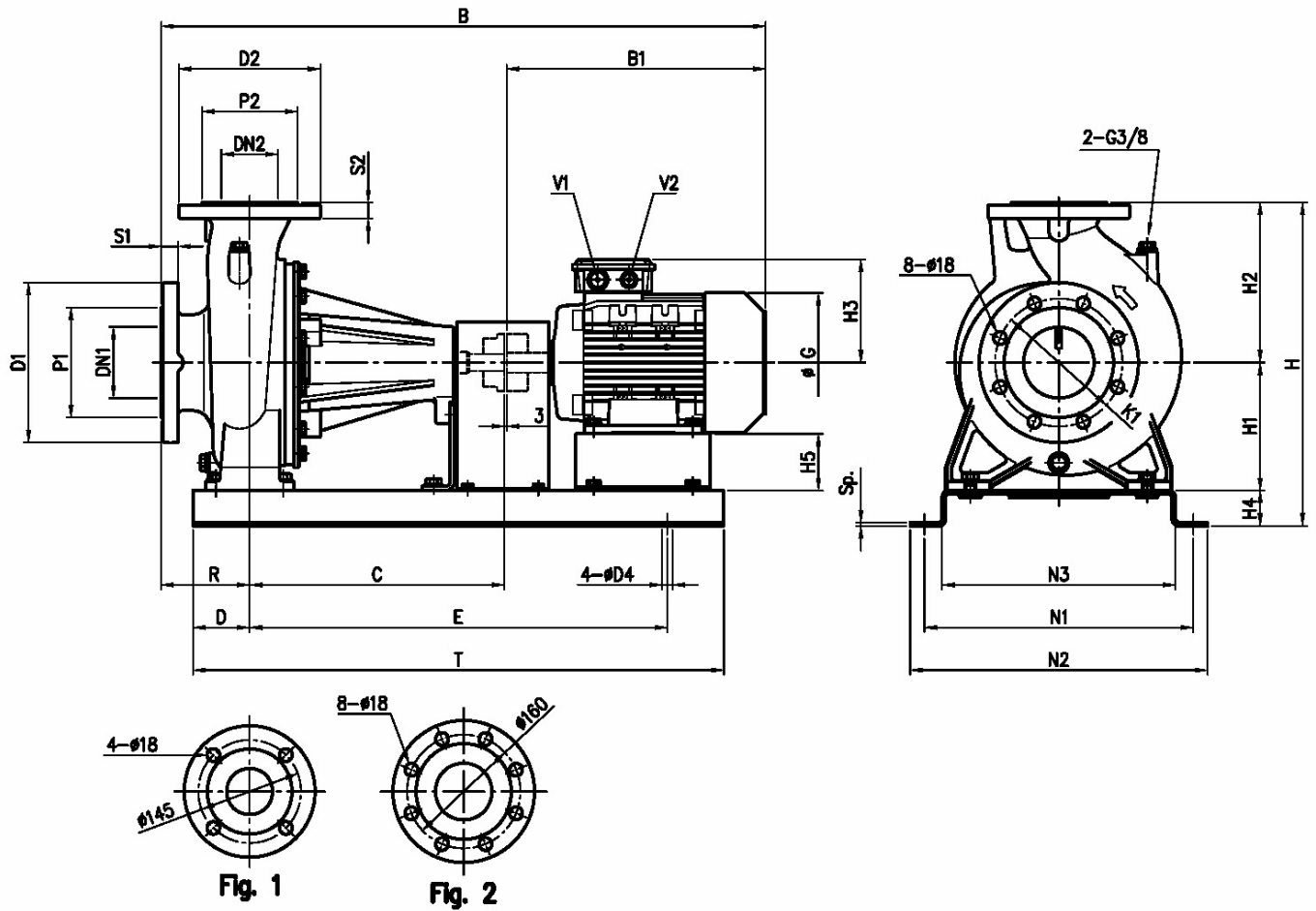

Dimensions in		mm		
1	B	854	H2	225
2	B1	366	H3	155
3	C	360	H4	50
4	D	80	H5	80
5	D4	15	N1	380
6	Dia D1	225	N2	420
7	Dia D2	200	N3	330
8	Dia DN1	100	R	125
9	Dia DN2	80 Fig. 2	S1	24
10	Dia P1	155	S2	22
11	Dia P2	135	SP	5
12	E	590	T	750
13	G	196	V1	M25X1,5
14	H	455	V2	M20X1,5
15	H1	180	Weight P&M	86,4 kg

(1/3)

# Construction

Pump Name 3LP4 80-160/2.2R

Customer	Date 10.06.2024	Company
Contact	Item no.	Issued by
Phone	Project	Phone
E-mail	Project ID	E-mail

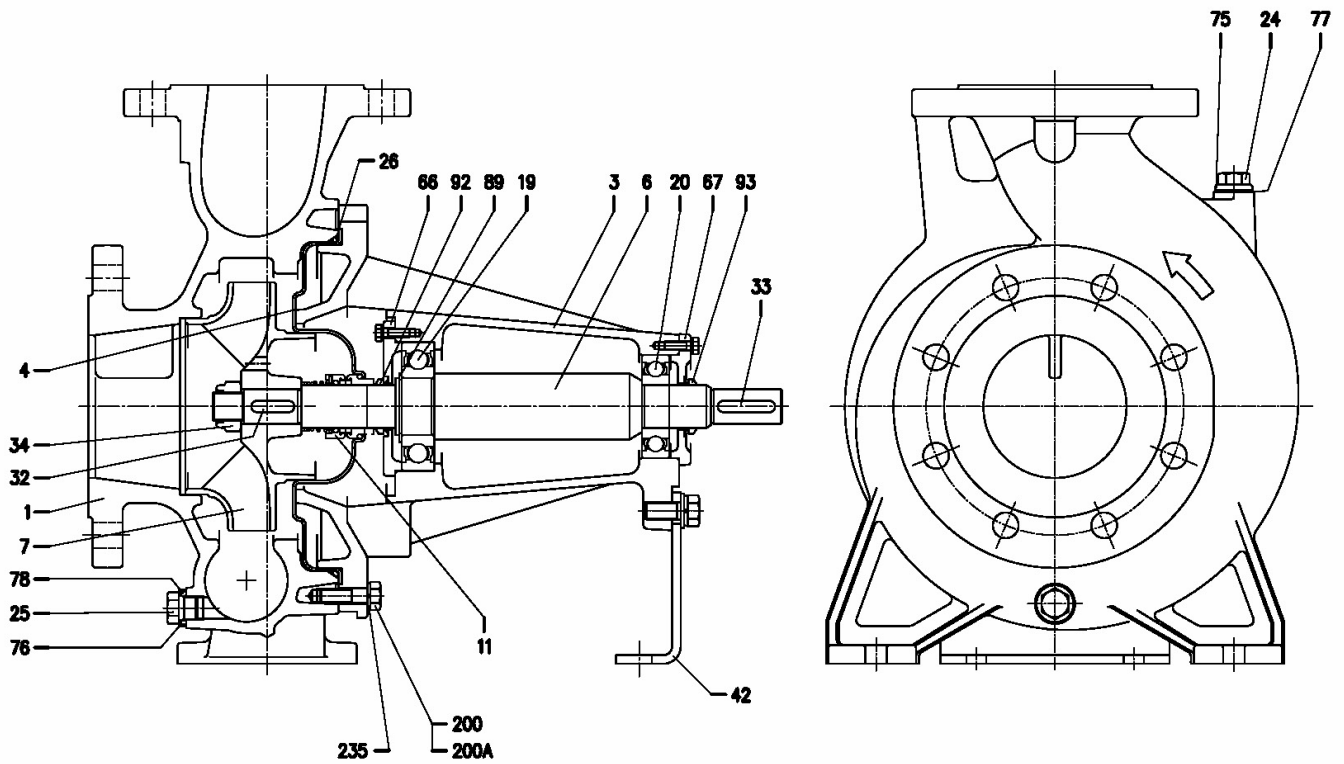

(2/3)

# Construction

Pump Name 3LP4 80-160/2.2R

Customer	Date 10.06.2024	Company
Contact	Item no.	Issued by
Phone	Project	Phone
E-mail	Project ID	E-mail

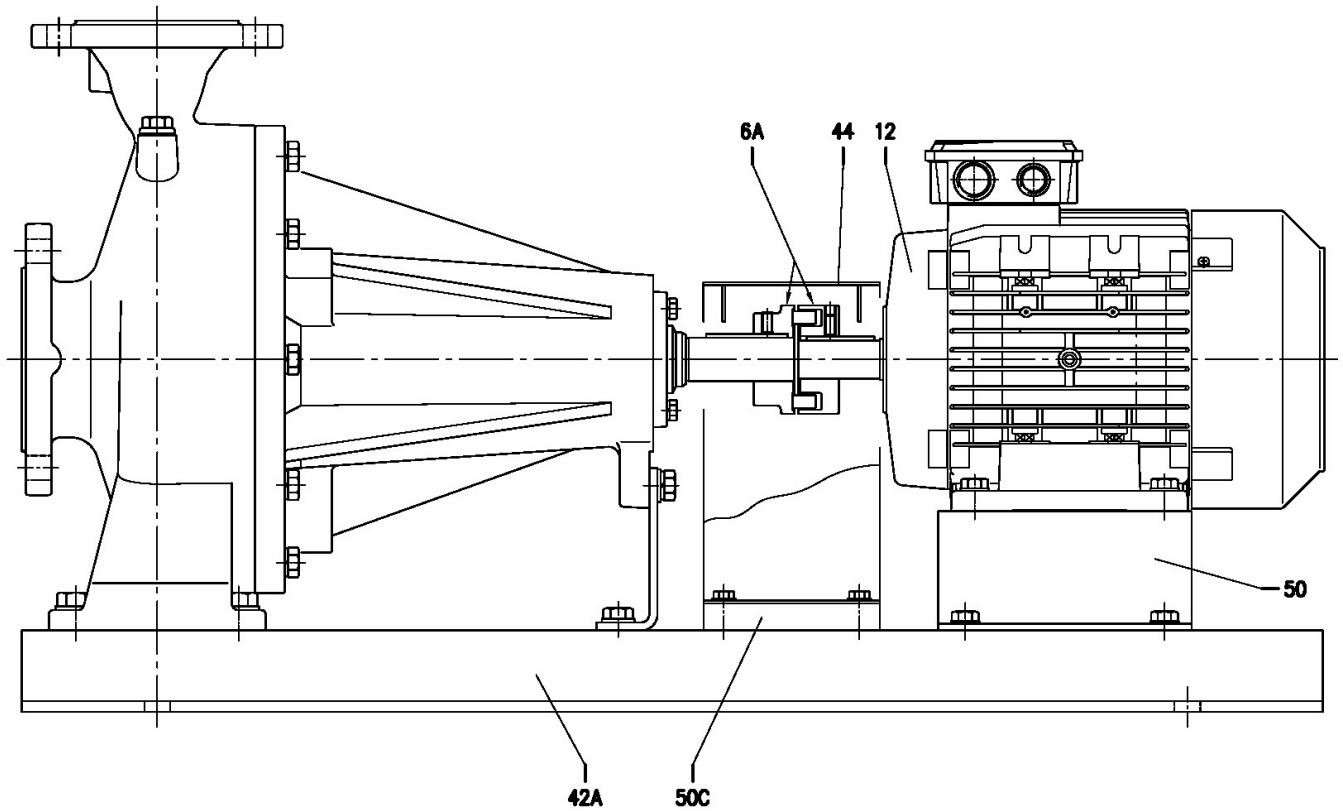

(3/3)

# Construction

Pump Name 3LP4 80-160/2.2R

Customer	Date 10.06.2024	Company
Contact	Item no.	Issued by
Phone	Project	Phone
E-mail	Project ID	E-mail

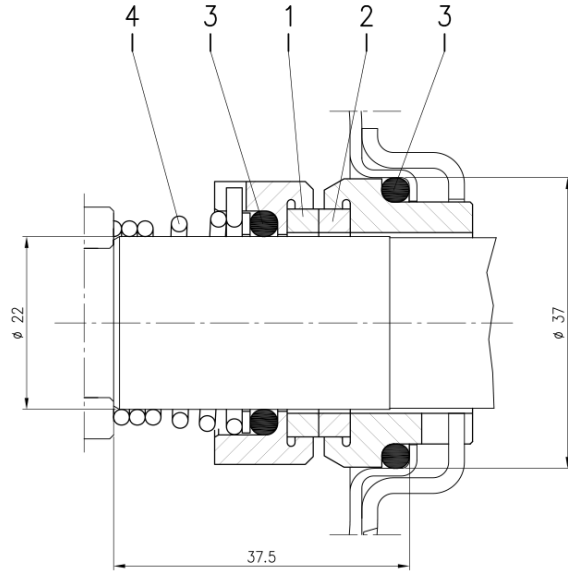

Version	Pump type	Material			
		1 Stationary seal ring	2 Rotary seal ring	3 Rubber	4 Frame + spring
L ø22	32-125/160/200 40-125/160/200 50-125/160/200 65-125/160/200 80-160	SiC	SiC	FPM	EN 1.4571 (AISI 316Ti)