

Technical Data

Pump Name

3LPF4 40-125

Customer	Date	10.06.2024	Company
Contact	Item no.		Issued by
Phone	Project		Phone
E-mail	Project ID		E-mail

Requested data

1	Pump type	CENTRIFUGAL PUMPS	Fluid	Water
2	Number of pumps / Reserve	1 / 0	Liquid temperature	°C
3	Flow	m³/h	Kin. viscosity	cSt
4	Head	m	Vapour pressure	kPa
5	Geodetic head	m	PH value	
6	Inlet pressure (pin)	kPa	Density	kg/m³
7	Available system NPSH		Solids	Weight %
8	Ambient temperature	°C		

Pump

9	Pump Name	3LPF4 40-125	Frequency	Hz	50	
10	Design	CENTRIFUGAL PUMPS	Installation type		STANDARD	
11	Manufacturer	EBARA	Impeller Diameter	Max.	mm	
12	Speed	rpm		1400	Designed	mm
13	No. of Stage	1		Min.	mm	140
14	Connection	Suction side	DIN 2532	Flow	Operating	m³/h
15	Connection	Discharge side	DIN 2532		Max-	m³/h
16	Max Working Pressure	kPa	1000		Min-	m³/h
17	Shut-off head	kPa	63.59	Head	Operating	m
18	Total weight	kg	See the table of "Dimensions".		- (Qmax.)	m
19	Shaft power	kW			- (Qmin.)	m
20				Max. Shaft Power at max. impeller	kW	0.30
21	Required pump NPSH	m		Efficiency	%	

Materials

22	Impeller	AISI 316L		
23	Casing	AISI 316L		
24	Shaft	AISI 316L		
25				
26				
27				

Motor

28	Manufacturer	without motor	Insulation class	
29	Type	without motor 3	Phases	
30	Specific design	without motor / 50 Hz / Pole pairs 2	Frame size	
31	Rated power	kW	Weight	kg
32	Number of poles	4	Electric voltage	V
33	Speed	rpm	Electric current	A
34	Degree of protection			
35				

Remarks

Performance Curve

Pump Name

3LPF4 40-125

Customer	Date	10.06.2024	Company
Contact	Item no.		Issued by
Phone	Project		Phone
E-mail	Project ID		E-mail

Requested data

1	Flow	m³/h	
2	Head	m	
3	Geodetic head	m	

Pump

Operating flow	m³/h		Frequency	Hz	50
Operating head	m		Number of poles		4
Impeller diameter designed	mm	140	Speed	rpm	1400

Test standard: ISO 9906:2012 - Grade3B

Water; 20°C; 998.3kg/m³; 1cSt

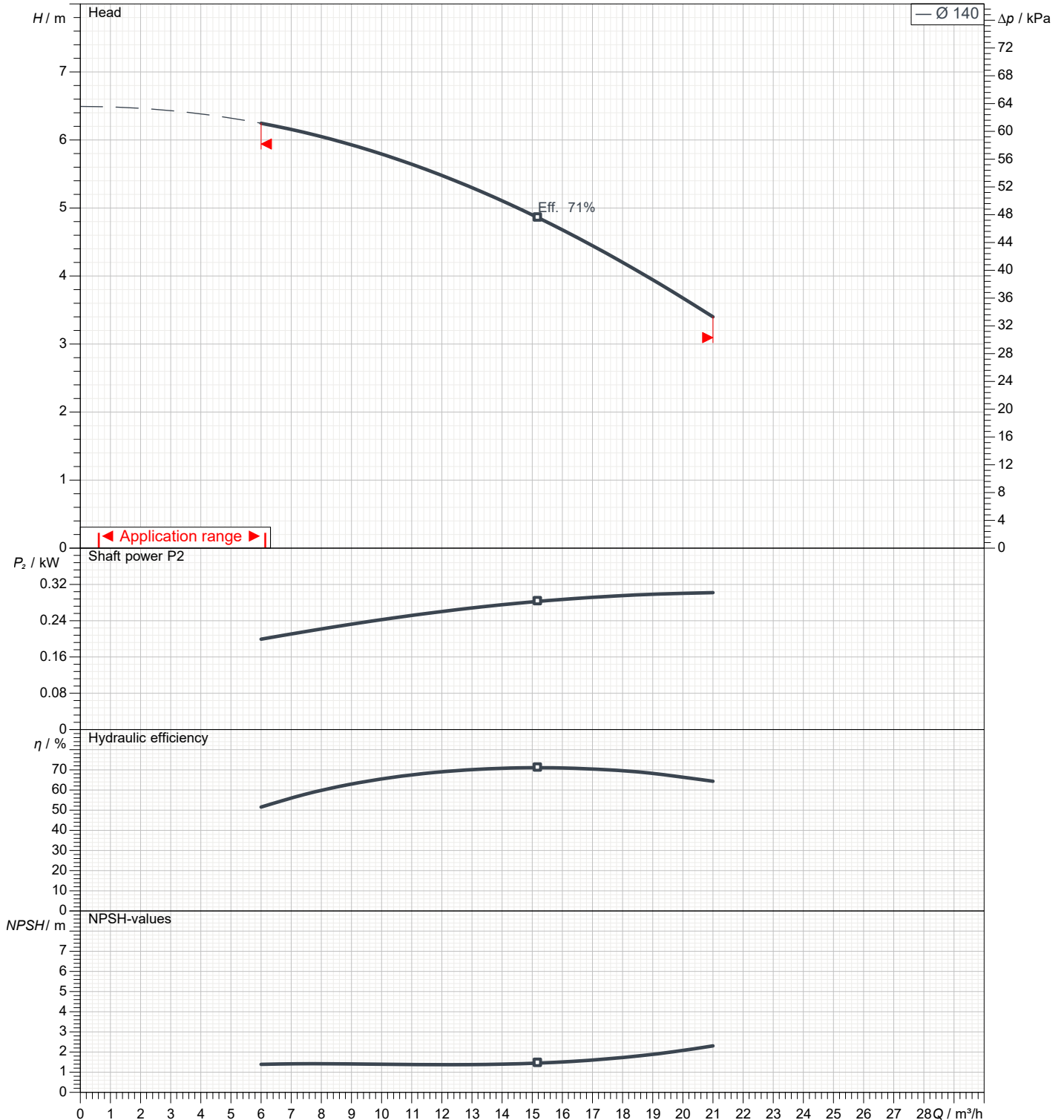

Dimensions

Pump Name 3LPF4 40-125

Customer	Date 10.06.2024	Company
Contact	Item no.	Issued by
Phone	Project	Phone
E-mail	Project ID	E-mail

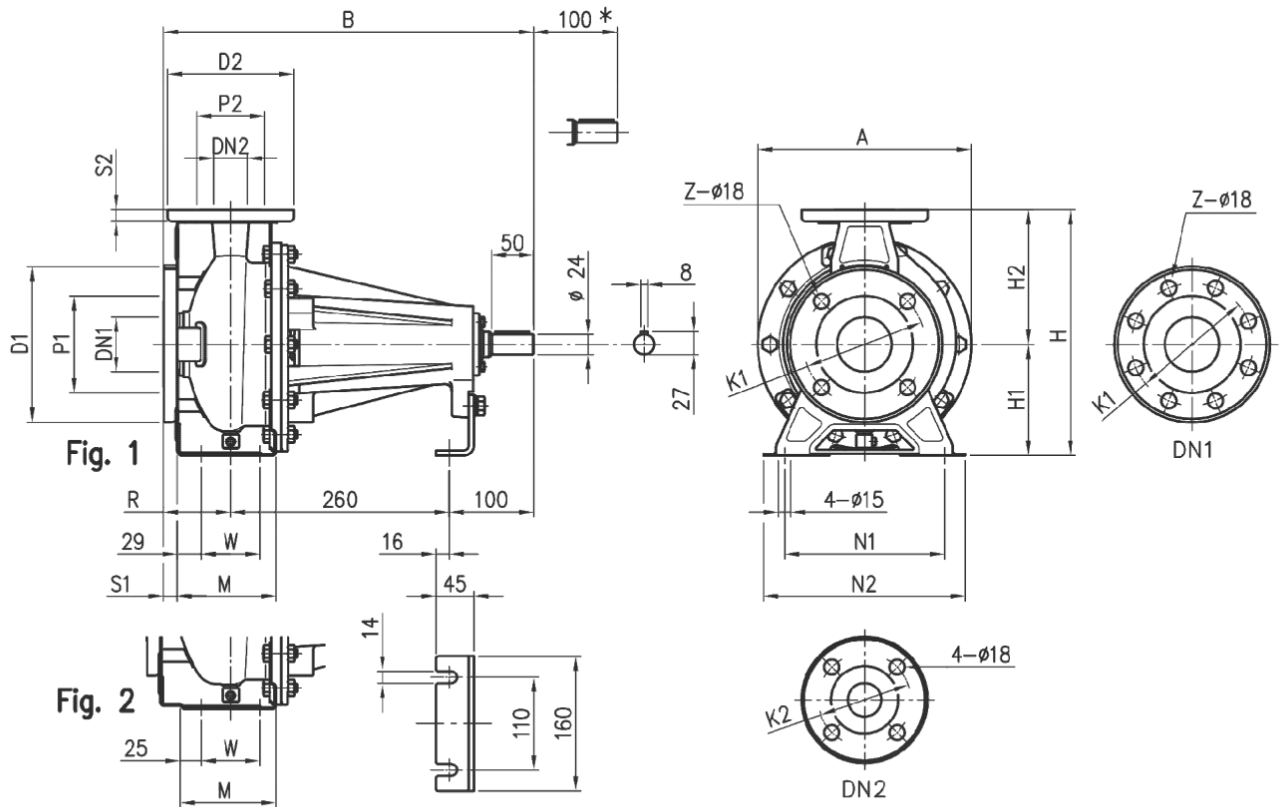

* Space for disassembly

Dimensions in		mm						
1	A	213	N1	160				
2	B	440	N2	210				
3	Dia D1	185	R	80				
4	Dia D2	150	S1	16				
5	Dia DN1	65	S2	14				
6	Dia DN2	40	W	70				
7	Dia K1	145	Weight PUMP	17 kg				
8	Dia K2	110	Z	4				
9	Dia P1	115						
10	Dia P2	80						
11	Fig	1						
12	H	252						
13	H1	112						
14	H2	140						
15	M	114						

(1/3)

Construction

Pump Name 3LPF4 40-125

Customer	Date 10.06.2024	Company
Contact	Item no.	Issued by
Phone	Project	Phone
E-mail	Project ID	E-mail

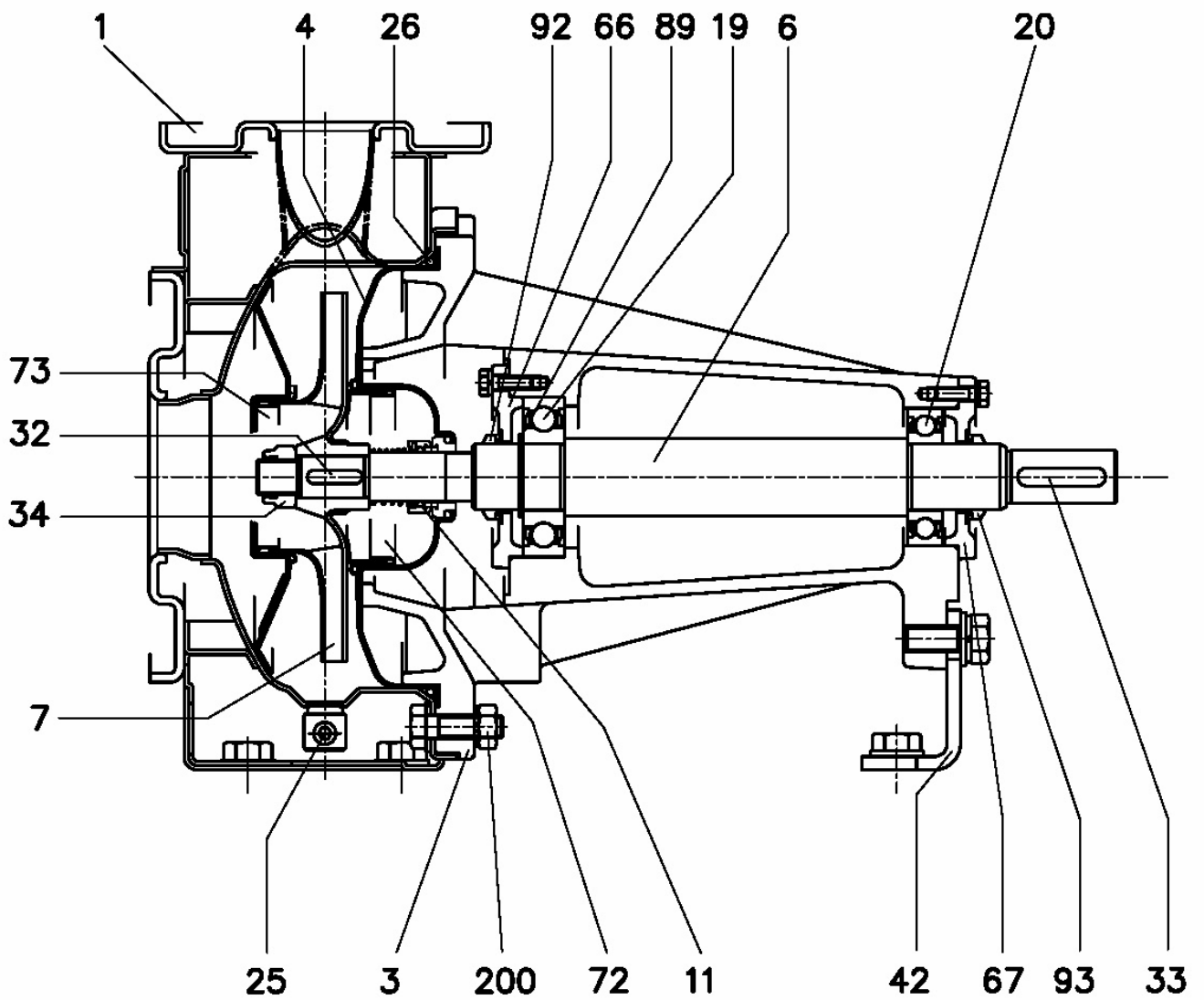

(2/3)**Construction****Pump Name 3LPF4 40-125**

Customer	Date 10.06.2024	Company
Contact	Item no.	Issued by
Phone	Project	Phone
E-mail	Project ID	E-mail

N°	PART NAME	MATERIAL		DIMENSIONS	STANDARD	Q.TY	
		3PF(4)	3LPF(4)				
1	Casing	EN 1.4301 (AISI 304)	EN 1.4404 (AISI 316L)			1	
3	Support	Cast iron EN-GJL-200-EN 1561				1	
4	Casing cover	EN 1.4301 (AISI 304)	EN 1.4404 (AISI 316L)			1	
6	Shaft - Part in contact with liquid	EN 1.4301 (AISI 304)	EN 1.4404 (AISI 316L)			1	
7	Impeller 32-40-50	EN 1.4301 (AISI 304)	EN 1.4404 (AISI 316L)			1	
	65-125/160/200	EN 1.4401 (AISI 316)					
11	Mechanical seal [3]	Carbon/Ceramic/NBR	SiC/SiC/FPM			1	
19	Bearing	-				1	
20	Bearing	-				1	
25	Draining plug	EN 1.4401 (AISI 316) / PTFE		R 1/8" L=8	DIN 906	1	
26	O ring	NBR [4]	FPM	32-125, 40-125	158.11x5.34	OR 6625	1
				32-160, 40-160, 50-125, 65-125	183.52x5.34	OR 6720	
				32-200, 40-200, 50-160, 50-200, 65-160, 65-200	227.96x5.34	OR 6895	
32	Key	EN 1.4401 (AISI 316)		6x6x25	UNI 6604	1	
33	Key	C 40		8x7x40	UNI 6604	1	
34	Impeller nut	EN 1.4301 (AISI 304)	EN 1.4404 (AISI 316L)	Other model	M16x1.5	UNI 7474	1
	50-200/2.2			M18x1.5			
42	Pump support	Zinc-coated steel			EBARA DRAWING	1	
66	Impeller side bearing cover	Cast iron EN-GJL-200-EN 1561				1	
67	Motor side bearing cover	Cast iron EN-GJL-200-EN 1561				1	
72	Casing ring (not for 65 version) [1]	EN 1.4301 (AISI 304)	EN 1.4404 (AISI 316L)			1	
73	Casing ring (not for 65 version)	EN 1.4301 (AISI 304)	EN 1.4404 (AISI 316L)			1	
89	Snap ring 32-125, 32-160, 40-125, 50-125	Carbon tool steel TC 80		Ø30	UNI 7435	1	
	Other model			Ø40			
92	O ring	-		VS - 0030		1	
93	O ring	-		VS - 0030		1	
200	Screw	Stainless steel A2 70 class ISO 3506/1		32-125, 40-125	M 8x30	UNI 5739	8
				40-160, 40-200, 50-125, 50-160, 50-200, 65-125, 65-160, 65-200	M 10x35	UNI 5739	

[1] For version: 32-200, 40-200, 50-160, 50-200

[2] N° for 1 unit=10 for 32-160, 40-160, 50-125, 65-125

N° for 1 unit=12 for 32-200, 40-200, 50-160, 50-200, 65-160, 65-200

[3] Special version: see CONSTRUCTION 3

[4] FPM for H-HS-HW-HSW option

EPDM for E version, Q1AEGG, U3U3EGG, Q1Q1EGG, Q1U3EGG, U3CEGG

(3/3) Construction

Pump Name 3LPF4 40-125

Customer	Date 10.06.2024	Company
Contact	Item no.	Issued by
Phone	Project	Phone
E-mail	Project ID	E-mail

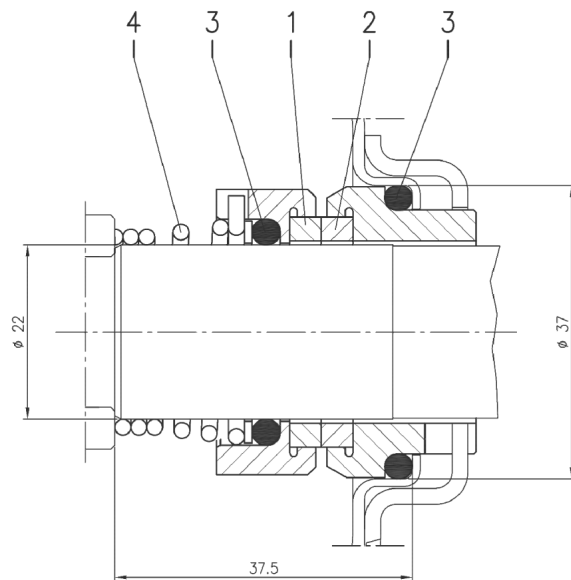

Version	Pump type	Material			
		1 Stationary seal ring	2 Rotary seal ring	3 Rubber	4 Frame + spring
L ø22	32-125/160/200 40-125/160/200 50-125/160/200 65-125/160/200 80-160	SiC	SiC	FPM	EN 1.4571 (AISI 316Ti)