

Technical Data

Pump Name

3LPF 40-200/L

Customer	Date	10.06.2024	Company
Contact	Item no.		Issued by
Phone	Project		Phone
E-mail	Project ID		E-mail

Requested data

1	Pump type	CENTRIFUGAL PUMPS	Fluid	Water
2	Number of pumps / Reserve	1 / 0	Liquid temperature	°C
3	Flow	m³/h	Kin. viscosity	cSt
4	Head	m	Vapour pressure	kPa
5	Geodetic head	m	PH value	
6	Inlet pressure (pin)	kPa	Density	kg/m³
7	Available system NPSH		Solids	Weight %
8	Ambient temperature	°C		

Pump

9	Pump Name	3LPF 40-200/L	Frequency	Hz	50	
10	Design	CENTRIFUGAL PUMPS	Installation type		STANDARD	
11	Manufacturer	EBARA	Impeller Diameter	Max.	mm	
12	Speed	rpm		2900	Designed	mm
13	No. of Stage	1		Min.	mm	224
14	Connection	Suction side	DIN 2532	Flow	Operating	m³/h
15	Connection	Discharge side	DIN 2532		Max-	m³/h
16	Max Working Pressure	kPa	1000		Min-	m³/h
17	Shut-off head	kPa	705.43	Head	Operating	m
18	Total weight	kg	See the table of "Dimensions".		- (Qmax.)	m
19	Shaft power	kW			- (Qmin.)	m
20				Max. Shaft Power at max. impeller	kW	9.90
21	Required pump NPSH	m		Efficiency	%	

Materials

22	Impeller	AISI 316L		
23	Casing	AISI 316L		
24	Shaft	AISI 316L		
25				
26				
27				

Motor

28	Manufacturer	without motor	Insulation class	
29	Type	without motor 3	Phases	
30	Specific design	without motor / 50 Hz / Pole pairs 1	Frame size	
31	Rated power	kW	Weight	kg
32	Number of poles	2	Electric voltage	V
33	Speed	rpm	Electric current	A
34	Degree of protection			
35				

Remarks

Performance Curve

Pump Name

3LPF 40-200/L

Customer	Date	10.06.2024	Company
Contact	Item no.		Issued by
Phone	Project		Phone
E-mail	Project ID		E-mail

Requested data

1	Flow	m³/h	
2	Head	m	
3	Geodetic head	m	

Pump

Operating flow	m³/h		Frequency	Hz	50
Operating head	m		Number of poles		2
Impeller diameter designed	mm	224	Speed	rpm	2900

Test standard: ISO 9906:2012 - Grade3B

Water; 20°C; 998.3kg/m³; 1cSt

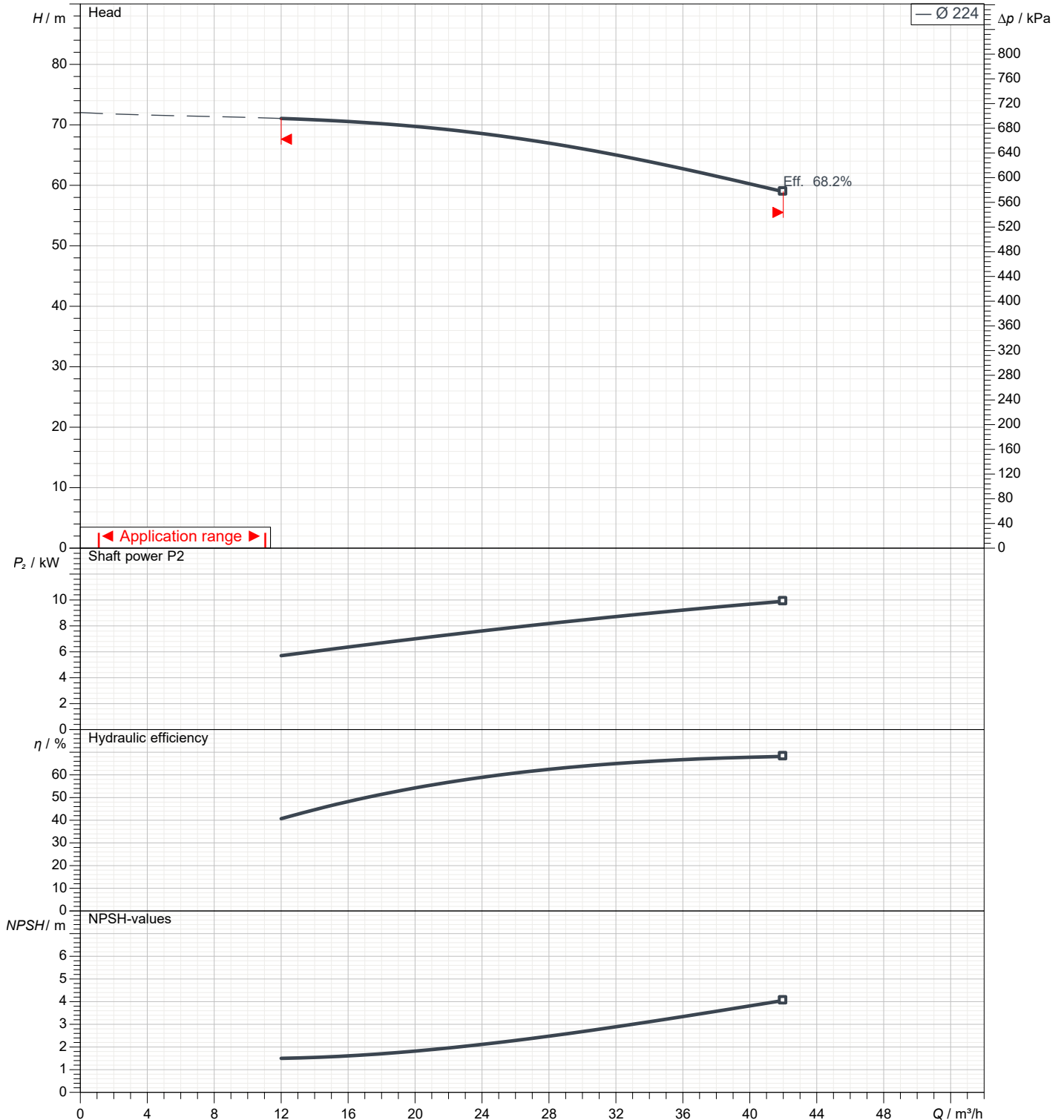

Dimensions

Pump Name 3LPF 40-200/L

Customer	Date 10.06.2024	Company
Contact	Item no.	Issued by
Phone	Project	Phone
E-mail	Project ID	E-mail

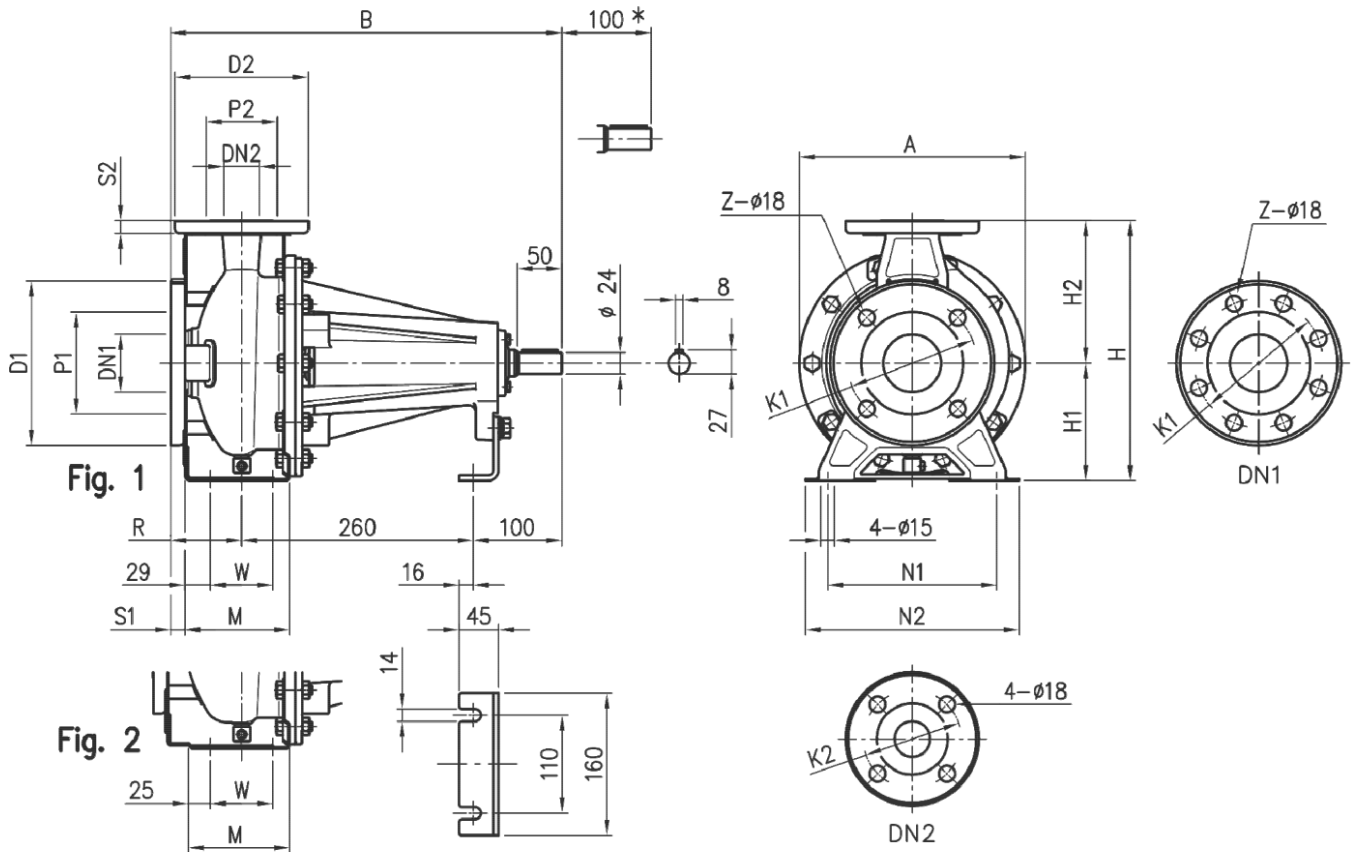

* Space for disassembly

Dimensions in		mm						
1	A	296	N1	212				
2	B	460	N2	265				
3	Dia D1	185	R	100				
4	Dia D2	150	S1	16				
5	Dia DN1	65	S2	14				
6	Dia DN2	40	W	70				
7	Dia K1	145	Weight PUMP	27 kg				
8	Dia K2	110	Z	4				
9	Dia P1	115						
10	Dia P2	80						
11	Fig	2						
12	H	340						
13	H1	160						
14	H2	180						
15	M	115						

(1/3)

Construction

Pump Name 3LPF 40-200/L

Customer	Date 10.06.2024	Company
Contact	Item no.	Issued by
Phone	Project	Phone
E-mail	Project ID	E-mail

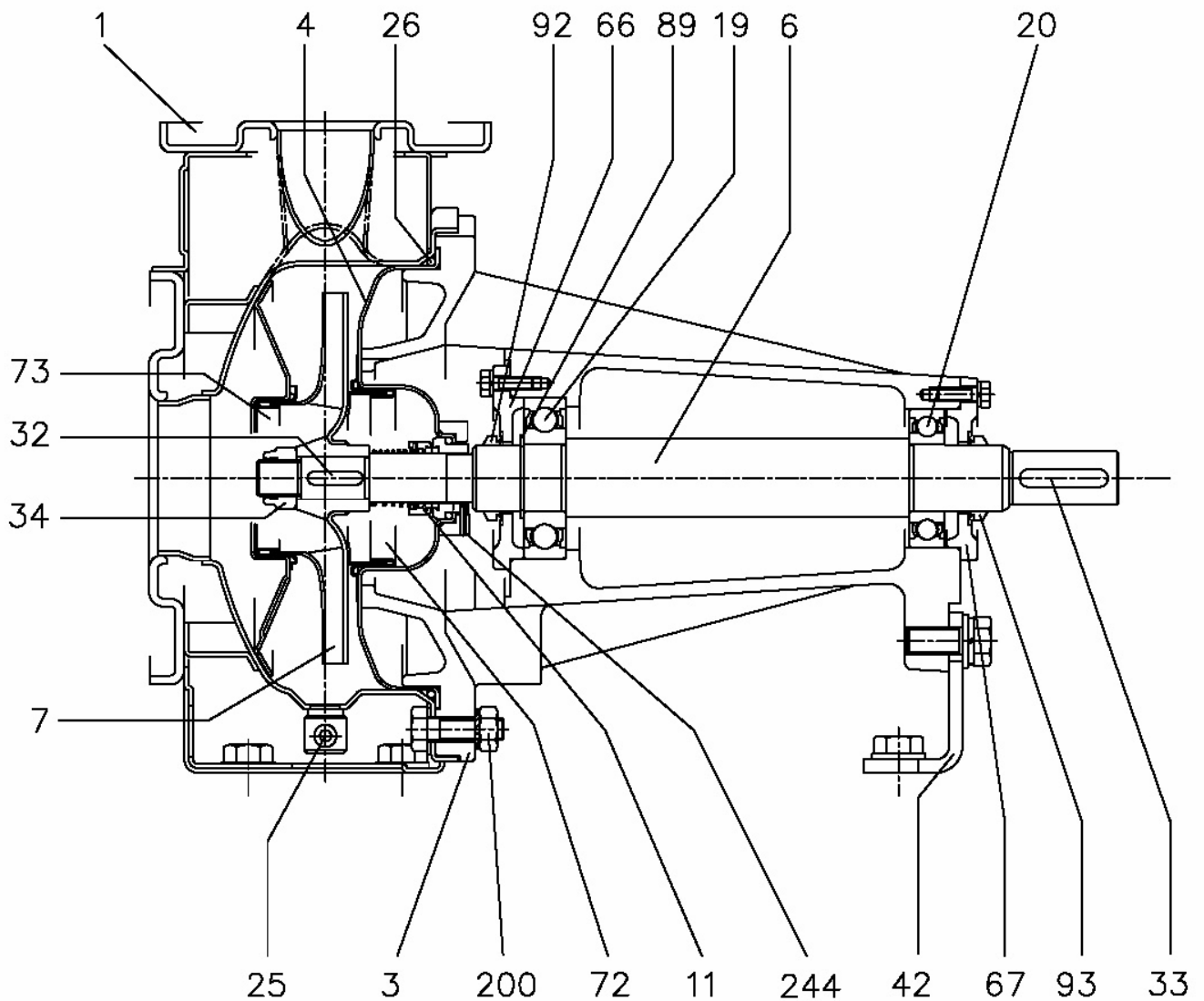

(2/3)**Construction****Pump Name 3LPF 40-200/L**

Customer	Date 10.06.2024	Company
Contact	Item no.	Issued by
Phone	Project	Phone
E-mail	Project ID	E-mail

N°	PART NAME	MATERIAL		DIMENSIONS	STANDARD	Q.TY
		3P	3LP			
1	Casing	EN 1.4301 (AISI 304)	EN 1.4404 (AISI 316L)			1
3	Support	Cast iron EN-G JL-200-EN 1561				1
4	Casing cover	EN 1.4301 (AISI 304)	EN 1.4404 (AISI 316L)			1
6	Shaft - Part in contact with liquid	EN 1.4301 (AISI 304)	EN 1.4404 (AISI 316L)			1
7	Impeller 32,40,50 65-125/160/200	EN 1.4301 (AISI 304)	EN 1.4404 (AISI 316L)			1
		EN 1.440 1 (AISI 316)				
11	Mechanical seal [4]	Carbon/Ceramic/NBR	SIC/SIC/FPM			1
19	Bearing	-				1
20	Bearing	-				1
25	Draing plug	EN 1.4401 (AISI 316) / PTFE		R 1/8" L=8	DIN 906	1
26	O ring 32-125, 40-125 32-160, 40-160, 50-125, 65-125 32-200, 40-200, 50-160, 50-200, 65-160, 65-200	NBR [5]	FPM	158.11x5.34	OR 6625	1
				183.52x5.34	OR 6720	
				227.96x5.34	OR 6895	
32	Key Up to 11 Kw 15 kW and above	EN 1.4301 (AISI 304)	EN 1.4401 (AISI 316)	6 x6x 25	UNI 6604	1
				8 x7x 30		
33	Key	C 40		8x7x40	UNI 6604	1
34	Impeller nut Up to 11kW 50-200/15 15 kW and above	EN 1.4301 (AISI 304)	EN 1.4404 (AISI 316L)	M16x1.5	UNI 7474	1
				M18x1.5		
				M20x1.5		
42	Pump support	Fe 37 ZI nc-coated			EBARA DRAWING	1
66	Impeller side bearing cover	Cast iron EN-G JL-200-EN 1561				1
67	Motor side bearing cover	Cast iron EN-G JL-200-EN 1561				1
72	Casing ring [1]	EN 1.4301 (AISI 304)	EN 1.4404 (AISI 316L)			1
73	Casing ring (not for 65 version)	EN 1.4301 (AISI 304)	EN 1.4404 (AISI 316L)			1
89	Snap ring	Carbon tool steels TC 80		Ø 40	UNI 7435	1
92	O ring	-		VS - 0030		1
93	O ring	-		VS - 0030		1
200	Screw 32-125, 40-125 40-160, 40-200, 50-125, 50-160, 50-200, 65-125, 65-160, 65-200	Stainless steel A2 70 class ISO 3506/ 1		M 8x30	UNI 5739	8
				M 10x35	UNI 5739	
244	Pin [3]	-	EN 1.4301 (AISI 304)	4x15		1

[1] For version 32-200, 40-200, 50-160, 50-200

[2] Q.TY=10 for 32-160, 40-160, 50-125, 65-125

Q.TY=12 for 32-200, 40-200, 50-160, 50-200, 65-160, 65-200

[3] Only for 65-160/15 and 65-200

[4] Special version: see CONSTRUCTION 3

[5] FPM for H-HS-HW-HSW version

EPDM for E version, Q1AEGG, Q1U3EGG, U3CEGG, Q1Q1EGG, U3U3EGG

U3CU3EGG not available for models 65-160/15 and 65-200

(3/3)

Construction

Pump Name 3LPF 40-200/L

Customer	Date 10.06.2024	Company
Contact	Item no.	Issued by
Phone	Project	Phone
E-mail	Project ID	E-mail

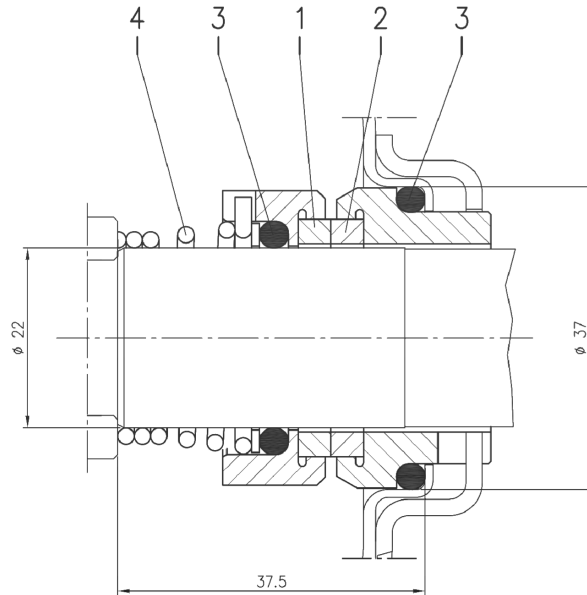

Version	Pump type	Material			
		1 Stationary seal ring	2 Rotary seal ring	3 Rubber	4 Frame + spring
L ø22	32-125/160/200 40-125/160/200 50-125/160/200 65-125 65-160/7.5-9.2-11	SiC	SiC	FPM	EN 1.4571 (AISI 316Ti)