

Technical Data

Pump Name

3LS4 32-160/0.37

Customer	Date	10.06.2024	Company
Contact	Item no.		Issued by
Phone	Project		Phone
E-mail	Project ID		E-mail

Requested data

1	Pump type	CENTRIFUGAL PUMPS	Fluid	Water
2	Number of pumps / Reserve	1 / 0	Liquid temperature	°C
3	Flow	m³/h	Kin. viscosity	cSt
4	Head	m	Vapour pressure	kPa
5	Geodetic head	m	PH value	
6	Inlet pressure (pin)	kPa	Density	kg/m³
7	Available system NPSH		Solids	Weight %
8	Ambient temperature	°C		

Pump

9	Pump Name	3LS4 32-160/0.37	Frequency	Hz	50	
10	Design	CENTRIFUGAL PUMPS	Installation type		STANDARD	
11	Manufacturer	EBARA	Impeller Diameter	Max.	mm	
12	Speed	rpm		1400	Designed	mm
13	No. of Stage	1		Min.	mm	166
14	Connection	Suction side	DIN 2532	Flow	Operating	m³/h
15	Connection	Discharge side	DIN 2532		Max-	m³/h
16	Max Working Pressure	kPa	1000		Min-	m³/h
17	Shut-off head	kPa	88.14	Head	Operating	m
18	Total weight	kg	See the table of "Dimensions".		- (Qmax.)	m
19	Shaft power	kW			- (Qmin.)	m
20			Max. Shaft Power at max. impeller	kW	0.30	
21	Required pump NPSH	m	Efficiency	%		

Materials

22	Impeller	AISI 316L		
23	Casing	AISI 316L		
24	Shaft	AISI 316L		
25				
26				
27				

Motor

28	Manufacturer	LAFERT	Insulation class	F	
29	Type	TEFC_3S432-160/0.37_230_Three Phase	Phases	3~	
30	Specific design	- / 50 Hz / Pole pairs 2	Frame size	71	
31	Rated power	kW	0.37	Weight	kg
32	Number of poles	4	Electric voltage	V	230
33	Speed	rpm	1400	Electric current	A
34	Degree of protection	IP 55			
35					

Remarks

Performance Curve

Pump Name

3LS4 32-160/0.37

Customer	Date	10.06.2024	Company
Contact	Item no.		Issued by
Phone	Project		Phone
E-mail	Project ID		E-mail

Requested data

1	Flow	m³/h	
2	Head	m	
3	Geodetic head	m	

Pump

Operating flow	m³/h		Frequency	Hz	50
Operating head	m		Number of poles		4
Impeller diameter designed	mm	166	Speed	rpm	1400

Test standard: ISO 9906:2012 - Grade3B

Water; 20°C; 998.3kg/m³; 1cSt

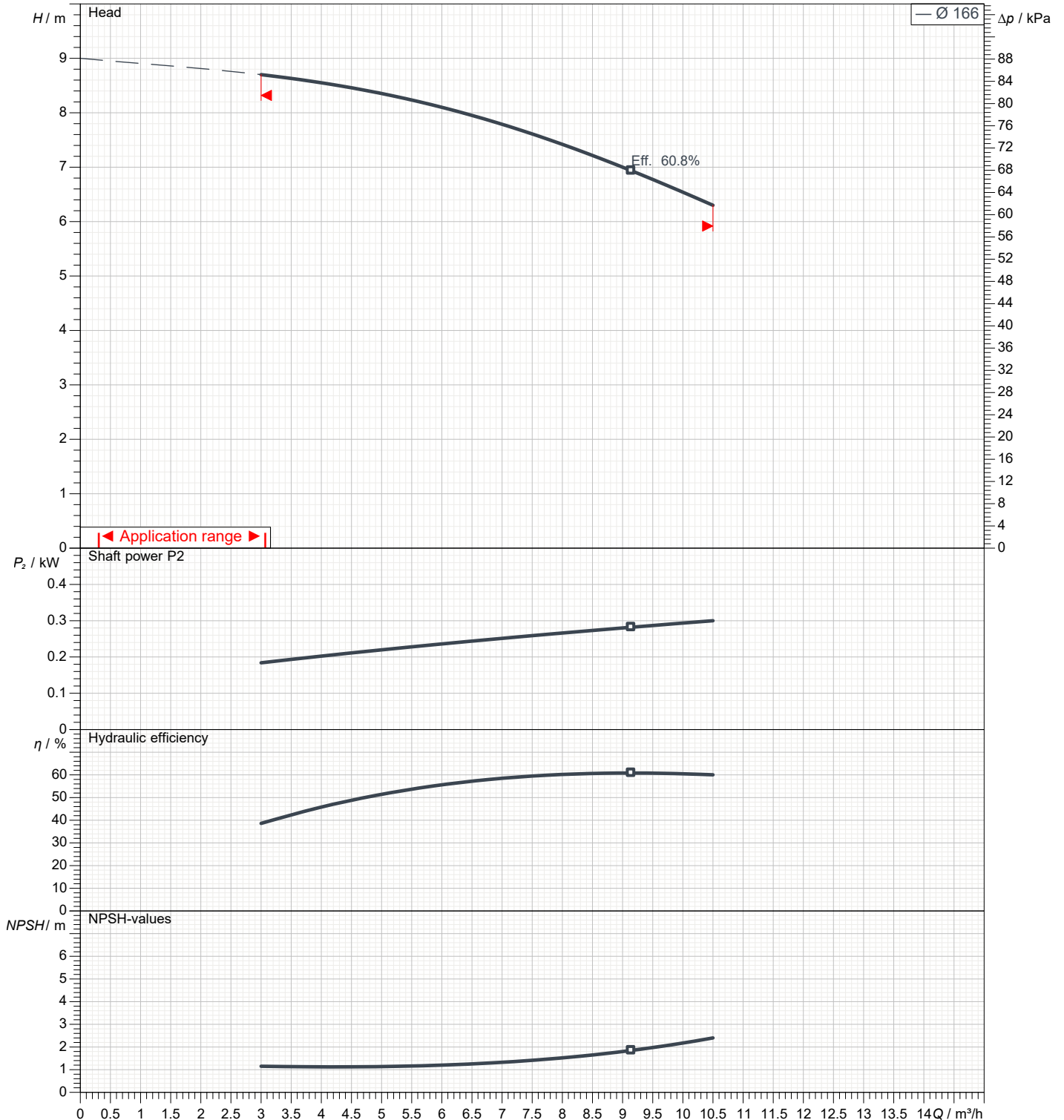

Dimensions

Pump Name 3LS4 32-160/0.37

Customer	Date 10.06.2024	Company
Contact	Item no.	Issued by
Phone	Project	Phone
E-mail	Project ID	E-mail

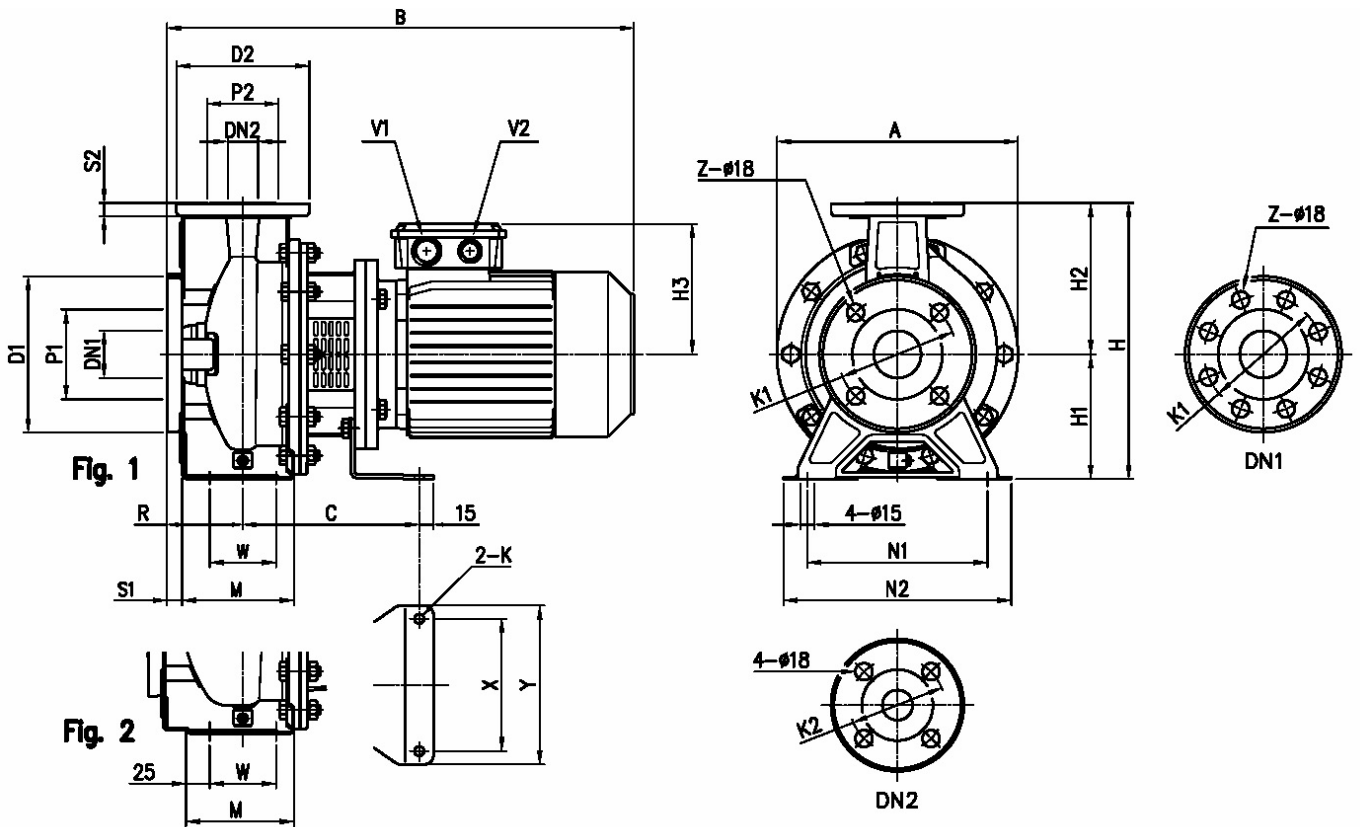

Dimensions in		mm						
1	A	254	H3	114				
2	B	404	K	8				
3	C	153	M	118				
4	Dia D1	165	N1	190				
5	Dia D2	140	N2	240				
6	Dia DN1	50	R	80				
7	Dia DN2	32	S1	16				
8	Dia K1	125	S2	14				
9	Dia K2	100	V1	M20X1,5				
10	Dia P1	95	V2	M16X1,5				
11	Dia P2	75	W	70				
12	Fig	1	Weight P&M	18,7 kg				
13	H	292	X	112				
14	H1	132	Y	140				
15	H2	160	Z	4				

(1/3)

Construction

Pump Name 3LS4 32-160/0.37

Customer	Date 10.06.2024	Company
Contact	Item no.	Issued by
Phone	Project	Phone
E-mail	Project ID	E-mail

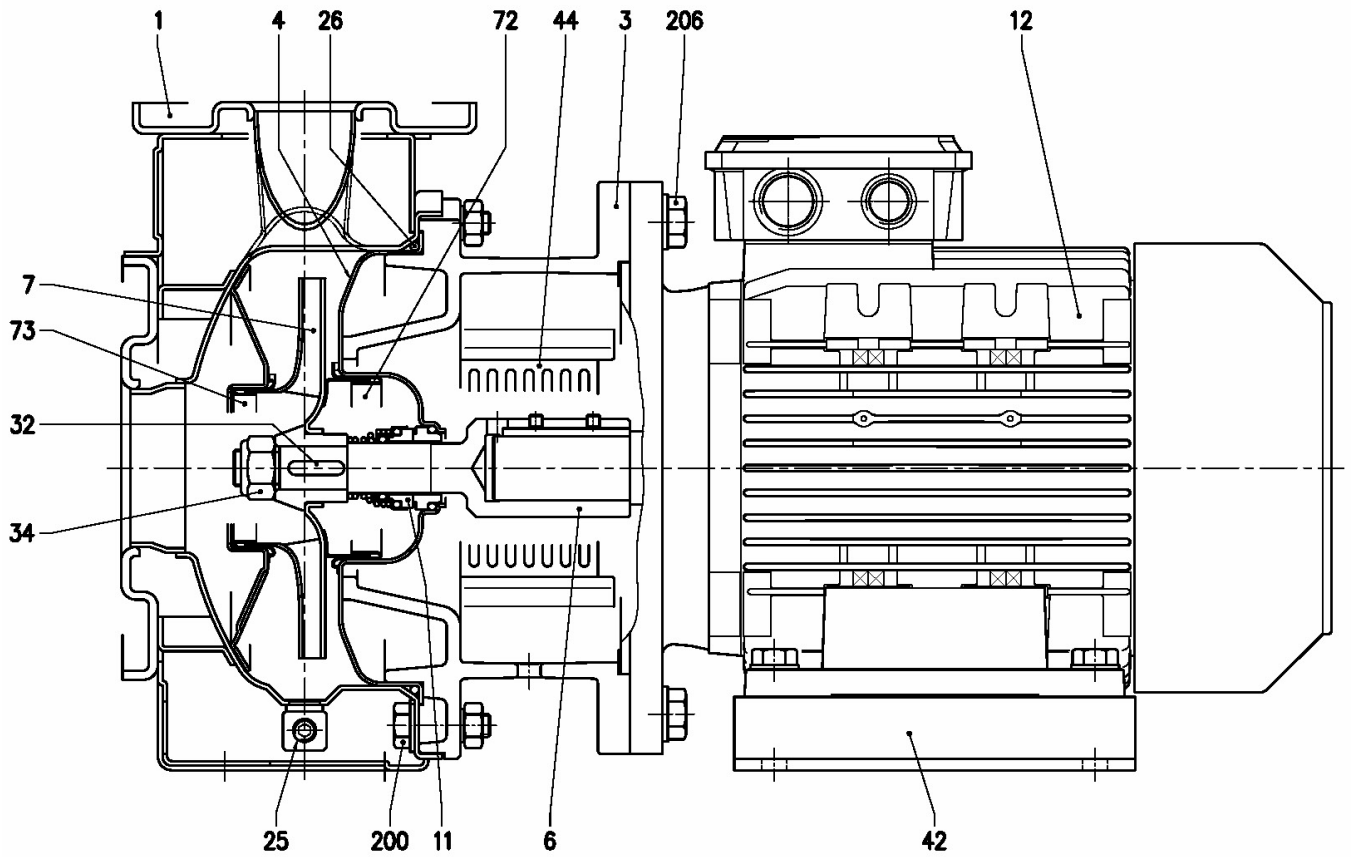

(2/3)

Construction

Pump Name 3LS4 32-160/0.37

Customer	Date 10.06.2024	Company
Contact	Item no.	Issued by
Phone	Project	Phone
E-mail	Project ID	E-mail

N°	PART NAME	MATERIAL		DIMENSIONS	STANDARD	Q.TY	
		3S4	3LS4				
001	Casing	EN 1.4301 (AISI 304)	EN 1.4404 (AISI 316L)			1	
003	Motor bracket	Cast iron EN-GJL-200-EN 1561				1	
004	Casing cover	EN 1.4301 (AISI 304)	EN 1.4404 (AISI 316L)			1	
006	Coupling - Part in contact with liquid	EN 1.4301 (AISI 304)	EN 1.4404 (AISI 316L)			1	
007	Impeller	32, 40, 50 65-125/160/200	EN 1.4301 (AISI 304) CF8M - EN 1.4408 (AISI 316)			1	
011	Mechanical seal [4]	Carbon/Ceramic/NBR	SiC/SiC/FPM			1	
012	Motor	-				1	
025	Draining plug	EN 1.4401 (AISI 316) / PTFE		R 1/8" L=8	DIN 906	1	
026	"O" ring	32-125, 40-125	NBR [5]	FPM	158.11x5.34	OR 6625	1
		32-160, 40-160, 50-125, 65-125			183.52x5.34	OR 6720	
		32-200, 40-200, 50-160, 50-200, 65-160, 65-200			227.96x5.34	OR 6895	
032	Key	EN 1.4401 (AISI 316)		6x6x25	UNI 6604	1	
034	Impeller nut	Other model 50-200/2.2	EN 1.4301 (AISI 304)	EN 1.4404 (AISI 316L)	M16x1.5 M18x1.5	UNI 7474	1
042	Foot	Galvanized steel				[1]	
044	Protection	EN 1.4301 (AISI 304)			EBARA DRAWING	2	
072	Casing ring (not for 65 version) [2]	EN 1.4301 (AISI 304)	EN 1.4404 (AISI 316L)			1	
073	Casing ring (not for 65 version)	EN 1.4301 (AISI 304)	EN 1.4404 (AISI 316L)			1	
200	Screw	32-125, 40-125 40-160, 40-200, 50-125, 50-160, 50-200, 65-125, 65-160, 65-200	Stainless steel A2 70 class ISO 3506/1		M 8x30	UNI 5739	8
		up to 0.37kW from 0.55 to 1.5kW for 2.2 and 3kW			M 10x35	UNI 5739	[3]
206	Screw		Gv. Steel 8.8 strenght class ISO 898/1		M 8x20	UNI 5739	4
					M 10x25		
					M 12x30		

- [1] Quantity = 1 up to 1.5kW
Quantity = 2 for 2.2 and 3kW
- [2] Only for version 32-200, 40-200, 50-160, 50-200
- [3] Quantity = 10 for 32-160, 40-160, 50-125, 65-125
Quantity = 12 for 32-200, 40-200, 50-160, 50-200, 65-160, 65-200
- [4] Special version: see CONSTRUCTION 3
- [5] FPM (H-HS-HW-HSW version)
EPDM (E version)

(3/3)

Construction

Pump Name 3LS4 32-160/0.37

Customer	Date 10.06.2024	Company
Contact	Item no.	Issued by
Phone	Project	Phone
E-mail	Project ID	E-mail

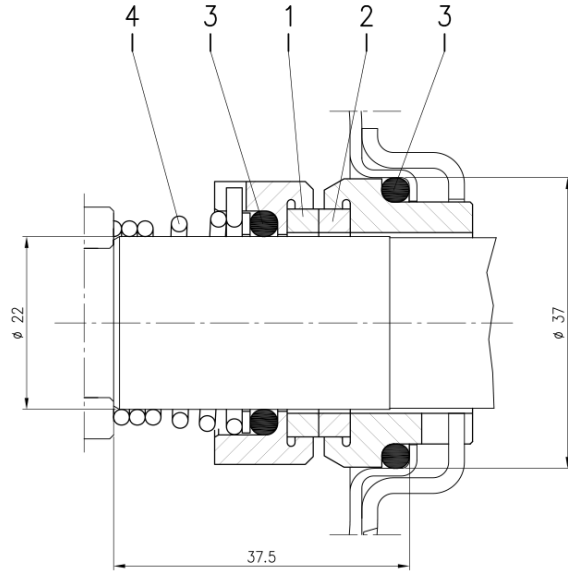

Version	Pump type	Material			
		1 Stationary seal ring	2 Rotary seal ring	3 Rubber	4 Frame + spring
L ø22	32-125/160/200 40-125/160/200 50-125/160/200 65-125/160/200 80-160	SiC	SiC	FPM	EN 1.4571 (AISI 316Ti)