

Technical Data

Pump Name

3LSF 40-200/11

Customer	Date	10.06.2024	Company
Contact	Item no.		Issued by
Phone	Project		Phone
E-mail	Project ID		E-mail

Requested data

1	Pump type	CENTRIFUGAL PUMPS	Fluid	Water
2	Number of pumps / Reserve	1 / 0	Liquid temperature	°C
3	Flow	m³/h	Kin. viscosity	cSt
4	Head	m	Vapour pressure	kPa
5	Geodetic head	m	PH value	
6	Inlet pressure (pin)	kPa	Density	kg/m³
7	Available system NPSH		Solids	Weight %
8	Ambient temperature	°C		

Pump

9	Pump Name	3LSF 40-200/11	Frequency	Hz	50	
10	Design	CENTRIFUGAL PUMPS	Installation type		STANDARD	
11	Manufacturer	EBARA	Impeller Diameter	Max.	mm	
12	Speed	rpm		2900	Designed	mm
13	No. of Stage	1		Min.	mm	224
14	Connection	Suction side	DIN 2532	Flow	Operating	m³/h
15	Connection	Discharge side	DIN 2532		Max-	m³/h
16	Max Working Pressure	kPa	1000		Min-	m³/h
17	Shut-off head	kPa	705.43	Head	Operating	m
18	Total weight	kg	See the table of "Dimensions".		- (Qmax.)	m
19	Shaft power	kW			- (Qmin.)	m
20				Max. Shaft Power at max. impeller	kW	9.90
21	Required pump NPSH	m		Efficiency	%	

Materials

22	Impeller	AISI 316L		
23	Casing	AISI 316L		
24	Shaft	AISI 316L		
25				
26				
27				

Motor

28	Manufacturer	without motor	Insulation class	
29	Type	without motor 3	Phases	
30	Specific design	without motor / 50 Hz / Pole pairs 1	Frame size	
31	Rated power	kW	Weight	kg
32	Number of poles	2	Electric voltage	V
33	Speed	rpm	Electric current	A
34	Degree of protection			
35				

Remarks

Performance Curve

Pump Name

3LSF 40-200/11

Customer	Date	10.06.2024	Company
Contact	Item no.		Issued by
Phone	Project		Phone
E-mail	Project ID		E-mail

Requested data

1	Flow	m³/h	
2	Head	m	
3	Geodetic head	m	

Pump

Operating flow	m³/h		Frequency	Hz	50
Operating head	m		Number of poles		2
Impeller diameter designed	mm	224	Speed	rpm	2900

Test standard: ISO 9906:2012 - Grade3B

Water; 20°C; 998.3kg/m³; 1cSt

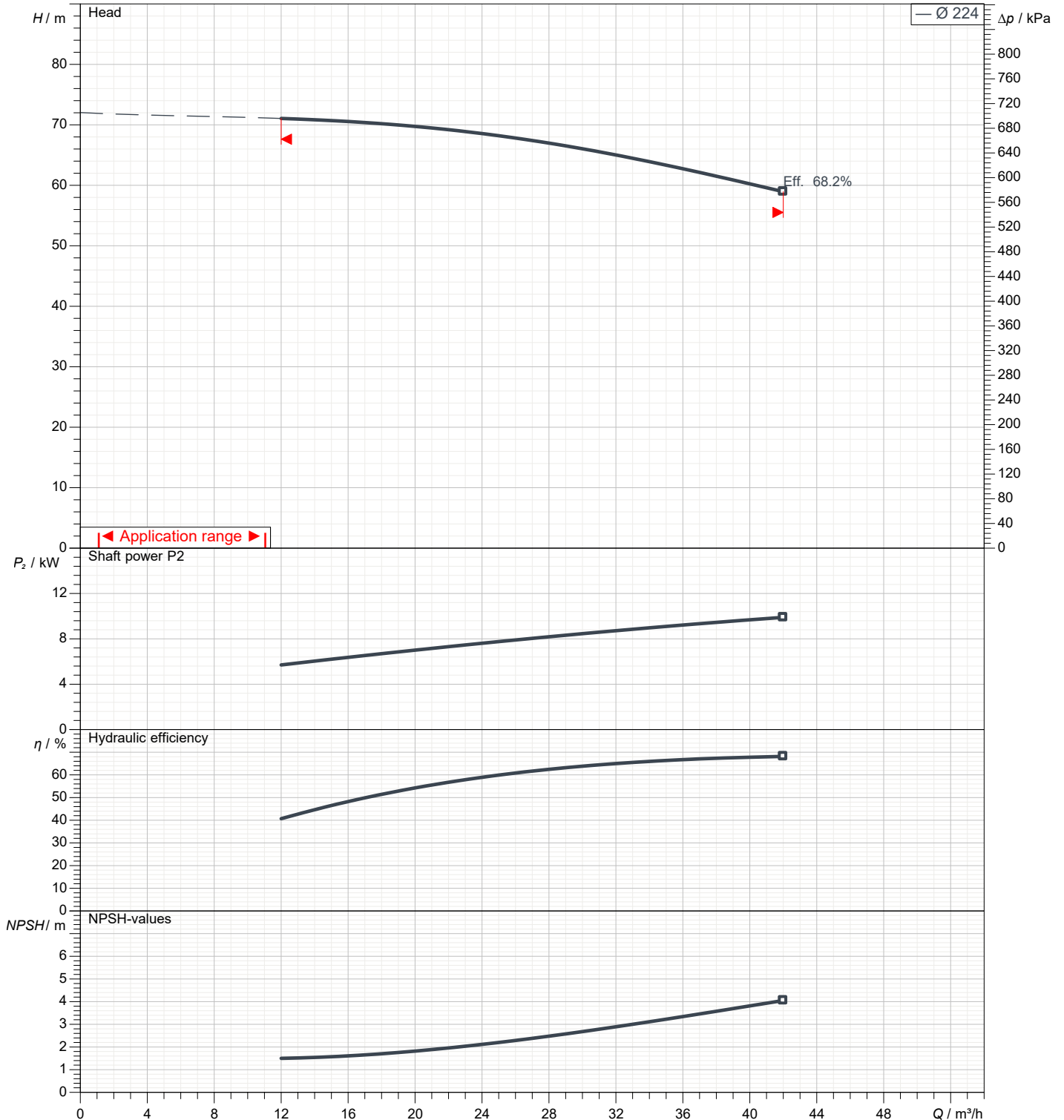

Dimensions

Pump Name 3LSF 40-200/11

Customer	Date 10.06.2024	Company
Contact	Item no.	Issued by
Phone	Project	Phone
E-mail	Project ID	E-mail

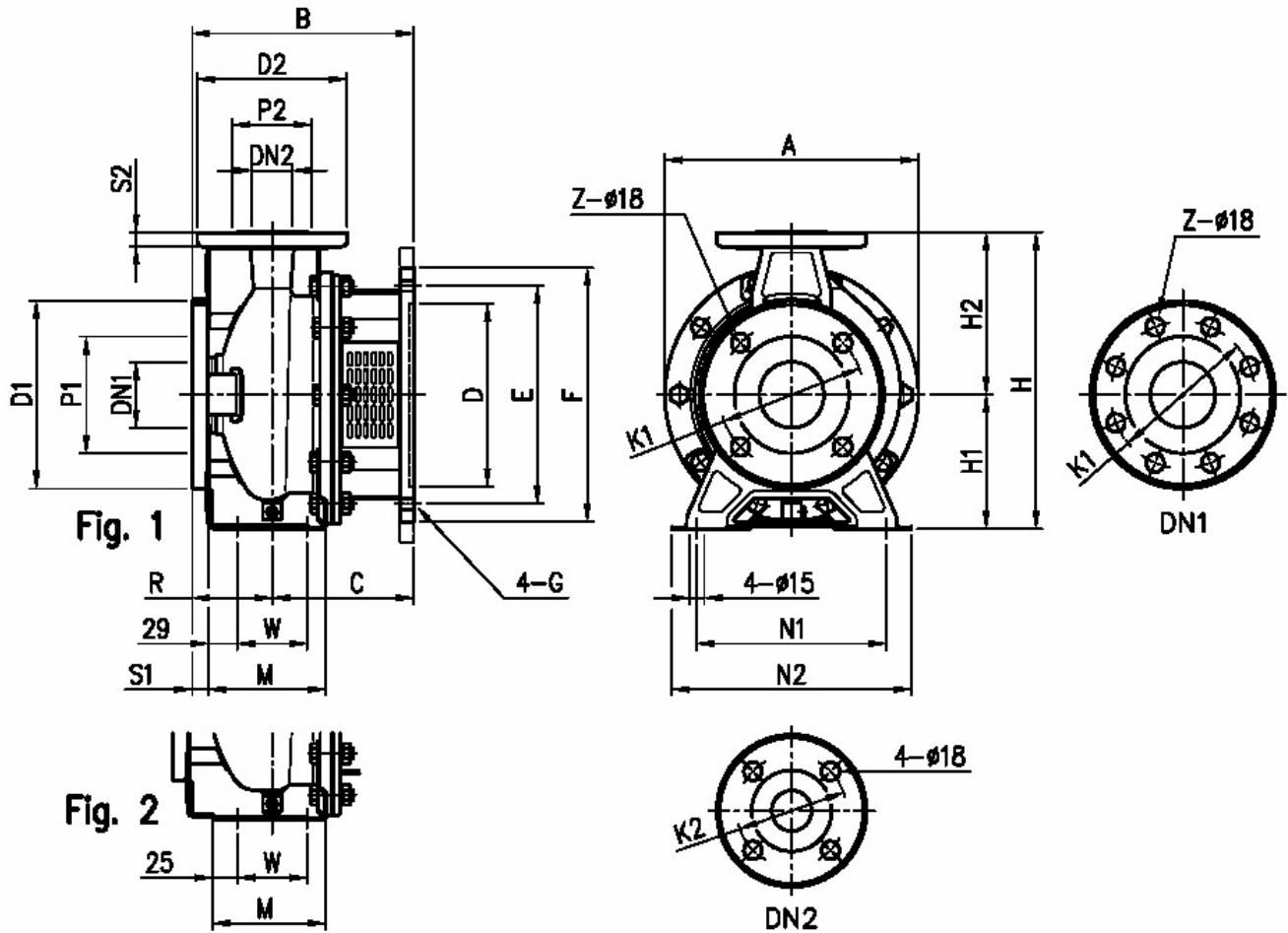

Dimensions in		mm	
1	A	296	G M16
2	B	298	H 340
3	C	198	H1 160
4	D	250	H2 180
5	Dia D1	185	M 115
6	Dia D2	150	N1 212
7	Dia DN1	65	N2 265
8	Dia DN2	40	R 100
9	Dia K1	145	S1 16
10	Dia K2	110	S2 14
11	Dia P1	115	W 70
12	Dia P2	80	Weight PUMP 41,5 kg
13	E	300	Z 4
14	F	350	
15	Fig	2	

(1/3)

Construction

Pump Name 3LSF 40-200/11

Customer	Date 10.06.2024	Company
Contact	Item no.	Issued by
Phone	Project	Phone
E-mail	Project ID	E-mail

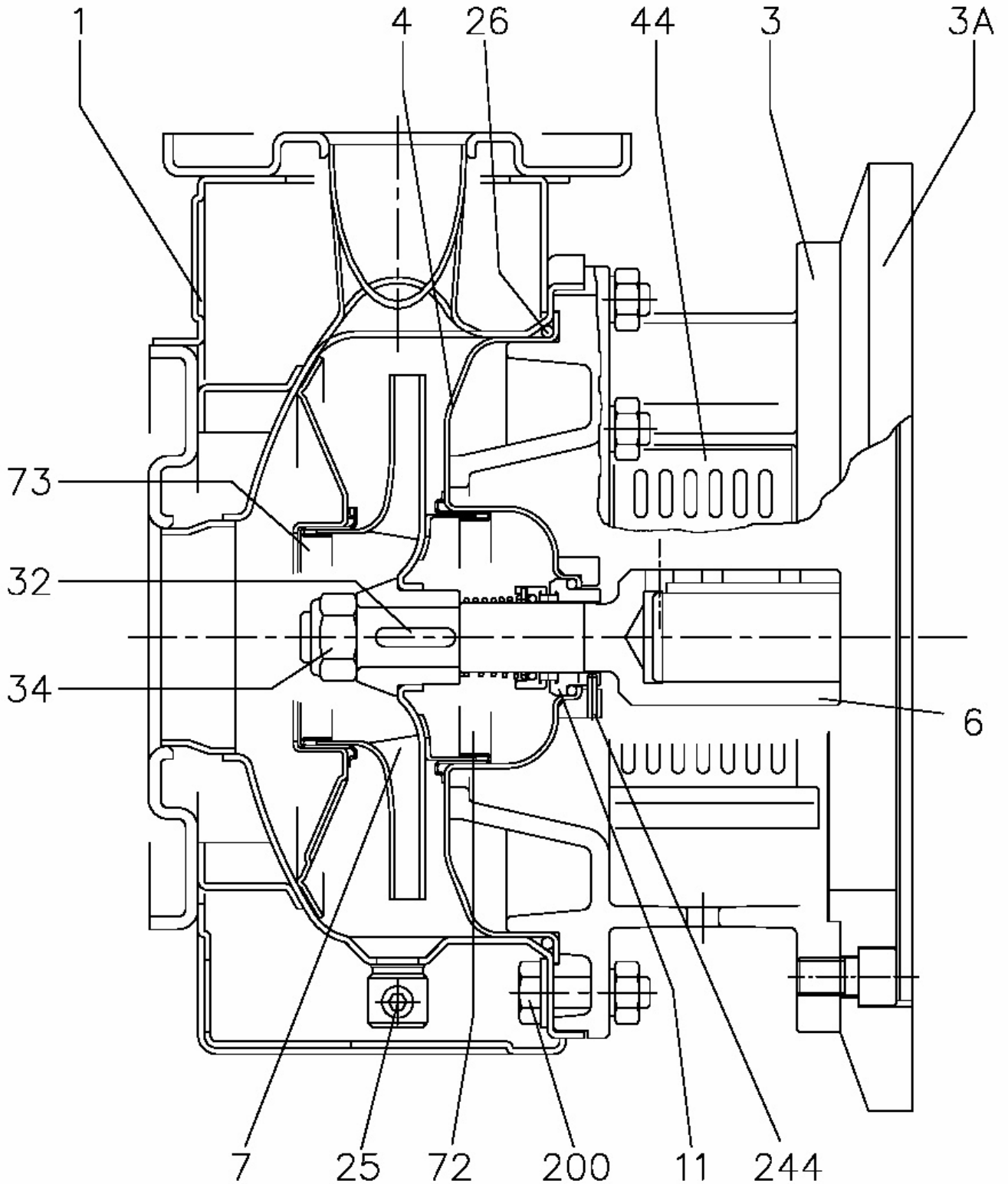

(2/3)**Construction****Pump Name 3LSF 40-200/11**

Customer	Date 10.06.2024	Company
Contact	Item no.	Issued by
Phone	Project	Phone
E-mail	Project ID	E-mail

N°	PART NAME	MATERIAL		DIMENSIONS	STANDARD	Q.TY	
		3SF	3LSF				
1	Casing	EN 1.4301 (AISI 304)	EN 1.4404 (AISI 316L)			1	
3	Motor bracket	Cast iron EN-G JL-200-EN 1561				1	
3A	Adapler ring [1]	Cast iron EN-G JL-200-EN 1561				1	
4	Casing cover	EN 1.4301 (AISI 304)	EN 1.4404 (AISI 316L)			1	
6	Coupling - Part in contact with liquid	EN 1.4301 (AISI 304)	EN 1.4404 (AISI 316L)			1	
7	Impeller	32,40,50	EN 1.4301 (AISI 304)	EN 1.4404 (AISI 316L)		1	
		65-125/160/200	EN 1.4401 (AISI 316)				
11	Mechanical seal [5]	Carbon/Ceramic/NBR	SIC/SIC/FPM			1	
25	Draing plug	EN 1.4401 (AISI 316) / PTFE		R 1/8" L=8	DIN 906	1	
26	O ring	NBR [6]	FPM	32-125, 40-125	158.11x5.34	OR 6625	1
				32-160, 40-160 , 50-125, 65-125	183.52x5.34	OR 6720	
				32-200, 40-200, 50-160, 50-200, 65-160, 65-200	227.96x5.34	OR 6895	
32	Key	EN 1.4301 (AISI 304)	EN 1.4401 (AISI 316)	Up to 11 kW	6x6x25	UNI 6604	1
				15 kW and above	8 x7x 30		
34	Impeller nut	EN 1.4301 (AISI 304)	EN 1.4404 (AISI 316L)	Up to 11kW	M16x1.5	UNI 7474	1
				50-200/15	M18x1.5		
				15 kW and above	M20x1.5		
44	Protection	EN 1.4301 (AISI 304)			EBARA DRAWING	1	
72	Casing ring [2]	EN 1.4301 (AISI 304)	EN 1.4404 (AISI 316L)			1	
73	Casing ring (not for 65 version)	EN 1.4301 (AISI 304)	EN 1.4404 (AISI 316L)			1	
200	Screw	Stainless steel A2 70 class ISO 3506/ 1		32-125, 40-125 40-160, 40-200,	M 8x30	UNI 5739	[3]
				50-125, 50-160, 50-200, 65-125, 65-160, 65-200	M 10x35	UNI 5739	
244	Pin [4]	/	EN 1.4301 (AISI 304)	4x15		1	

[1] Only for 65-125/5.5 and 65-125/7.5

[2] For version 32-200, 40-200, 50-160, 50-200

[3] Quantity=10 for 32-160, 40-160, 50-125, 65-125

Quantity=12 for 32-200, 40-200, 50-160, 50-200, 65-160, 65-200

[4] Only for 65-160/15 and 65-200

[5] FPM for H-HS-HW-HSW version

EPDM for E version, Q1AEGG, Q1U3EGG, U3CEGG, Q1Q1EGG

U3U3EGG not available for models 65-160/15 and 65-200

(3/3)

Construction

Pump Name 3LSF 40-200/11

Customer	Date 10.06.2024	Company
Contact	Item no.	Issued by
Phone	Project	Phone
E-mail	Project ID	E-mail

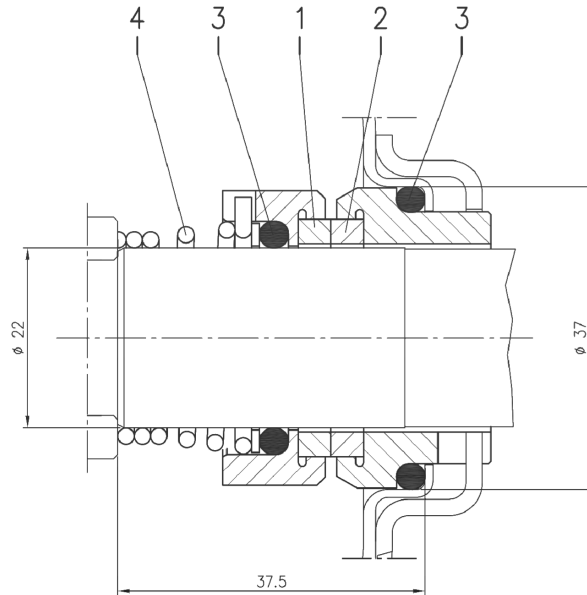

Version	Pump type	Material			
		1 Stationary seal ring	2 Rotary seal ring	3 Rubber	4 Frame + spring
L ø22	32-125/160/200 40-125/160/200 50-125/160/200 65-125 65-160/7.5-9.2-11	SiC	SiC	FPM	EN 1.4571 (AISI 316Ti)