

# Technical Data

Pump Name

3LSF 80-160/15

Customer	Date	10.06.2024	Company
Contact	Item no.		Issued by
Phone	Project		Phone
E-mail	Project ID		E-mail

## Requested data

1	Pump type	CENTRIFUGAL PUMPS	Fluid	Water
2	Number of pumps / Reserve	1 / 0	Liquid temperature	°C
3	Flow	m³/h	Kin. viscosity	cSt
4	Head	m	Vapour pressure	kPa
5	Geodetic head	m	PH value	
6	Inlet pressure (pin)	kPa	Density	kg/m³
7	Available system NPSH		Solids	Weight %
8	Ambient temperature	°C		

## Pump

9	Pump Name	3LSF 80-160/15	Frequency	Hz	50	
10	Design	CENTRIFUGAL PUMPS	Installation type		STANDARD	
11	Manufacturer	EBARA	Impeller Diameter	Max.	mm	
12	Speed	rpm		2900	Designed	mm
13	No. of Stage	1		Min.	mm	165
14	Connection	Suction side	DIN 2532	Flow	Operating	m³/h
15	Connection	Discharge side	DIN 2532		Max-	m³/h
16	Max Working Pressure	kPa	1000		Min-	m³/h
17	Shut-off head	kPa	342.42	Head	Operating	m
18	Total weight	kg	See the table of "Dimensions".		- (Qmax.)	m
19	Shaft power	kW			- (Qmin.)	m
20				Max. Shaft Power at max. impeller	kW	15.01
21	Required pump NPSH	m		Efficiency	%	

## Materials

22	Impeller	AISI 316		
23	Casing	AISI 316		
24	Shaft	AISI 316L		
25				
26				
27				

## Motor

28	Manufacturer	without motor	Insulation class	
29	Type	without motor 3	Phases	
30	Specific design	without motor / 50 Hz / Pole pairs 1	Frame size	
31	Rated power	kW	Weight	kg
32	Number of poles	2	Electric voltage	V
33	Speed	rpm	Electric current	A
34	Degree of protection			
35				

## Remarks

# Performance Curve

Pump Name

3LSF 80-160/15

Customer	Date	10.06.2024	Company
Contact	Item no.		Issued by
Phone	Project		Phone
E-mail	Project ID		E-mail

## Requested data

1	Flow	m³/h	
2	Head	m	
3	Geodetic head	m	

## Pump

Operating flow	m³/h		Frequency	Hz	50
Operating head	m		Number of poles		2
Impeller diameter designed	mm	165	Speed	rpm	2900

Test standard: ISO 9906:2012 - Grade3B

Water; 20°C; 998.3kg/m³; 1cSt

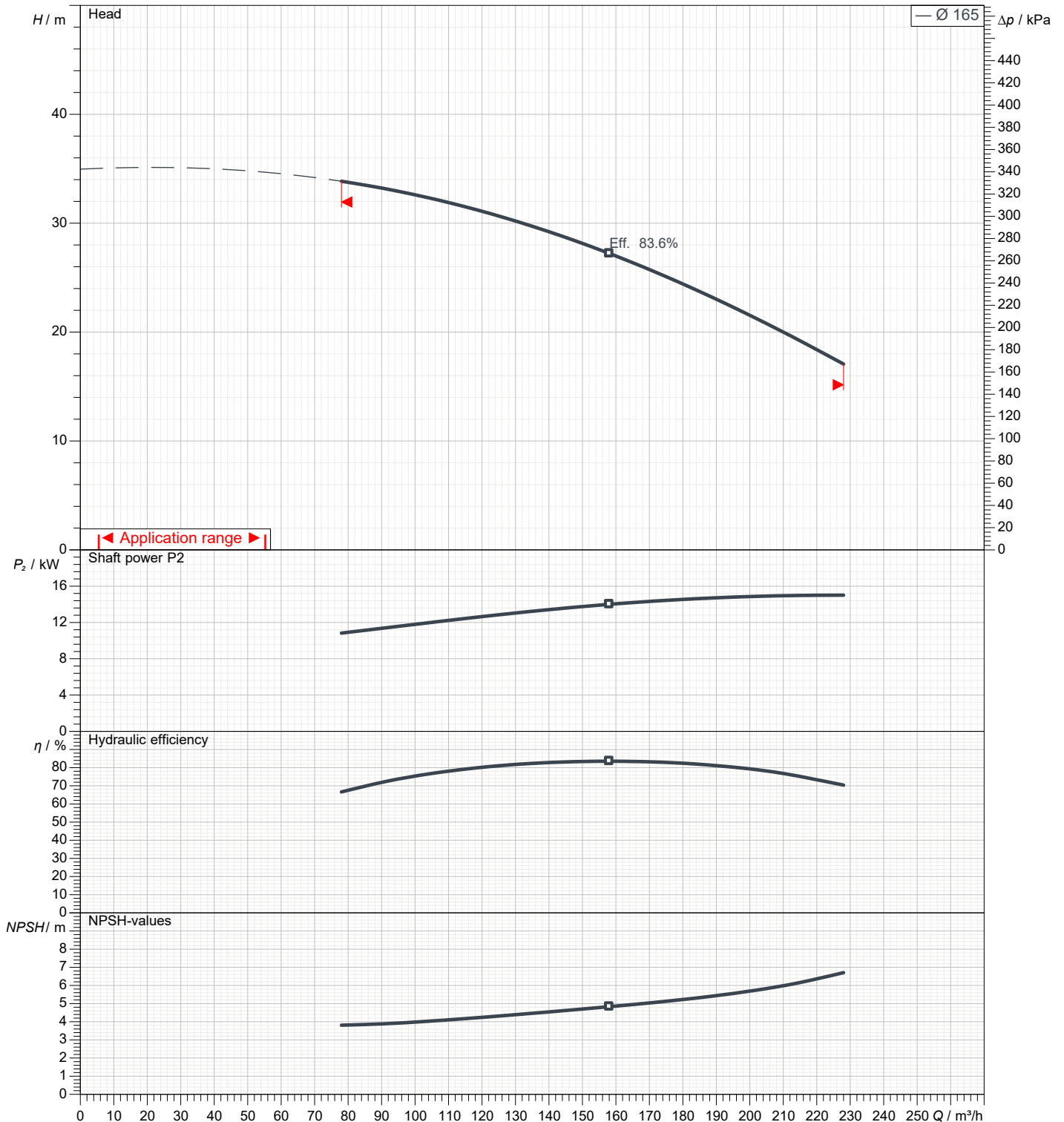

# Dimensions

Pump Name 3LSF 80-160/15

Customer	Date 10.06.2024	Company
Contact	Item no.	Issued by
Phone	Project	Phone
E-mail	Project ID	E-mail

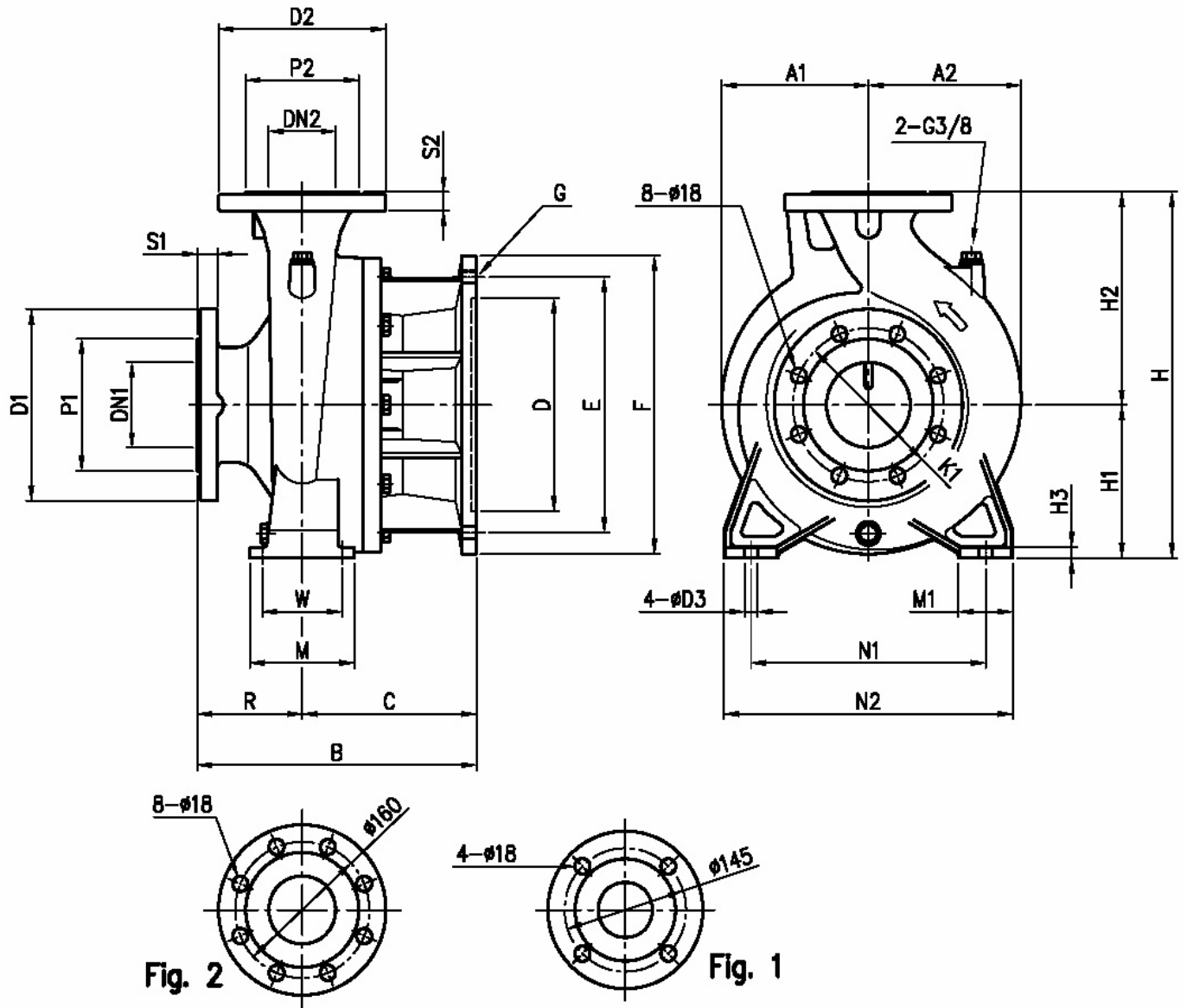

Dimensions in		mm	
1	A1	175	Fig 2
2	A2	175	4-M16
3	B	333	H
4	C	208	H1
5	D	250	H2
6	D3	15	H3
7	Dia D1	225	M
8	Dia D2	200	M1
9	Dia DN1	100	N1
10	Dia DN2	80	N2
11	Dia K1	180	R
12	Dia P1	155	S1
13	Dia P2	135	S2
14	E	300	W
15	F	350	Weight PUMP
			52 kg

(1/3)

# Construction

Pump Name 3LSF 80-160/15

Customer	Date 10.06.2024	Company
Contact	Item no.	Issued by
Phone	Project	Phone
E-mail	Project ID	E-mail

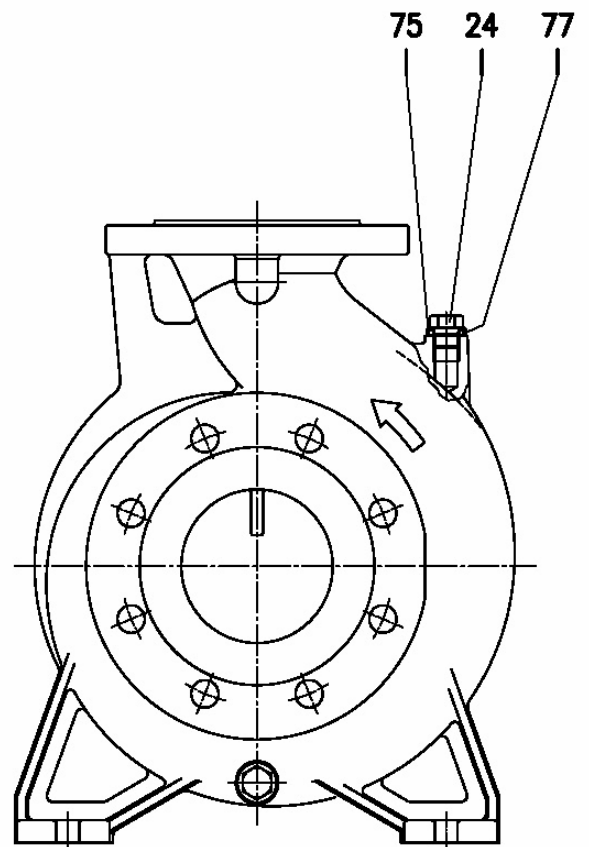
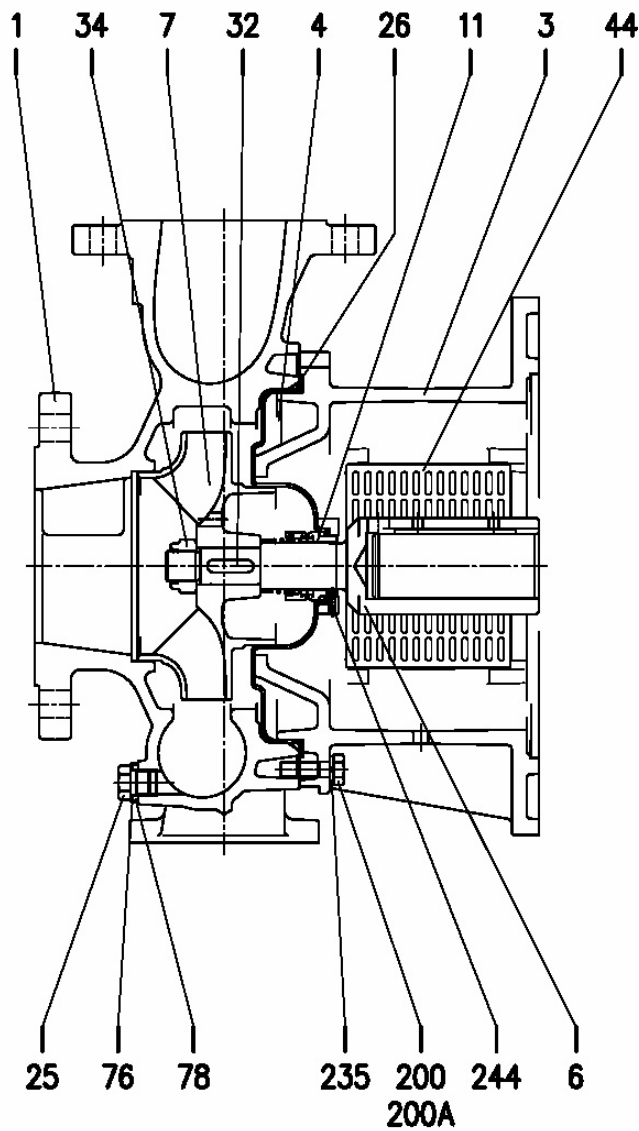

(2/3)

# Construction

Pump Name 3LSF 80-160/15

Customer	Date 10.06.2024	Company
Contact	Item no.	Issued by
Phone	Project	Phone
E-mail	Project ID	E-mail

N°	PART NAME	MATERIAL	DIMENSIONS	STANDARD	Q.TY
1	Casing	EN 1.4401 (AISI 316)			1
3	Motor bracket	Cast iron EN-GJL-200-EN 1561			1
4	Casing cover	EN 1.4404 (AISI 316L)			1
6	Coupling	EN 1.4404 (AISI 316L)			1
7	Impeller	EN 1.4401 (AISI 316)			1
11	Mechanical seal [2]	SiC/SiC/FPM			1
24	Plug	EN 1.4404 (AISI 316L)	G3/8	EPE DRAWING	1
25	Plug	EN 1.4404 (AISI 316L)	G3/8	EPE DRAWING	1
26	"O" ring	FPM [3]	227.96x5.34	OR 6895	1
32	Key	EN 1.4401 (AISI 316)	8x7x30	UNI 6604	1
34	Impeller nut	EN 1.4404 (AISI 316L)	M20x1.5	UNI 7474	1
44	Protection	EN 1.4301 (AISI 304)		EPE DRAWING	2
75	Washer (plug)	EN 1.4404 (AISI 316L)			1
76	Washer (plug)				1
77	O-ring (plug)	FPM			1
78	O-ring (plug)	EPDM (E option)			1
200	Screw	Stainless steel A2-70	M 10x35	UNI 5739	10
200A	Screw	class ISO 3506/1	M 10x30		2
235	Washer	EN 1.4301(AISI 304)	10.5	UNI 8842	12
244	Pin [1]	EN 1.4301(AISI 304)	4x15		1

[1] Not for H and E option

[2] Special version: see **CONSTRUCTION 3**

[3] FPM for H-HW-HSW version

EPDM for E version, Q1Q1EGG, Q1U3EGG, U3CEGG, Q1AEGG

(3/3)

# Construction

Pump Name 3LSF 80-160/15

Customer	Date 10.06.2024	Company
Contact	Item no.	Issued by
Phone	Project	Phone
E-mail	Project ID	E-mail

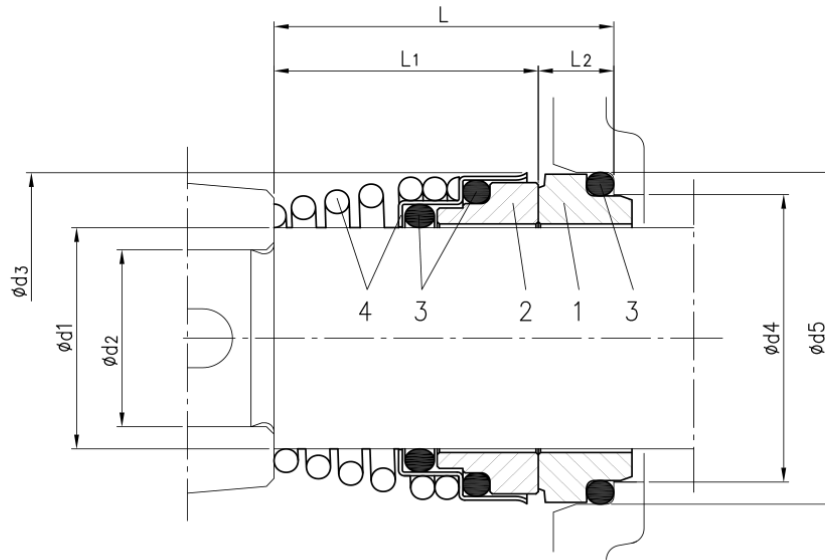

Version	Pump type	Dimensions									Material			
		d1	d2	d3	d4	d5	L	L1	L2	1 Stationary seal ring	2 Rotary seal ring	3 Rubber	4 Frame + spring	
L ø30	65-160/15 65-200/250 80-160/200	30	24	44	39	45	42.5	31	11.5	SiC	SiC	FPM	EN 1.4571 (AISI 316Ti)	
L ø35	80-250	35	29	49	44	50	42.5	31	11.5	SiC	SiC	FPM	EN 1.4571 (AISI 316Ti)	