

Technical Data

Pump Name

3LS 50-200/9.2

Customer	Date	10.06.2024	Company
Contact	Item no.		Issued by
Phone	Project		Phone
E-mail	Project ID		E-mail

Requested data

1	Pump type	CENTRIFUGAL PUMPS	Fluid	Water
2	Number of pumps / Reserve	1 / 0	Liquid temperature	°C
3	Flow	m³/h	Kin. viscosity	cSt
4	Head	m	Vapour pressure	kPa
5	Geodetic head	m	PH value	
6	Inlet pressure (pin)	kPa	Density	kg/m³
7	Available system NPSH		Solids	Weight %
8	Ambient temperature	°C		

Pump

9	Pump Name	3LS 50-200/9.2	Frequency	Hz	50	
10	Design	CENTRIFUGAL PUMPS	Installation type		STANDARD	
11	Manufacturer	EBARA	Impeller Diameter	Max.	mm	
12	Speed	rpm		2900	Designed	mm
13	No. of Stage	1		Min.	mm	191
14	Connection	Suction side	DIN 2532	Flow	Operating	m³/h
15	Connection	Discharge side	DIN 2532		Max-	m³/h
16	Max Working Pressure	kPa	1000		Min-	m³/h
17	Shut-off head	kPa	519.04	Head	Operating	m
18	Total weight	kg	See the table of "Dimensions".		- (Qmax.)	m
19	Shaft power	kW			- (Qmin.)	m
20				Max. Shaft Power at max. impeller	kW	9.30
21	Required pump NPSH	m		Efficiency	%	

Materials

22	Impeller	AISI 316L		
23	Casing	AISI 316L		
24	Shaft	AISI 316L		
25				
26				
27				

Motor

28	Manufacturer	LAFERT	Insulation class	F	
29	Type	TEFC_3S50-200/9.2_400_Three Phase	Phases	3~	
30	Specific design	IE3 / 50 Hz / Pole pairs 1	Frame size	132 M	
31	Rated power	kW	9.2	Weight	kg
32	Number of poles	2	Electric voltage	V	400
33	Speed	rpm	2900	Electric current	A
34	Degree of protection				
35					

Remarks

Performance Curve

Pump Name

3LS 50-200/9.2

Customer	Date	10.06.2024	Company
Contact	Item no.		Issued by
Phone	Project		Phone
E-mail	Project ID		E-mail

Requested data

1	Flow	m³/h	
2	Head	m	
3	Geodetic head	m	

Pump

Operating flow	m³/h		Frequency	Hz	50
Operating head	m		Number of poles		2
Impeller diameter designed	mm	191	Speed	rpm	2900

Test standard: ISO 9906:2012 - Grade3B

Water; 20°C; 998.3kg/m³; 1cSt

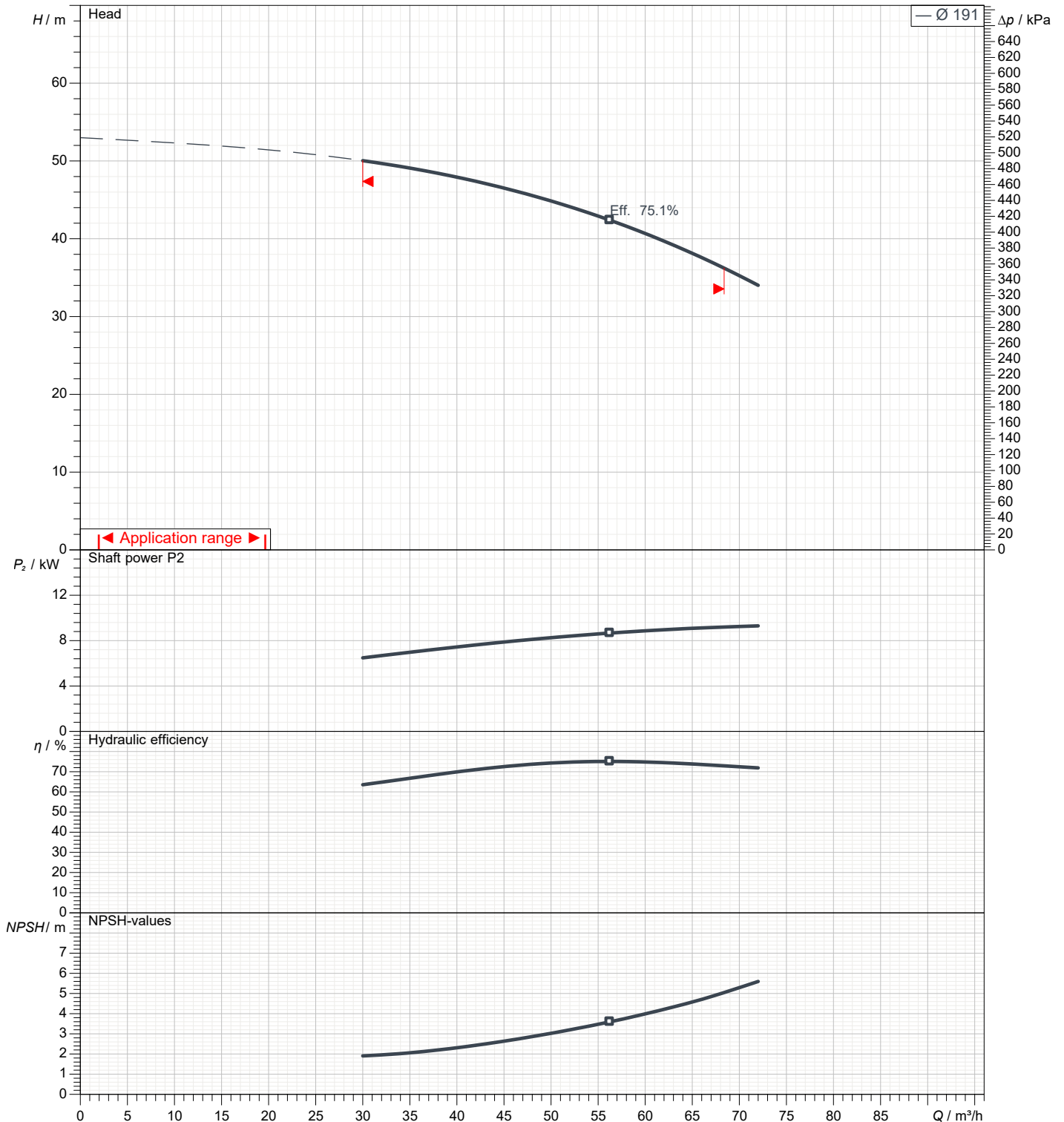

Dimensions

Pump Name 3LS 50-200/9.2

Customer	Date 10.06.2024	Company
Contact	Item no.	Issued by
Phone	Project	Phone
E-mail	Project ID	E-mail

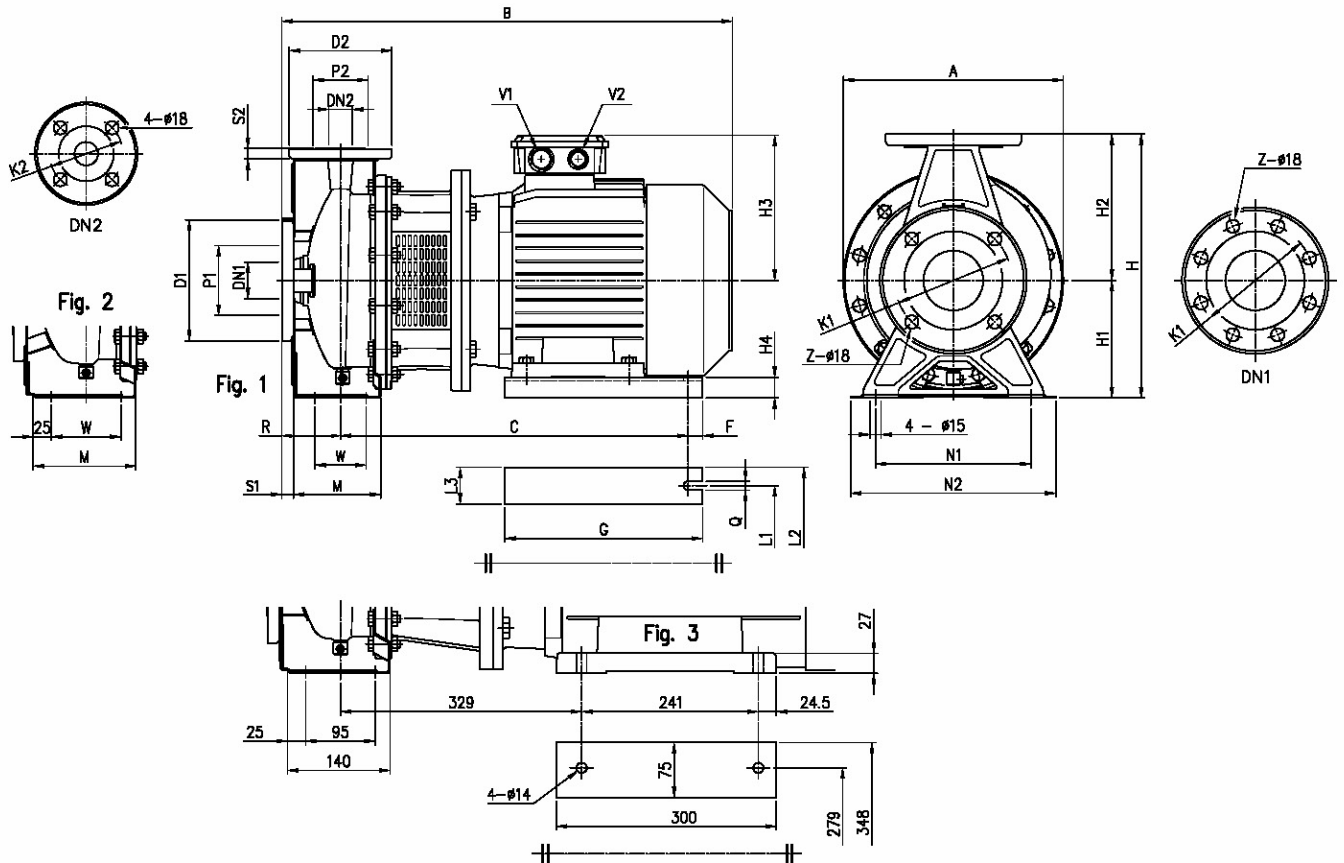

Dimensions in		mm					
1	A	300	H2	200	W	70	
2	B	667	H3	198	Weight P&M	90,7 kg	
3	C	479	H4	28	Z	4	
4	Dia D1	185	L1	216			
5	Dia D2	165	L2	266			
6	Dia DN1	65	L3	50			
7	Dia DN2	50	M	115			
8	Dia K1	145	N1	212			
9	Dia K2	125	N2	265			
10	Dia P1	115	Q	12			
11	Dia P2	95	R	100			
12	F	15	S1	16			
13	G	270	S2	16			
14	H	360	V1	[M32x1].5			
15	H1	160	V2	[M32x1].5			

(1/3)

Construction

Pump Name 3LS 50-200/9.2

Customer	Date 10.06.2024	Company
Contact	Item no.	Issued by
Phone	Project	Phone
E-mail	Project ID	E-mail

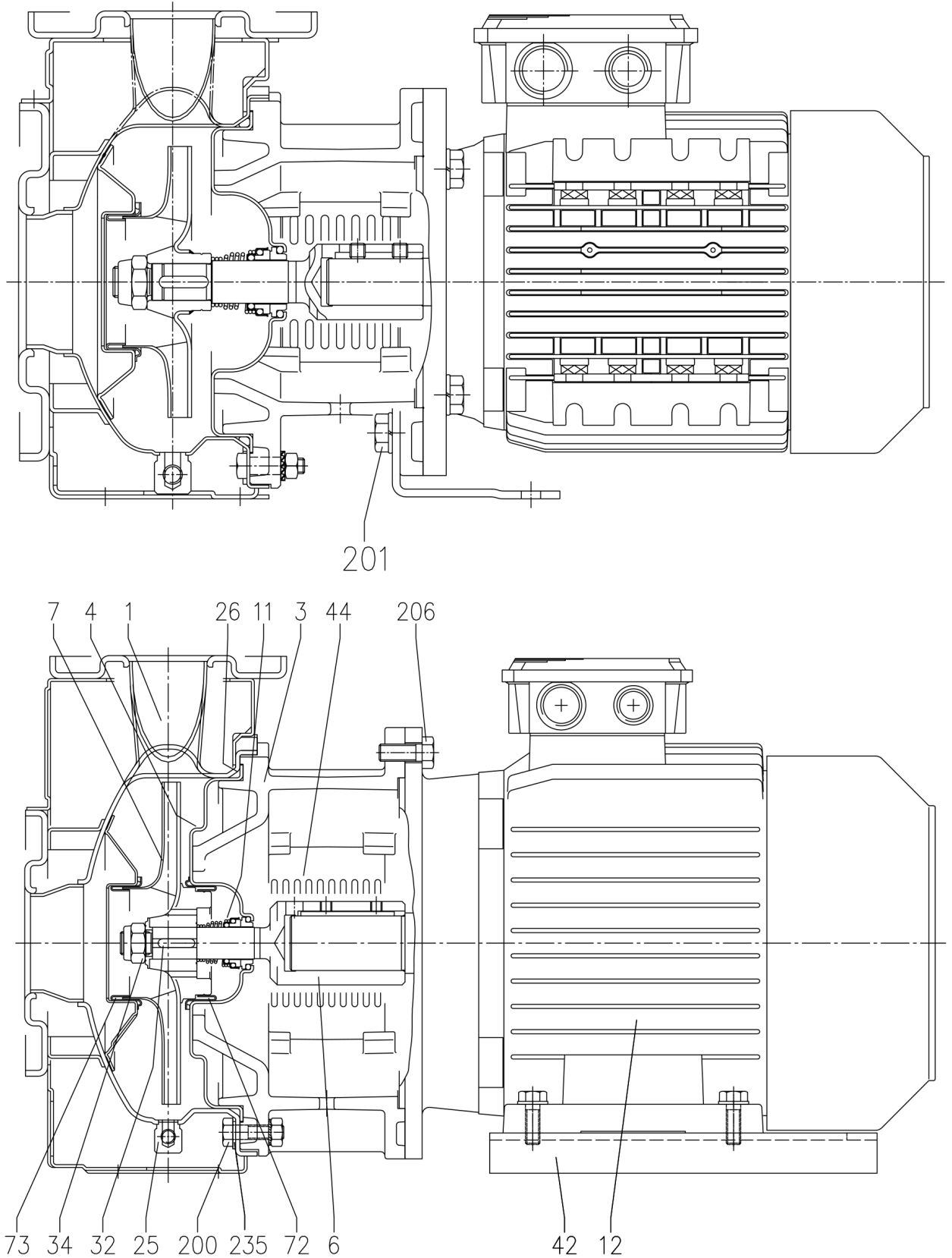

(2/3)

Construction

Pump Name 3LS 50-200/9.2

Customer	Date 10.06.2024	Company
Contact	Item no.	Issued by
Phone	Project	Phone
E-mail	Project ID	E-mail

N°	PART NAME	MATERIAL		DIMENSIONS	STANDARD	Q.TY	
		3S	3LS				
1	Casing	EN 1.4301 (AISI 304)	EN 1.4404 (AISI 316L)			1	
3	Motor bracket	Cast iron EN-GJL-200-EN 1561				1	
3 A	Adapter ring	Cast iron EN-GJL-200-EN 1561				1	
4	Casing cover	EN 1.4301 (AISI 304)	EN 1.4404 (AISI 316L)			1	
6	Coupling - Part in contact with liquid	EN 1.4301 (AISI 304)	EN 1.4404 (AISI 316L)			1	
7	Impeller	EN 1.4301 (AISI 304)	EN 1.4404 (AISI 316L) [9]			1	
11	Mechanical seal	Carbon/Ceramic/NBR	SiC/SiC/FPM	[7]		1	
12	Motor	-				1	
25	Draing plug	EN 1.4401 (AISI 316) / PTFE		R 1/8" L=8	DIN 906	1	
26	"O" ring	32-125, 40-125	NBR [8]	FPM	158.11x5.34	OR 6625	1
		32-160, 40-160, 50-125, 65-125			183.52x5.34	OR 6720	
		32-200, 40-200, 50-160, 50-200, 65-160, 65-200			227.96x5.34	OR 6895	
32	Key	Up to 11 kW	EN 1.4401 (AISI 316)		6x6x25	UNI 6604	1
		15 kW and above	8x7x30				
34	Impeller nut	Up to 11kW	EN 1.4301 (AISI 304)	EN 1.4404 (AISI 316L)	M16x1.5	UNI 7474	1
		50-200/15			M18x1.5		
		15 kW and above			M20x1.5		
42	Foot	Aluminium / Galvanized steel				[2]	
44	Protection	EN 1.4301 (AISI 304)			EBARA DRAWING	1	
72	Casing ring	EN 1.4301 (AISI 304)	EN 1.4404 (AISI 316L)			1	
73	Casing ring (not for 65 version)	EN 1.4301 (AISI 304)	EN 1.4404 (AISI 316L)			1	
200	Screw	32-125, 40-125	Stainless steel A2 70 class ISO 3506/1		M 8x30	UNI 5739	8
		50-200, 65-125, 65-160, 65-200	M 10x35	UNI 5739	[4]		
201	Screw	Galvanized Steel 8.8 strenght class ISO 898/1		M 10x16	UNI 5739	[5]	
206	Screw for bracket	Galvanized Steel 8.8 strenght class ISO 898/1		M 10x40	UNI 5739	4	
206-2	Screw adapter ring	Galvanized Steel 8.8 strenght class ISO 898/1			UNI 5931	4	
235	Washer	32-125, 40-125	Stainless steel A2 70 class ISO 3506/1		M 8.4x17	UNI 6592	8
		50-200, 65-125, 65-160, 65-200	M 10.5x21	UNI 6592	[4]		
244	Pin	-	EN 1.4301 (AISI 304)		UNI 5931	4	

[1] Only for version 65-125/5.5 and 65-125/7.5

[2] Quantity =0 for version 65-200/22

Quantity =1 for version for 32, 40, 50, 65-125/5.5, 65-125/7.5, 65-160/11, 65-160/15, 65-200/15, 65-200/18.5

Quantity =2 for version for 65-125/4, 65-160/7.5, 65-160/9.2

[3] Only for version 32-200, 40-200, 50-160, 50-200

[4] Quantity =10 for 32-160, 40-160, 50-125, 65-125

Quantity =12 for 32-200, 40-200, 50-160, 50-200, 65-160, 65-200

[5] Only for version 32-125/1.1, 32-160/1.5, 32-160/1.5, 32-160/2.2, 40-125/1.5, 40-125/2.2, 50-125/2.2

[6] Only for 65-160/15, 65-200

[7] Special version: see CONSTRUCTION 3

[8] PM for H-HS-HW-HSW version

EPDM for E version, Q1AEGG, U3U3EGG, Q1Q1EGG, Q1U3EGG, U3CEGG

U3U3EGG not available for 65-150/15 and 65-200

[9] CF8M – EN 1.4408 (AISI316) material for 65-125 up to 65-200

(3/3)

Construction

Pump Name 3LS 50-200/9.2

Customer	Date 10.06.2024	Company
Contact	Item no.	Issued by
Phone	Project	Phone
E-mail	Project ID	E-mail

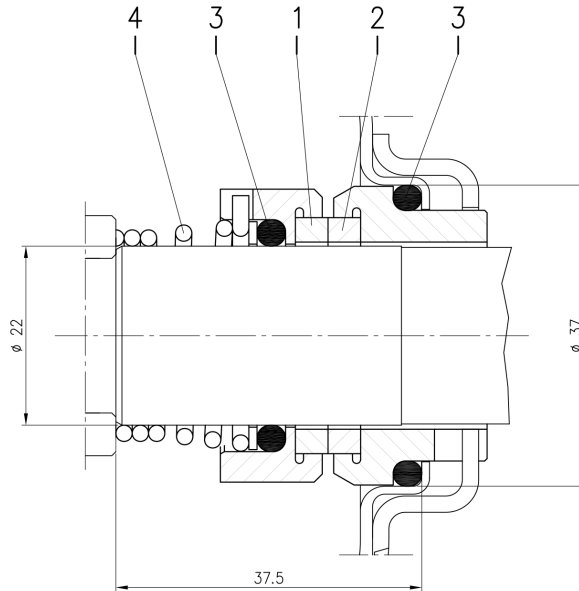

Version	Pump type	Material			
		1 Stationary seal ring	2 Rotary seal ring	3 Rubber	4 Frame + spring
L $\phi 22$	32-125/160/200 40-125/160/200 50-125/160/200 65-125 65-160/7.5-9.2-11	SiC	SiC	FPM	EN 1.4571 (AISI 316Ti)