

Technical Data

Pump Name

3LS 65-160/15

Customer	Date	10.06.2024	Company
Contact	Item no.		Issued by
Phone	Project		Phone
E-mail	Project ID		E-mail

Requested data

1	Pump type	CENTRIFUGAL PUMPS	Fluid	Water
2	Number of pumps / Reserve	1 / 0	Liquid temperature	°C 20
3	Flow m³/h		Kin. viscosity	cSt 1.005
4	Head m		Vapour pressure	kPa 2.34
5	Geodetic head m		PH value	
6	Inlet pressure (pin) kPa	0	Density	kg/m³ 998.3
7	Available system NPSH		Solids	Weight % 0
8	Ambient temperature °C	20		

Pump

9	Pump Name	3LS 65-160/15	Frequency	Hz 50
10	Design	CENTRIFUGAL PUMPS	Installation type	STANDARD
11	Manufacturer	EBARA	Impeller Diameter	Max. mm 178
12	Speed rpm	2900		Designed mm 178
13	No. of Stage	1		Min. mm 178
14	Connection Suction side	DIN 2532	Flow	Operating m³/h
15	Connection Discharge side	DIN 2532		Max- m³/h 138
16	Max Working Pressure kPa	1000		Min- m³/h 42
17	Shut-off head kPa	470.08	Head	Operating m
18	Total weight kg	See the table of "Dimensions".		- (Qmax.) m 26.5
19	Shaft power kW			- (Qmin.) m 45.5
20			Max. Shaft Power at max. impeller	kW 13.68
21	Required pump NPSH m		Efficiency	%

Materials

22	Impeller	CF8M		
23	Casing	AISI 316L		
24	Shaft	AISI 316L		
25				
26				
27				

Motor

28	Manufacturer	LAFERT	Insulation class	F
29	Type	TEFC_3S65-160/15_400_Three Phase	Phases	3~
30	Specific design	IE3 / 50 Hz / Pole pairs 1	Frame size	160 M
31	Rated power kW	15	Weight	kg 88.91
32	Number of poles	2	Electric voltage	V 400
33	Speed rpm	2900	Electric current	A 26.7
34	Degree of protection			
35				

Remarks

Performance Curve

Pump Name

3LS 65-160/15

Customer	Date 10.06.2024	Company
Contact	Item no.	Issued by
Phone	Project	Phone
E-mail	Project ID	E-mail

Requested data

1	Flow	m³/h	
2	Head	m	
3	Geodetic head	m	

Pump

Operating flow	m³/h	Frequency	Hz	50	
Operating head	m	Number of poles		2	
Impeller diameter designed	mm	178	Speed	rpm	2900

Test standard: ISO 9906:2012 - Grade3B

Water; 20°C; 998.3kg/m³; 1cSt

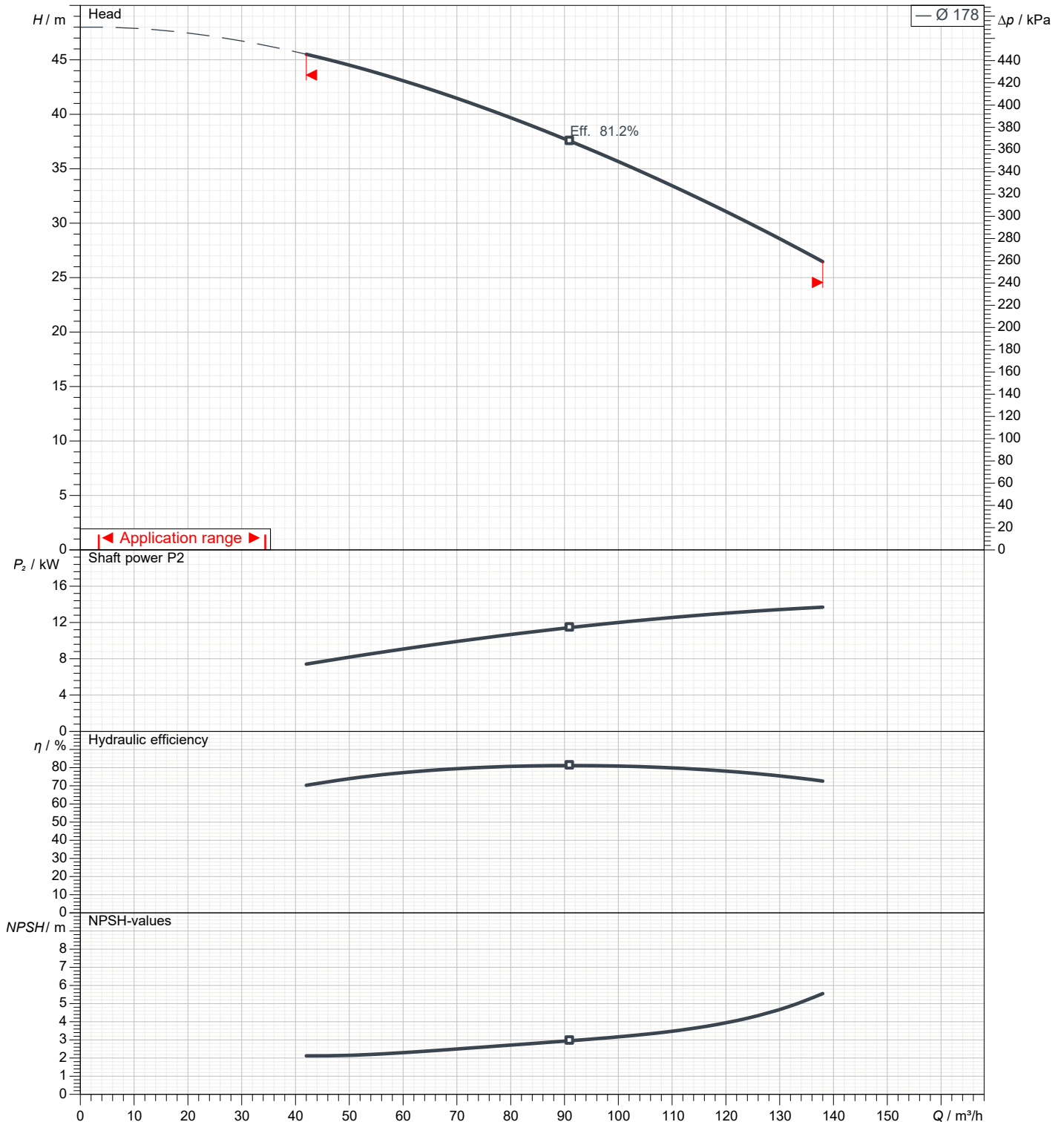

Dimensions

Pump Name 3LS 65-160/15

Customer	Date 10.06.2024	Company
Contact	Item no.	Issued by
Phone	Project	Phone
E-mail	Project ID	E-mail

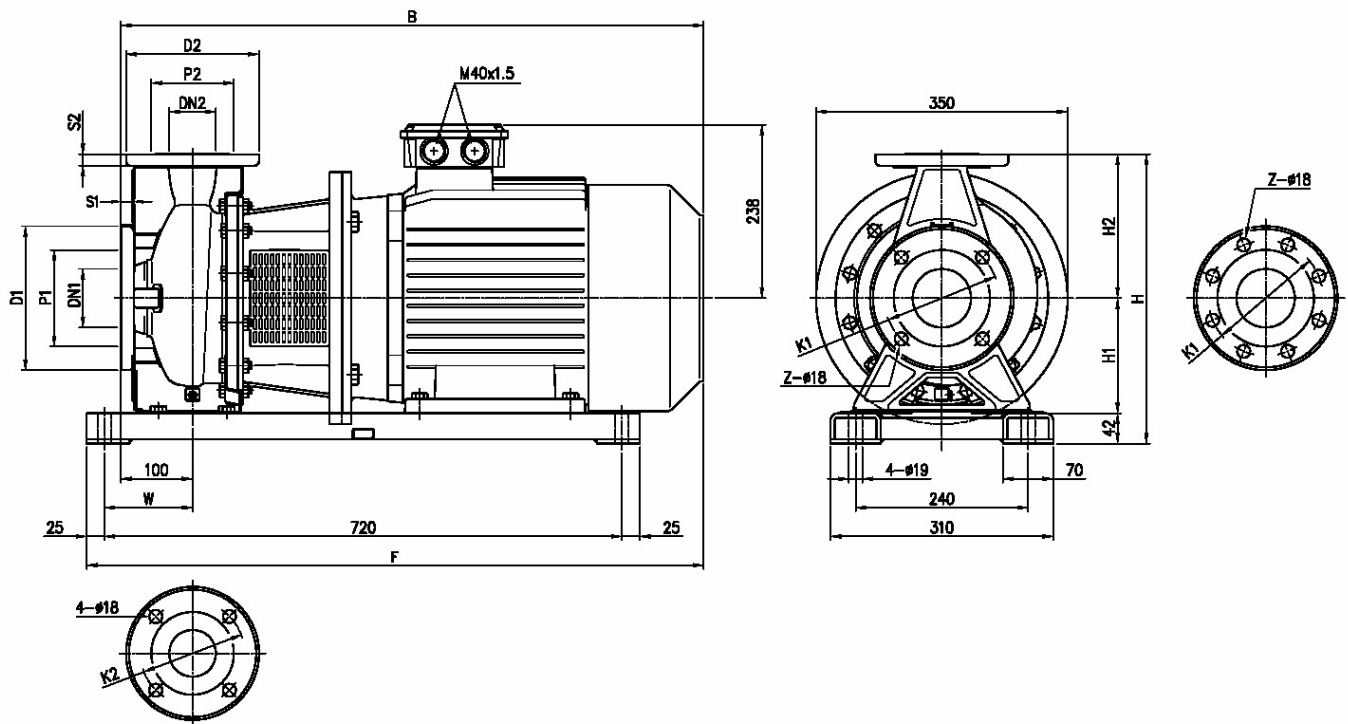

Dimensions in		mm						
1	B	806	W	122.5				
2	Dia D1	200	Weight P&M	120,9 kg				
3	Dia D2	185	Z	8				
4	Dia DN1	80	Z option	4				
5	Dia DN2	65						
6	Dia K1	160						
7	Dia K2	145						
8	Dia P1	134						
9	Dia P2	115						
10	F	854						
11	H	402						
12	H1	160						
13	H2	200						
14	S1	18						
15	S2	16						

(1/3)

Construction

Pump Name 3LS 65-160/15

Customer	Date 10.06.2024	Company
Contact	Item no.	Issued by
Phone	Project	Phone
E-mail	Project ID	E-mail

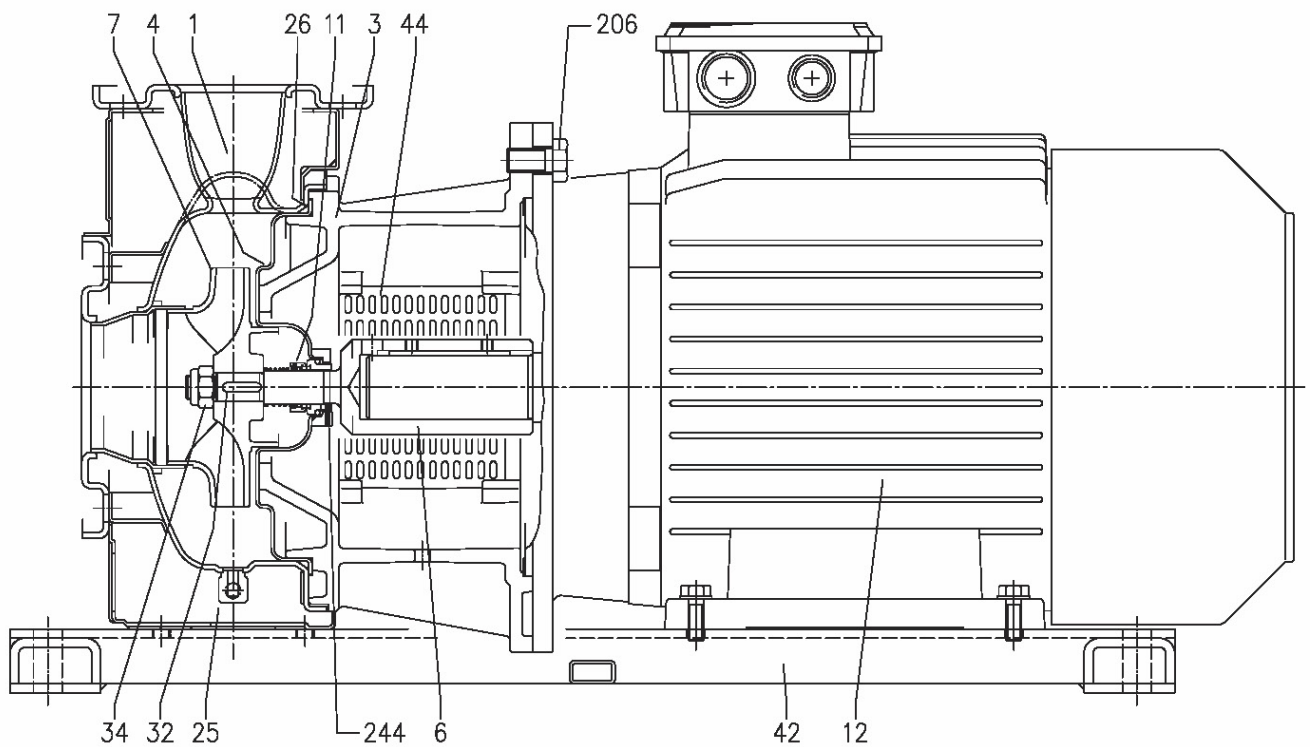
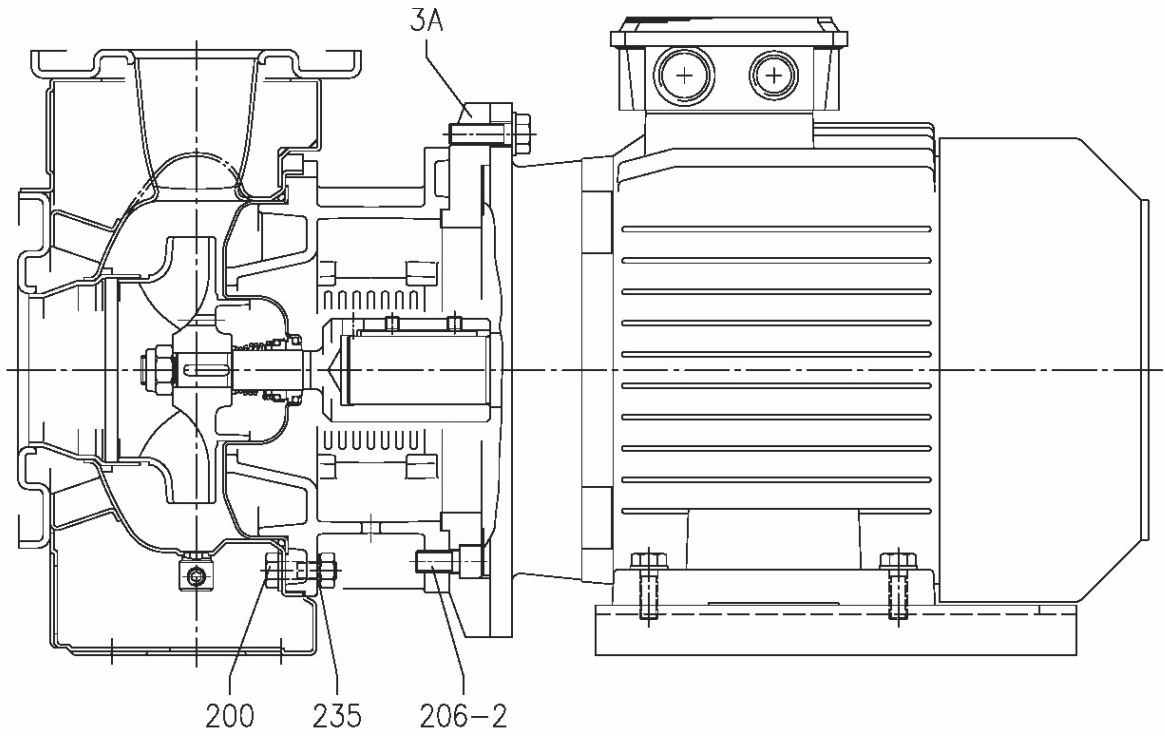

(2/3)

Construction

Pump Name 3LS 65-160/15

Customer	Date 10.06.2024	Company
Contact	Item no.	Issued by
Phone	Project	Phone
E-mail	Project ID	E-mail

N°	PART NAME	MATERIAL		DIMENSIONS	STANDARD	Q.TY
		3S	3LS			
1	Casing	EN 1.4301 (AISI 304)	EN 1.4404 (AISI 316L)			1
3	Motor bracket	Cast iron EN-GJL-200-EN 1561				1
3 A	Adapter ring	Cast iron EN-GJL-200-EN 1561				1
4	Casing cover	EN 1.4301 (AISI 304)	EN 1.4404 (AISI 316L)			1
6	Coupling - Part in contact with liquid	EN 1.4301 (AISI 304)	EN 1.4404 (AISI 316L)			1
7	Impeller	EN 1.4301 (AISI 304)	EN 1.4404 (AISI 316L) [9]			1
11	Mechanical seal	Carbon/Ceramic/NBR	SiC/SiC/FPM	[7]		1
12	Motor	-				1
25	Draing plug	EN 1.4401 (AISI 316) / PTFE		R 1/8" L=8	DIN 906	1
26	"O" ring	NBR [8]	FPM	32-125, 40-125	158.11x5.34	OR 6625
				32-160, 40-160, 50-125, 65-125	183.52x5.34	OR 6720
				32-200, 40-200, 50-160, 50-200, 65-160, 65-200	227.96x5.34	OR 6895
32	Key	EN 1.4401 (AISI 316)		6x6x25	UNI 6604	1
				8x7x30		
34	Impeller nut	EN 1.4301 (AISI 304)	EN 1.4404 (AISI 316L)	Up to 11kW	UNI 7474	1
				50-200/15		
				15 kW and above		
42	Foot	Aluminium / Galvanized steel				[2]
44	Protection	EN 1.4301 (AISI 304)			EBARA DRAWING	1
72	Casing ring	EN 1.4301 (AISI 304)	EN 1.4404 (AISI 316L)			1
73	Casing ring (not for 65 version)	EN 1.4301 (AISI 304)	EN 1.4404 (AISI 316L)			1
200	Screw	Stainless steel A2 70 class ISO 3506/1		M 8x30	UNI 5739	8
				M 10x35	UNI 5739	[4]
201	Screw	Galvanized Steel 8.8 strenght class ISO 898/1		M 10x16	UNI 5739	[5]
206	Screw for bracket	Galvanized Steel 8.8 strenght class ISO 898/1		M 10x40	UNI 5739	4
206-2	Screw adapter ring	Galvanized Steel 8.8 strenght class ISO 898/1			UNI 5931	4
235	Washer	Stainless steel A2 70 class ISO 3506/1		M 8.4x17	UNI 6592	8
				M 10.5x21	UNI 6592	[4]
244	Pin	-	EN 1.4301 (AISI 304)		UNI 5931	4

[1] Only for version 65-125/5.5 and 65-125/7.5

[2] Quantity =0 for version 65-200/22

Quantity =1 for version for 32, 40, 50, 65-125/5.5, 65-125/7.5, 65-160/11, 65-160/15, 65-200/15, 65-200/18.5

Quantity =2 for version for 65-125/4, 65-160/7.5, 65-160/9.2

[3] Only for version 32-200, 40-200, 50-160, 50-200

[4] Quantity =10 for 32-160, 40-160, 50-125, 65-125

Quantity =12 for 32-200, 40-200, 50-160, 50-200, 65-160, 65-200

[5] Only for version 32-125/1.1, 32-160/1.5, 32-160/1.5, 32-160/2.2, 40-125/1.5, 40-125/2.2, 50-125/2.2

[6] Only for 65-160/15, 65-200

[7] Special version: see CONSTRUCTION 3

[8] PM for H-HS-HW-HSW version

EPDM for E version, Q1AEGG, U3U3EGG, Q1Q1EGG, Q1U3EGG, U3CEGG

U3U3EGG not available for 65-150/15 and 65-200

[9] CF8M – EN 1.4408 (AISI316) material for 65-125 up to 65-200

(3/3)

Construction

Pump Name 3LS 65-160/15

Customer	Date 10.06.2024	Company
Contact	Item no.	Issued by
Phone	Project	Phone
E-mail	Project ID	E-mail

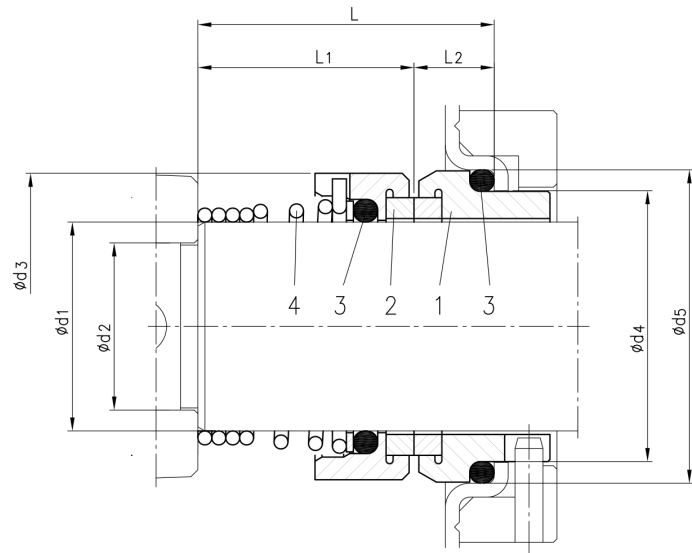

Version	Pump type	Dimensions								Material			
		d1	d2	d3	d4	d5	L	L1	L2	1 Stationary seal ring	2 Rotary seal ring	3 Rubber	4 Frame + spring
L ϕ 30	65-160/15 65-200/250 80-160/200	30	24	44	39	45	42.5	31	11.5	SiC	SiC	FPM	EN 1.4571 (AISI 316Ti)
L ϕ 35	80-250	35	29	49	44	50	42.5	31	11.5				