

Technical Data

Pump Name

3M4 40-200/1.1

Customer	Date	2024-06-12	Company
Contact	Item no.		Issued by
Phone	Project		Phone
E-mail	Project ID	Proiect redenumit 2024-06-12 12:10:37	E-mail

Requested data

1	Pump type	CENTRIFUGAL PUMPS	Fluid	Water	
2	Number of pumps / Reserve	1 / 0	Liquid temperature	°C	20
3	Flow	m³/h	Kin. viscosity	mm²/s	1.005
4	Head	m	Vapour pressure	bar	0.0234
5	Geodetic head	m	PH value		
6	Inlet pressure (pin)	bar	Density	kg/m³	998.3
7	Available system NPSH		Solids	Weight %	0
8	Ambient temperature	°C	20		

Pump

9	Pump Name	3M4 40-200/1.1	Frequency	Hz	50		
10	Design	CENTRIFUGAL PUMPS	Installation type		STANDARD		
11	Manufacturer	EBARA	Impeller Diameter	Max.	mm	200	
12	Speed	rpm		1400	Designed	mm	200
13	No. of Stage	1		Min.	mm	200	
14	Connection	Suction side	DIN 2532	Flow	Operating	m³/h	
15	Connection	Discharge side	DIN 2532		Max-	m³/h	21
16	Max Working Pressure	bar	10		Min-	m³/h	6
17	Shut-off head	bar	1.33	Head	Operating	m	
18	Total weight	kg	See the table of "Dimensions".		- (Qmax.)	m	9.6
19	Shaft power	kW			- (Qmin.)	m	13.2
20				Max. Shaft Power at max. impeller	kW	0.80	
21	Required pump NPSH	m		Efficiency	%		

Materials

22	Impeller	AISI 304		
23	Casing	AISI 304		
24	Shaft	AISI 304		
25				
26				
27				

Motor

28	Manufacturer	EPE Standard	Insulation class	F		
29	Type	TEFC_3M440-200/1.1_230_Three Phase	Phases	3~		
30	Specific design	IE3 / 50 Hz / Pole pairs 2	Frame size	90		
31	Rated power	kW	1.1	Weight	kg	
32	Number of poles	4	Electric voltage	V	230	
33	Speed	rpm	1400	Electric current	A	4.6
34	Degree of protection	IP 55				
35						

Remarks

--

Performance Curve

Pump Name

3M4 40-200/1.1

Customer	Date	2024-06-12	Company
Contact	Item no.		Issued by
Phone	Project		Phone
E-mail	Project ID	Proiect redenumit 2024-06-12 12:10:37	E-mail

Requested data

1	Flow	m³/h	
2	Head	m	
3	Geodetic head	m	

Pump

Operating flow	m³/h		Frequency	Hz	50
Operating head	m		Number of poles		4
Impeller diameter designed	mm	200	Speed	rpm	1400

Test standard: ISO 9906:2012 - Grade3B

Water; 20°C; 998.3kg/m³; 1mm²/s

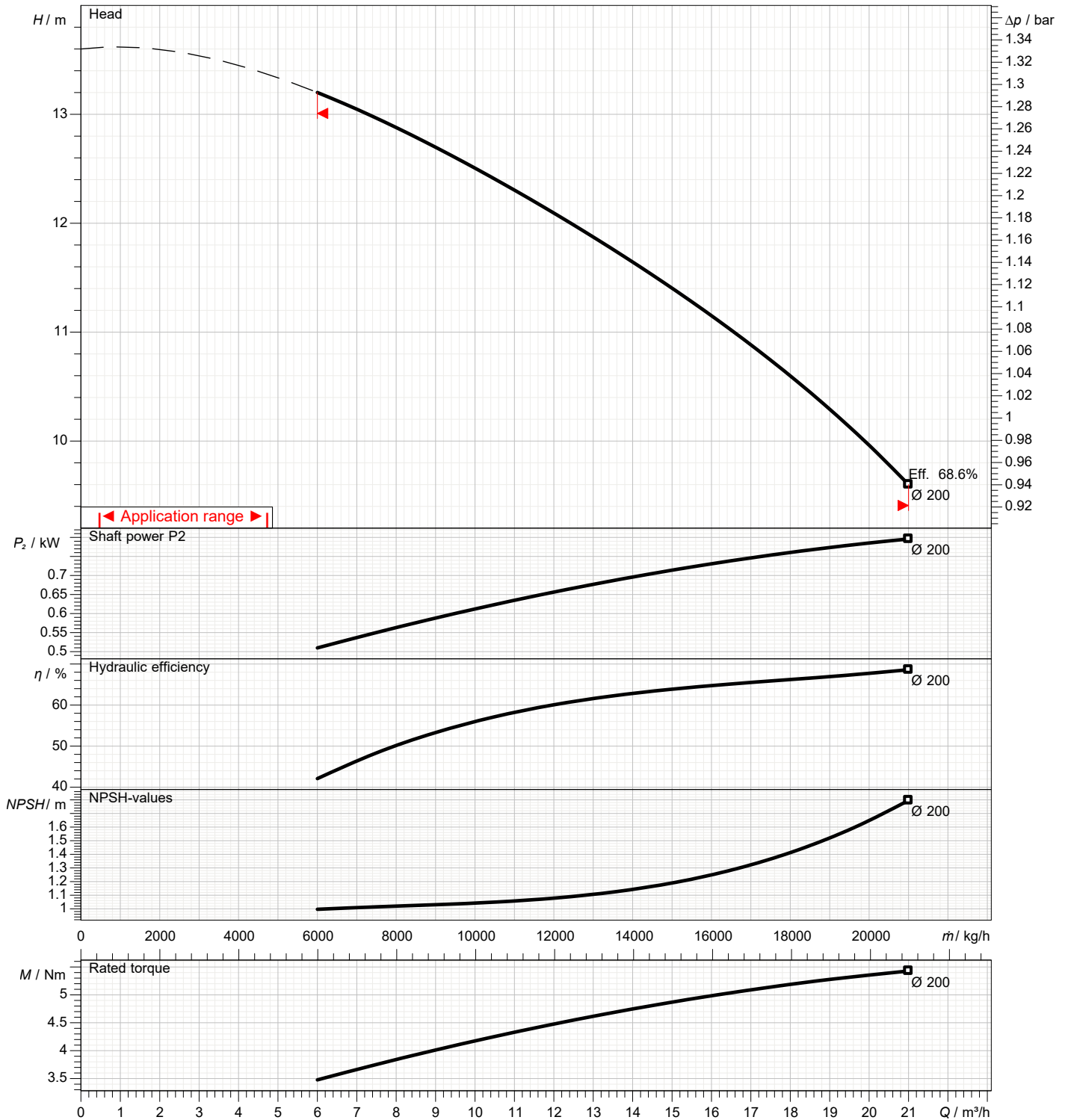

Dimensions

Pump Name 3M4 40-200/1.1

Customer	Date 2024-06-12	Company
Contact	Item no.	Issued by
Phone	Project	Phone
E-mail	Project ID Proiect redenumit 2024-06-12 12:10:37	E-mail

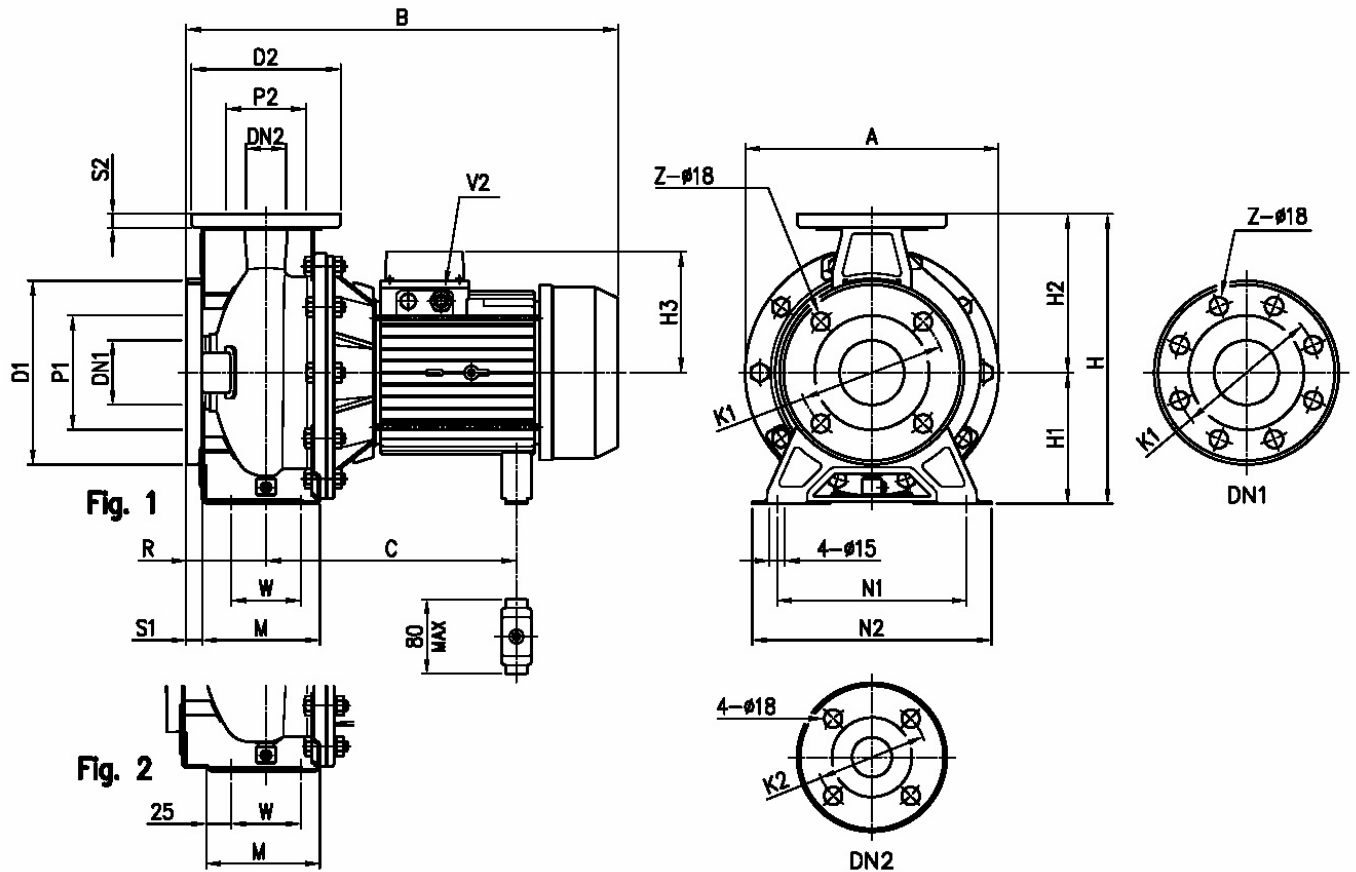

Dimensions in		mm						
1	A	296	H3	124				
2	B	452	M	115				
3	C	499	N1	212				
4	Dia D1	185	N2	265				
5	Dia D2	150	R	100				
6	Dia DN1	65	S1	16				
7	Dia DN2	40	S2	14				
8	Dia K1	145	V2	PG 13,5				
9	Dia K2	110	W	70				
10	Dia P1	115	Weight P&M	28,6 kg				
11	Dia P2	80	Z	4				
12	Fig	2						
13	H	340						
14	H1	160						
15	H2	180						

(1/3)

Construction

Pump Name 3M4 40-200/1.1

Customer	Date 2024-06-12	Company
Contact	Item no.	Issued by
Phone	Project	Phone
E-mail	Project ID Proiect redenumit 2024-06-12 12:10:37	E-mail

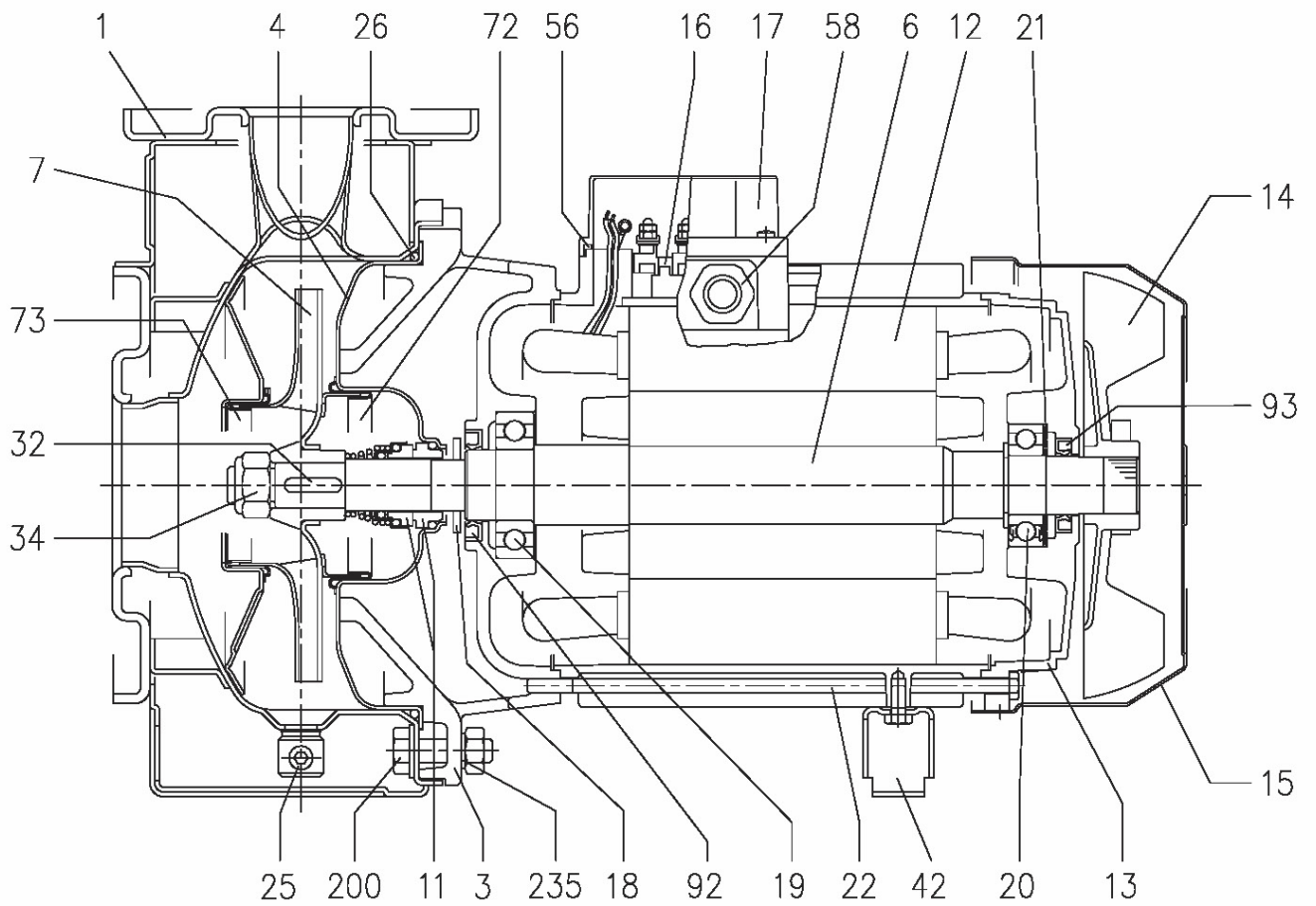

(2/3)

Construction

Pump Name 3M4 40-200/1.1

Customer	Date	2024-06-12	Company
Contact	Item no.		Issued by
Phone	Project		Phone
E-mail	Project ID	Project redenumit 2024-06-12 12:10:37	E-mail

N°	PART NAME	MATERIAL		DIMENSIONS	STANDARD	Q.TY	
		3M4	3LM4				
1	Casing	EN 1.4301 (AISI 304)	EN 1.4404 (AISI 316L)			1	
3	Motor bracket	[5]				1	
4	Casing cover	EN 1.4301 (AISI 304)	EN 1.4404 (AISI 316L)			1	
6	Shaft with rotor-Part in contact with liquid	EN 1.4301 (AISI 304)	EN 1.4404 (AISI 316L)			1	
7	Impeller	32, 40, 50	EN 1.4301 (AISI 304)	EN 1.4404 (AISI 316L)		1	
		65-125/160/200	EN 1.4401 (AISI 316)				
11	Mechanical seal	[3]	Carbon/Ceramic/NBR	SiC/SiC/FPM		1	
12	Motor frame with stator					1	
13	Motor cover	Aluminium				1	
14	Fan	PA				1	
15	Fan cover	Fe P04 Galvanized				1	
16	Terminal					1	
17	Terminal box cover	Aluminium (three phase version)				1	
18	Splash ring	NBR	/	40x21.5x3	EBARA DRAWING	1	
19	Bearing					1	
20	Bearing					1	
21	Adjusting ring	Steel C70				1	
22	Tie rod	Fe 42 Galvanized		M5	EBARA DRAWING	4	
25	Draing plug	EN 1.4401 (AISI 316) / PTFE		R 1/8" L=8	DIN 906	1	
26	O ring	32-125, 40-125	NBR [4]	FPM	158.11x5.34	OR 6625	1
		32-160, 40-160, 50-125, 65-160			183.52x5.34	OR 6720	
		32-200, 40-200,50-160, 50-200, 65-160, 65-200			227.96x5.34	OR 6895	
32	Key	EN 1.4401 (AISI 316)		6x6x25	UNI 6604	1	
34	Impeller nut	Other models	EN 1.4301 (AISI 304)	EN 1.4404 (AISI 316L)	M16x1.5	UNI 7474	1
		50-200/2.2			M18x1.5		
42	Foot	Aluminium / Galvanized steel			EBARA DRAWING	1	
56	Box gasket	NBR				1	
58	Fasting nut					1	
72	Casing ring (not for 65 version) [1]	EN 1.4301 (AISI 304)	EN 1.4404 (AISI 316L)			1	
73	Casing ring (not for 65 version)	EN 1.4301 (AISI 304)	EN 1.4404 (AISI 316L)			1	
92	O ring	Up to 1.5kW			25x40x7	DIN 3760 without spring	1
		From 2.2kW to 3kW			30x47X7		
93	O ring	For 0.25kW			15x30x5	DIN 3760 without spring	1
		For 0.37kW and 0.55kW			17x32X7		
		From 0.75 kW to 3kW			25x40x7		
200	Screw	32-125, 40-125	Stainless steel A2 70 class ISO 3506/1		M 8x30	UNI 5739	8
		40-160, 40-200, 50-125, 50-160, 50-200, 65-125, 65-160, 65-200			M 10x35		[2]
235	Washer	32-125, 40-125	EN 1.4301 (AISI 304)		8.4x17	UNI 6592	8
		40-160, 40-200, 50-125, 50-160, 50-200, 65-125, 65-160, 65-200			10.5x21		[2]

[1] For version 32-200, 40-200, 50-160 , 50-200

[2] Quantity = 10 for 32-160, 40-160, 50-125, 65-125
Quantity = 12 for 32-200, 40-200, 50-160, 50-200, 65-160, 65-200

[3] Special version: see CONSTRUCTION 3

[4] FPM for H-HS-HW-HSW version

EPDM for E version, Q1AEGG, U3U3EGG, Q1Q1EGG, Q1U3EGG, U3CEGG

[5] Cast iron EN-GJL-200-EN 1561 for 32-200/3 and models with 15, 18.5, 22 kW motor
Aluminum AL-EN-1706-AC-46000-D for all the others

(3/3)

Construction

Pump Name 3M4 40-200/1.1

Customer	Date 2024-06-12	Company
Contact	Item no.	Issued by
Phone	Project	Phone
E-mail	Project ID Proiect redenumit 2024-06-12 12:10:37	E-mail

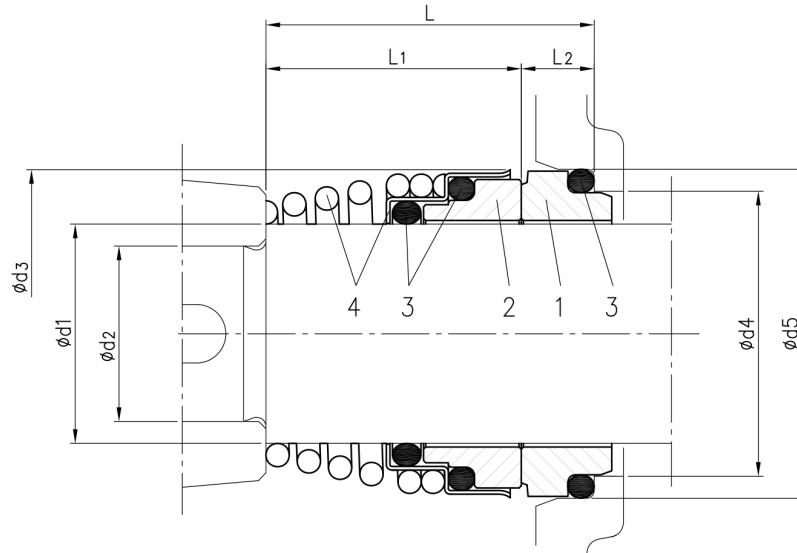

Version	Pump type	Dimensions							Material				
		d1	d2	d3	d4	d5	L	L1	L2	1 Stationary seal ring	2 Rotary seal ring	3 Rubber	4 Frame + spring
Standard	32-125/160/200 40-125/160/200 50-125/160/200 65-125/160/200	22	19	38	31	37	37.5	27.5	10	Carbon	Ceramic	NBR	EN 1.4401 (AISI 316)