

Technical Data

Pump Name

3M 32-160/2.2M

Customer	Date	2024-06-12	Company
Contact	Item no.		Issued by
Phone	Project		Phone
E-mail	Project ID	Proiect redenumit 2024-06-12 12:10:37	E-mail

Requested data

1	Pump type	CENTRIFUGAL PUMPS	Fluid	Water	
2	Number of pumps / Reserve	1 / 0	Liquid temperature	°C	20
3	Flow	m³/h	Kin. viscosity	mm²/s	1.005
4	Head	m	Vapour pressure	bar	0.0234
5	Geodetic head	m	PH value		
6	Inlet pressure (pin)	bar	Density	kg/m³	998.3
7	Available system NPSH		Solids	Weight %	0
8	Ambient temperature	°C	20		

Pump

9	Pump Name	3M 32-160/2.2M	Frequency	Hz	50		
10	Design	CENTRIFUGAL PUMPS	Installation type		STANDARD		
11	Manufacturer	EBARA	Impeller Diameter	Max.	mm	166	
12	Speed	rpm		2900	Designed	mm	166
13	No. of Stage	1		Min.	mm	166	
14	Connection	Suction side	DIN 2532	Flow	Operating	m³/h	
15	Connection	Discharge side	DIN 2532		Max-	m³/h	20
16	Max Working Pressure	bar	10		Min-	m³/h	6
17	Shut-off head	bar	3.62	Head	Operating	m	
18	Total weight	kg	See the table of "Dimensions".		- (Qmax.)	m	25.0
19	Shaft power	kW			- (Qmin.)	m	35.5
20				Max. Shaft Power at max. impeller	kW	2.18	
21	Required pump NPSH	m		Efficiency	%		

Materials

22	Impeller	AISI 304		
23	Casing	AISI 304		
24	Shaft	AISI 304		
25				
26				
27				

Motor

28	Manufacturer	EPE Standard	Insulation class	F		
29	Type	TEFC_3M32-160/2.2_230_Three Phase	Phases	3~		
30	Specific design	IE3 / 50 Hz / Pole pairs 1	Frame size			
31	Rated power	kW	2.2	Weight	kg	
32	Number of poles	2	Electric voltage	V	230	
33	Speed	rpm	2900	Electric current	A	8.2
34	Degree of protection	IP 55				
35						

Remarks

--

Performance Curve

Pump Name

3M 32-160/2.2M

Customer	Date	2024-06-12	Company
Contact	Item no.		Issued by
Phone	Project		Phone
E-mail	Project ID	Project redenumit 2024-06-12 12:10:37	E-mail

Requested data

1	Flow	m³/h	
2	Head	m	
3	Geodetic head	m	

Pump

Operating flow	m³/h		Frequency	Hz	50
Operating head	m		Number of poles		2
Impeller diameter designed	mm	166	Speed	rpm	2900

Test standard: ISO 9906:2012 - Grade3B

Water; 20°C; 998.3kg/m³; 1mm²/s

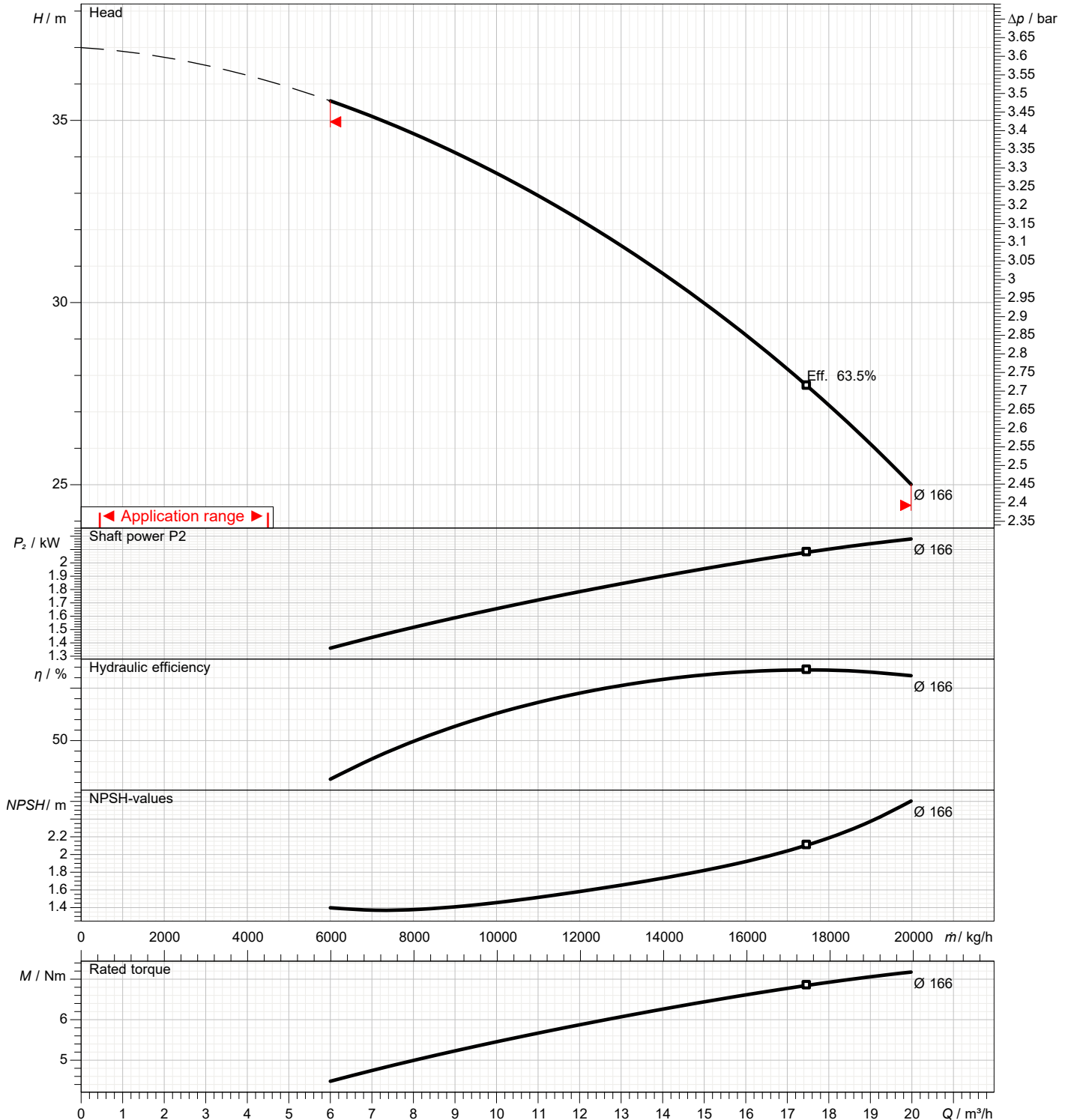

Dimensions

Pump Name 3M 32-160/2.2M

Customer	Date 2024-06-12	Company
Contact	Item no.	Issued by
Phone	Project	Phone
E-mail	Project ID Proiect redenumit 2024-06-12 12:10:37	E-mail

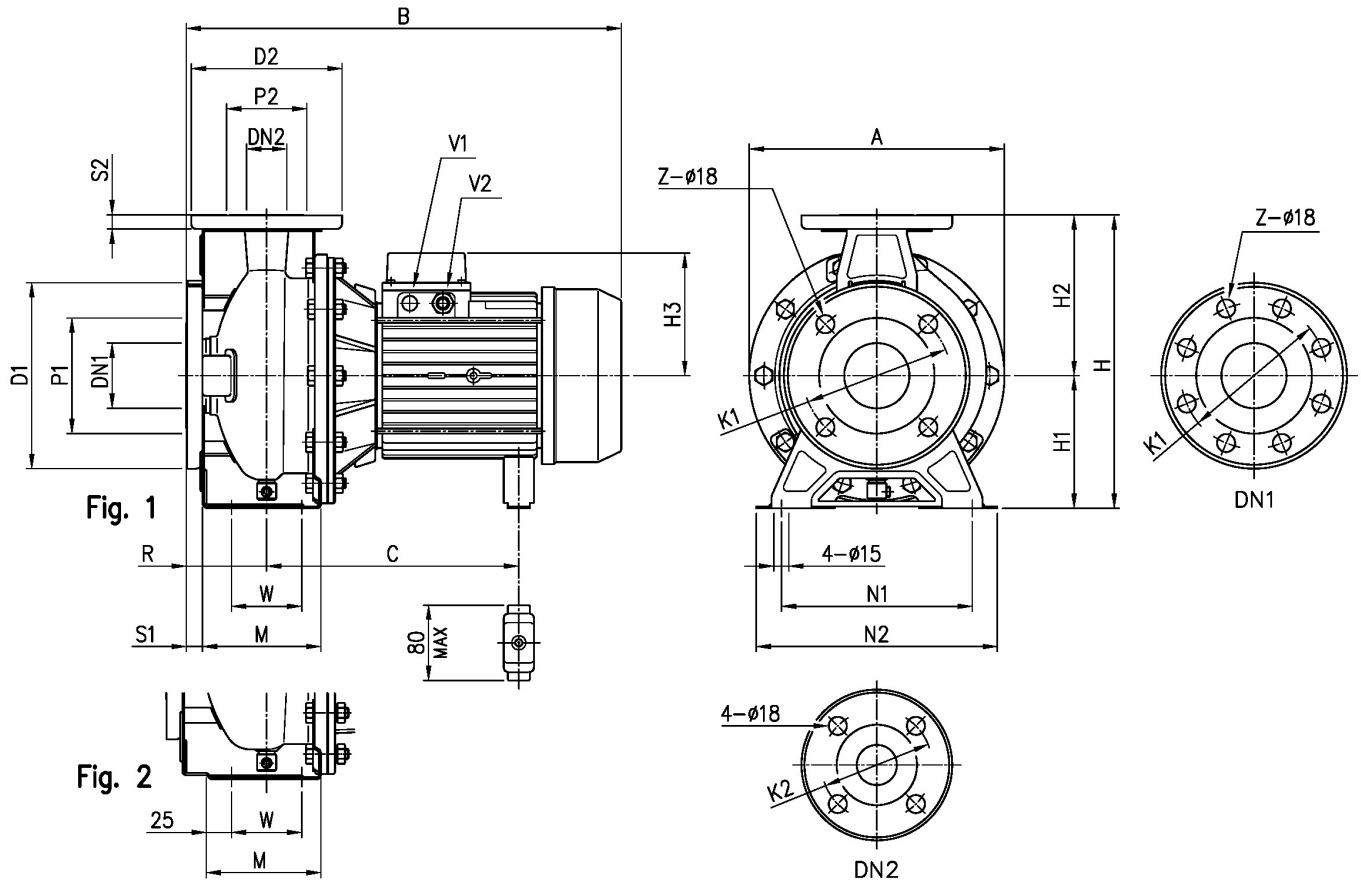

Dimensions in		mm						
1	A	254	H3	141				
2	B	446	M	118				
3	C	219or230	N1	190				
4	Dia D1	165	N2	240				
5	Dia D2	140	R	80				
6	Dia DN1	50	S1	16				
7	Dia DN2	32	S2	14				
8	Dia K1	125	V2	M20x1.5				
9	Dia K2	100	W	70				
10	Dia P1	95	Weight P&M	27 kg				
11	Dia P2	75	Z	4				
12	Fig	1						
13	H	292						
14	H1	132						
15	H2	160						

(1/3)

Construction

Pump Name 3M 32-160/2.2M

Customer	Date 2024-06-12	Company
Contact	Item no.	Issued by
Phone	Project	Phone
E-mail	Project ID Proiect redenumit 2024-06-12 12:10:37	E-mail

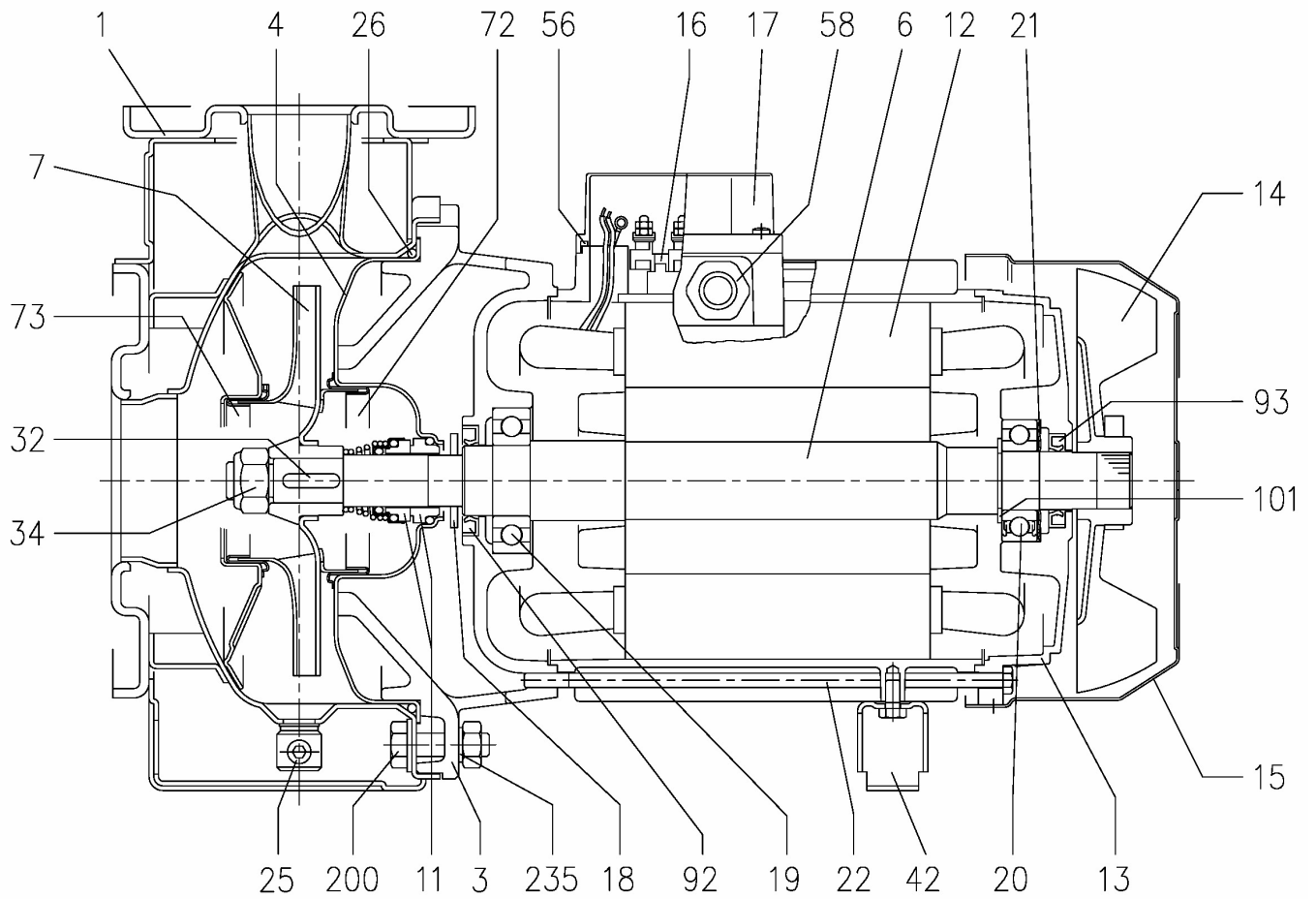

Customer	Date 2024-06-12	Company
Contact	Item no.	Issued by
Phone	Project	Phone
E-mail	Project ID Proiect redenumit 2024-06-12 12:10:37	E-mail

N°	PART NAME	MATERIAL		DIMENSIONS	STANDARD	Q.TY	
		3M	3LM				
1	Casing	EN 1.4301 (AISI 304)	EN 1.4404 (AISI 316L)			1	
3	Motor bracket		[9]			1	
4	Casing cover	EN 1.4301 (AISI 304)	EN 1.4404 (AISI 316L)			1	
6	Shaft with rotor-Part in contact with liquid	EN 1.4301 (AISI 304)	EN 1.4404 (AISI 316L)			1	
7	Impeller	EN 1.4301 (AISI 304)	EN 1.4404 (AISI 316L)			1	
11	Mechanical seal	Carbon/Ceramic/NBR	SiC/SiC/FPM	[8]		1	
12	Motor frame with stator	-				1	
13	Motor cover	Aluminium				1	
14	Fan	PA				1	
15	Fan cover	Fe P04 Galvanized				1	
16	Terminal	-				1	
17	Terminal box cover	Aluminium (three phase version)				1	
18	Splash ring	Up to 11 kW 15 kW and above	NBR /	40x21.5x3 50x29.5x3	EBARA DRAWING	1	
19	Bearing	-		See table p.324		1	
20	Bearing	-		See table p.324		1	
21	Adjusting ring	Steel C70				1	
22	Tie rod	Up to 3 kW	Fe 42 Galvanized	M5	EBARA DRAWING	4	
		For 4 - 5.5 - 7.5 kW		M6			
		9.2 e 11kW		M8			
	Screw	15 kW and above	Galvanized Steel 8.8 strenght class ISO 898-1	M10x40	UNI 5739		
25	Draing plug	EN 1.4401 (AISI 316) / PTFE		R 1/8" L=8	DIN 906	1	
26	"O" ring	32-125, 40-125	NBR [7]	FPM	158.11x5.34	OR 6625	1
		32-160, 40-160, 50-125			183.52x5.34	OR 6720	
		32-200, 40-200, 50-160, 50-200, 65-160, 65-200			227.96x5.34	OR 6895	
32	Key	Up to 11 kW 15 kW and above	EN 1.4401 (AISI 316)		A 6x6x25 A 8x7x30	UNI 6604	1
34	Impeller nut	Up to 11kW	EN 1.4301 (AISI 304)	EN 1.4404 (AISI 316L)	M16x1.5	UNI 7474	1
		50-200/15			M18x1.5		
		15 kW and above			M20x1.5		
42	Foot	Aluminium / Galvanized steel			EBARA DRAWING	[1]	
56	Box gasket	NBR				1	
58	Fasting nut	-				[2]	
72	Casing ring [3]	EN 1.4301 (AISI 304)	EN 1.4404 (AISI 316L)			1	
73	Casing ring	EN 1.4301 (AISI 304)	EN 1.4404 (AISI 316L)			1	
92	Lip seal	Up to 3kW	-	-	25x40x7	DIN 3760 without spring	1
		From 4 to 7.5 kW			30x47X7		
		From 9.2 kW to 11 kW			40x55x7		
		From 15 kW to 22 kW			45x60x7		
093	Lip seal	Up to 4 kW	-	-	25x40x7	DIN 3760 without spring	1
		From 5.5 kW to 7.5 kW			30x47X7		
		From 9.2 kW to 11 kW			40x55x7		
		From 15 kW to 22 kW			45x60x7		
101	Snap ring (only 9.2 and 11kW)	Carbon tool steels TC 80		Ø 40	UNI 7435	1	
200	Screw	32-125, 40-125	Stainless steel A2 70 class ISO 3506/1	M 8x30	UNI 5739	8	
		40-160, 40-200, 50-125, 50-160, 50-200, 65-125, 65-160, 65-200		M 10x35			
235	Washer	32-125, 40-125	EN 1.4301 (AISI 304)	8.4x17	UNI 6592	8	
		40-160, 40-200, 50-125, 50-160, 50-200, 65-125, 65-160, 65-201		10.5x21			
206	Screw for bracket [5]	Galvanized Steel 8.8 strenght class ISO 898-1		M 10x40	UNI 5739	4	
244	Pin [6]	-	EN 1.4301 (AISI 304)	4x15		1	

[1] Quantity =0 for 65-160/15

Quantity =1 for 32-40-50 and 65 up to 11kW

Quantity =2 for 65-200/15, 65-200/18.5, 65-200/22

[2] Quantity =1 up to 11kW

Quantity =2 from 15kW to 22kW

[3] For version 32-200/3, 32-200/4, 32-200/5.5, 40-200/5.5, 40-200/7.5, 40-200/11, 50-160/5.5, 50-160/7.5, 50-200/9.2, 50-200/11, 50-200/15

[4] Quantity =10 for 32-160, 40-160, 50-125, 65-125

Quantity =12 for 32-200, 40-200, 50-160, 50-200, 65-160, 65-200

[5] For 15kW and above

[6] Only for 65-160/15 and 65-200

[7] FPM for H-HS-HW-HSW version

EPDM for E version, Q1AEGG, Q1Q1EGG, Q1U3EGG, U3CEGG, U3U3EGG (U3U3EGG not available for model 65-160/15 and 65-200)

[8] Special version: see CONSTRUCTION 3

[9] Cast iron EN-GJL-200-EN 1561 for 32-200/3 and models with 15, 18.5, 22 kW motor
Aluminium AL-EN-1706-AC-46000-D for all the others.

(3/3)

Construction

Pump Name 3M 32-160/2.2M

Customer	Date 2024-06-12	Company
Contact	Item no.	Issued by
Phone	Project	Phone
E-mail	Project ID Proiect redenumit 2024-06-12 12:10:37	E-mail

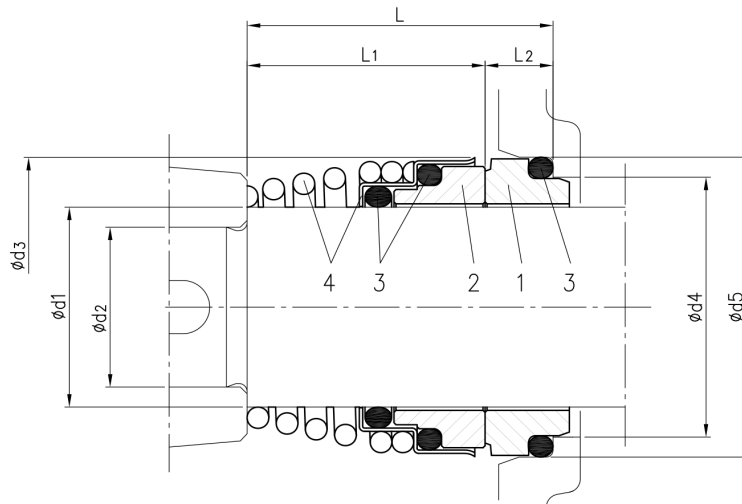

Version	Pump type	Dimensions								Material			
		d1	d2	d3	d4	d5	L	L1	L2	1 Stationary seal ring	2 Rotary seal ring	3 Rubber	4 Frame + Spring
Standard	32-125/160/200	22	19	38	31	37	37.5	27.5	10	Carbon	Ceramic	NBR	EN 1.4401 (AISI 316)
	40-125/160/200												
	50-125/160/200												
	65-125												
	65-160/7.5-9.2-11												
	65-160/15												
65-200													