

Technical Data

Pump Name

3PF4 65-160L

Customer	Date	2024-06-12	Company
Contact	Item no.		Issued by
Phone	Project		Phone
E-mail	Project ID	Proiect redenumit 2024-06-12 12:10:37	E-mail

Requested data

1	Pump type	CENTRIFUGAL PUMPS	Fluid	Water
2	Number of pumps / Reserve	1 / 0	Liquid temperature	°C
3	Flow	m³/h	Kin. viscosity	mm²/s
4	Head	m	Vapour pressure	bar
5	Geodetic head	m	PH value	
6	Inlet pressure (pin)	bar	Density	kg/m³
7	Available system NPSH		Solids	Weight %
8	Ambient temperature	°C		

Pump

9	Pump Name	3PF4 65-160L	Frequency	Hz	50	
10	Design	CENTRIFUGAL PUMPS	Installation type		STANDARD	
11	Manufacturer	EBARA	Impeller Diameter	Max.	mm	
12	Speed	rpm		1400	Designed	mm
13	No. of Stage			1	Min.	mm
14	Connection	Suction side	DIN 2532	Flow	Operating	
15	Connection	Discharge side	DIN 2532		Max-	m³/h
16	Max Working Pressure	bar	10		Min-	m³/h
17	Shut-off head	bar	1.15	Head	Operating	
18	Total weight	kg	See the table of "Dimensions".		- (Qmax.)	m
19	Shaft power	kW			- (Qmin.)	m
20				Max. Shaft Power at max. impeller	kW	
21	Required pump NPSH	m		Efficiency	%	

Materials

22	Impeller	AISI 316		
23	Casing	AISI 304		
24	Shaft	AISI 304		
25				
26				
27				

Motor

28	Manufacturer	without motor	Insulation class	
29	Type	without motor 3	Phases	
30	Specific design	without motor / 50 Hz / Pole pairs 2	Frame size	
31	Rated power	kW	Weight	kg
32	Number of poles	4	Electric voltage	V
33	Speed	rpm	Electric current	A
34	Degree of protection			
35				

Remarks

Performance Curve

Pump Name

3PF4 65-160L

Customer	Date	2024-06-12	Company
Contact	Item no.		Issued by
Phone	Project		Phone
E-mail	Project ID	Proiect redenumit 2024-06-12 12:10:37	E-mail

Requested data

1	Flow	m³/h	
2	Head	m	
3	Geodetic head	m	

Pump

Operating flow	m³/h		Frequency	Hz	50
Operating head	m		Number of poles		4
Impeller diameter designed	mm	178	Speed	rpm	1400

Test standard: ISO 9906:2012 - Grade3B

Water; 20°C; 998.3kg/m³; 1mm²/s

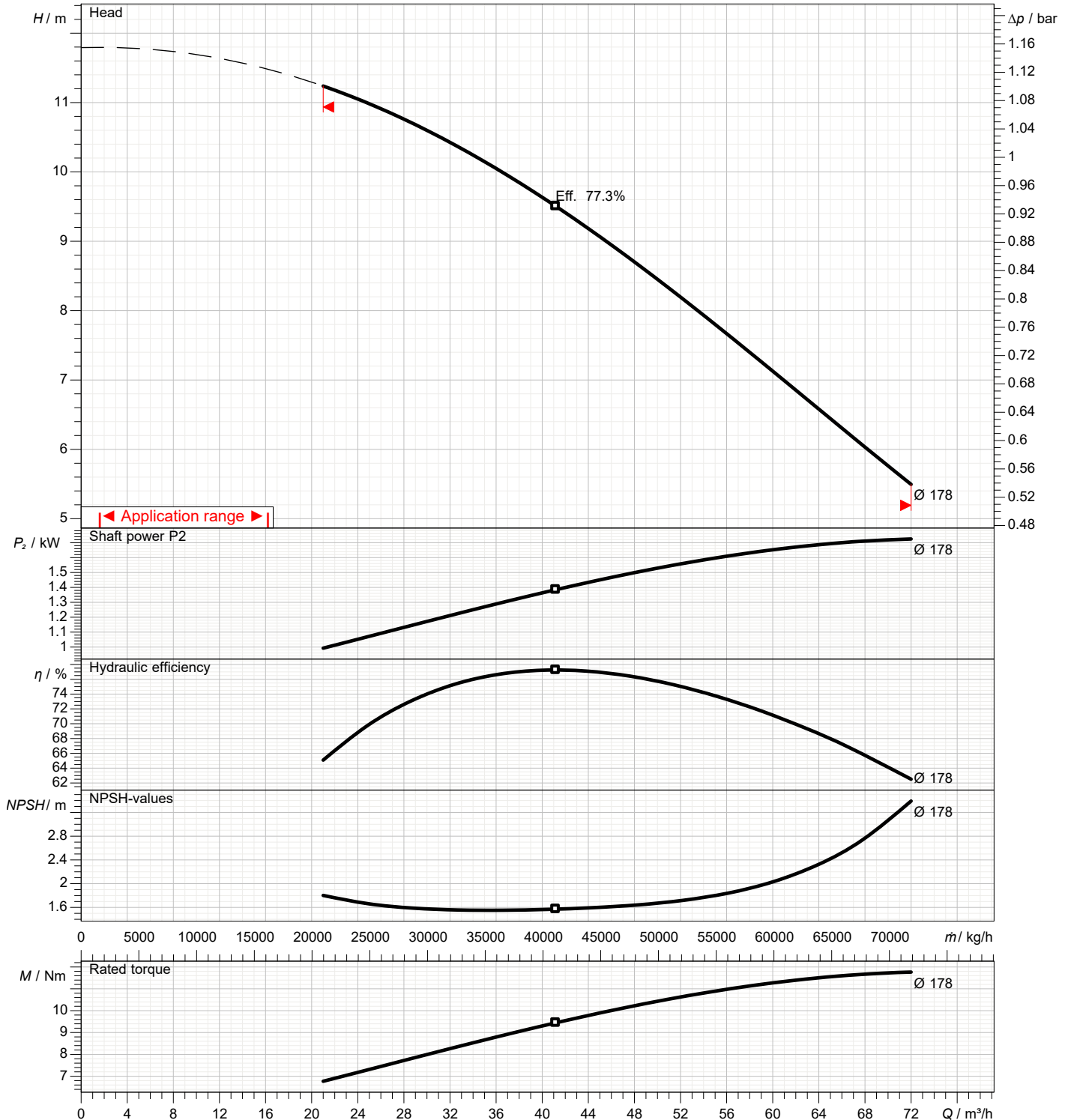

Dimensions

Pump Name 3PF4 65-160L

Customer	Date 2024-06-12	Company
Contact	Item no.	Issued by
Phone	Project	Phone
E-mail	Project ID Proiect redenumit 2024-06-12 12:10:37	E-mail

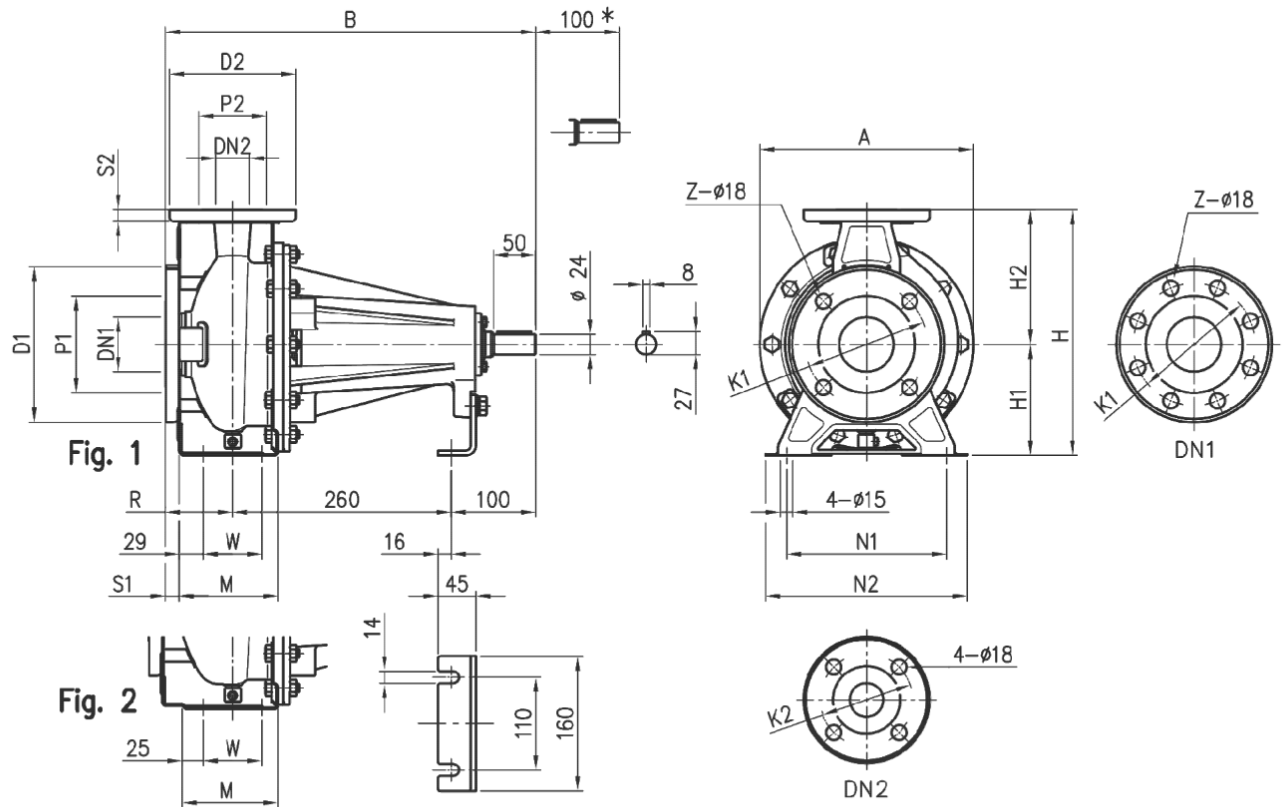

* Space for disassembly

Dimensions in		mm		
1	A	296	N1	212
2	B	460	N2	280
3	Dia D1	200	R	100
4	Dia D2	185	S1	18
5	Dia DN1	80	S2	16
6	Dia DN2	65	W	95
7	Dia K1	160	Weight PUMP	29 kg
8	Dia K2	145	Z	8
9	Dia P1	134	Z option	4
10	Dia P2	115		
11	Fig	2		
12	H	360		
13	H1	160		
14	H2	200		
15	M	140		

(1/3)

Construction

Pump Name 3PF4 65-160L

Customer	Date 2024-06-12	Company
Contact	Item no.	Issued by
Phone	Project	Phone
E-mail	Project ID Proiect redenumit 2024-06-12 12:10:37	E-mail

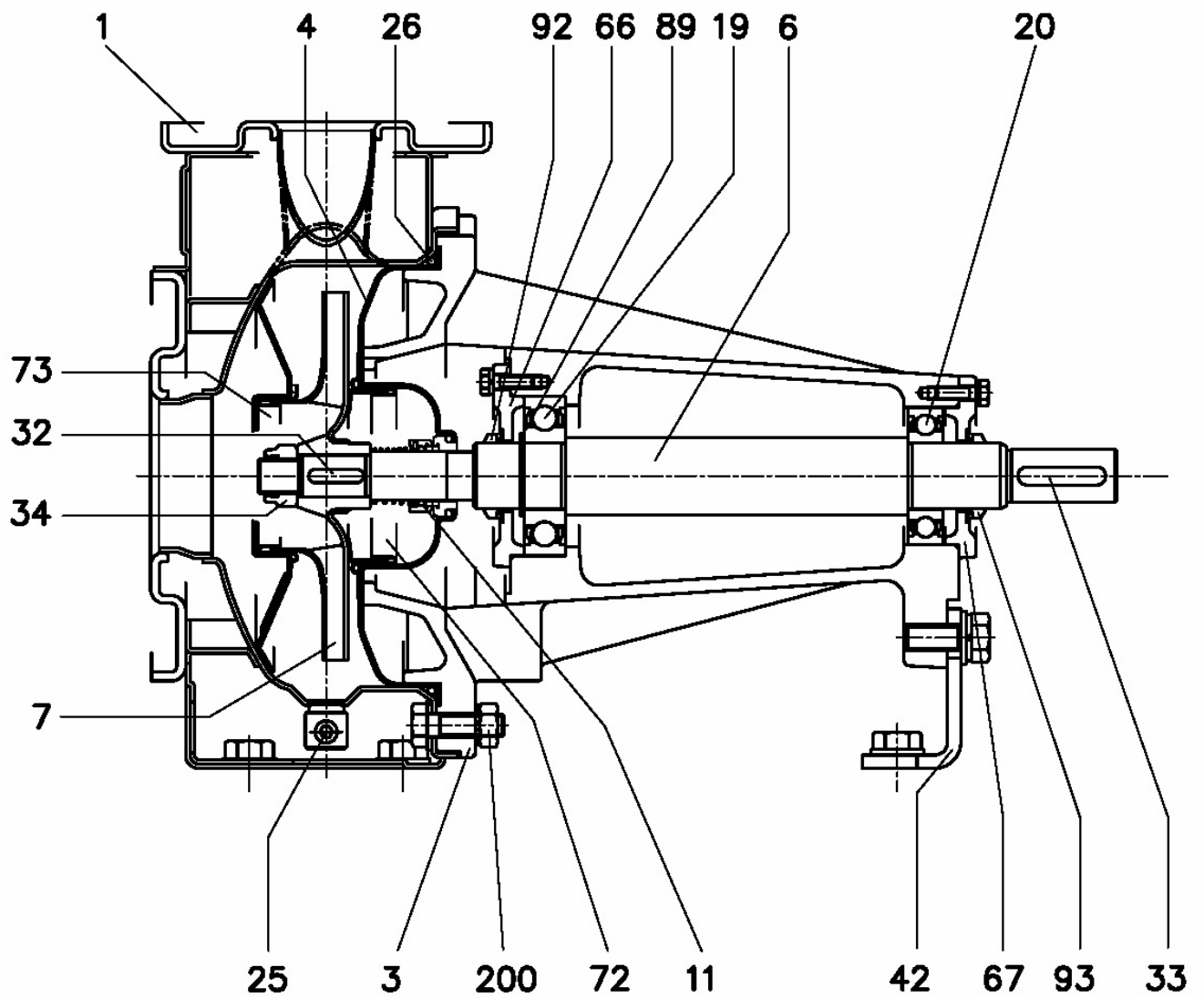

(2/3)

Construction

Pump Name 3PF4 65-160L

Customer	Date	2024-06-12	Company
Contact	Item no.		Issued by
Phone	Project		Phone
E-mail	Project ID	Project redenumit 2024-06-12 12:10:37	E-mail

N°	PART NAME	MATERIAL		DIMENSIONS	STANDARD	Q.TY	
		3PF(4)	3LPF(4)				
1	Casing	EN 1.4301 (AISI 304)	EN 1.4404 (AISI 316L)			1	
3	Support	Cast iron EN-GJL-200-EN 1561				1	
4	Casing cover	EN 1.4301 (AISI 304)	EN 1.4404 (AISI 316L)			1	
6	Shaft - Part in contact with liquid	EN 1.4301 (AISI 304)	EN 1.4404 (AISI 316L)			1	
7	Impeller 32-40-50	EN 1.4301 (AISI 304)	EN 1.4404 (AISI 316L)			1	
	65-125/160/200	EN 1.4401 (AISI 316)					
11	Mechanical seal [3]	Carbon/Ceramic/NBR	SiC/SiC/FPM			1	
19	Bearing	-				1	
20	Bearing	-				1	
25	Draining plug	EN 1.4401 (AISI 316) / PTFE		R 1/8" L=8	DIN 906	1	
26	O ring	32-125, 40-125	NBR [4]	FPM	158.11x5.34	OR 6625	1
		32-160, 40-160, 50-125, 65-125			183.52x5.34	OR 6720	
		32-200, 40-200, 50-160, 50-200, 65-160, 65-200			227.96x5.34	OR 6895	
32	Key	EN 1.4401 (AISI 316)		6x6x25	UNI 6604	1	
33	Key	C 40		8x7x40	UNI 6604	1	
34	Impeller nut	Other model	EN 1.4301 (AISI 304)	EN 1.4404 (AISI 316L)	M16x1.5	UNI 7474	1
		50-200/2.2			M18x1.5		
42	Pump support	Zinc-coated steel			EBARA DRAWING	1	
66	Impeller side bearing cover	Cast iron EN-GJL-200-EN 1561				1	
67	Motor side bearing cover	Cast iron EN-GJL-200-EN 1561				1	
72	Casing ring (not for 65 version) [1]	EN 1.4301 (AISI 304)	EN 1.4404 (AISI 316L)			1	
73	Casing ring (not for 65 version)	EN 1.4301 (AISI 304)	EN 1.4404 (AISI 316L)			1	
89	Snap ring	32-125, 32-160, 40-125, 50-125	Carbon tool steel TC 80		Ø30	UNI 7435	1
		Other model			Ø40		
92	O ring	-		VS - 0030		1	
93	O ring	-		VS - 0030		1	
200	Screw	32-125, 40-125	Stainless steel A2 70 class ISO 3506/1		M 8x30	UNI 5739	8
		40-160, 40-200, 50-125, 50-160, 50-200, 65-125, 65-160, 65-200			M 10x35	UNI 5739	

[1] For version: 32-200, 40-200, 50-160, 50-200

[2] N° for 1 unit=10 for 32-160, 40-160, 50-125, 65-125

N° for 1 unit=12 for 32-200, 40-200, 50-160, 50-200, 65-160, 65-200

[3] Special version: see CONSTRUCTION 3

[4] FPM for H-HS-HW-HSW option

EPDM for E version, Q1AEGG, U3U3EGG, Q1Q1EGG, Q1U3EGG, U3CEGG

(3/3) Construction

Pump Name 3PF4 65-160L

Customer	Date 2024-06-12	Company
Contact	Item no.	Issued by
Phone	Project	Phone
E-mail	Project ID Proiect redenumit 2024-06-12 12:10:37	E-mail

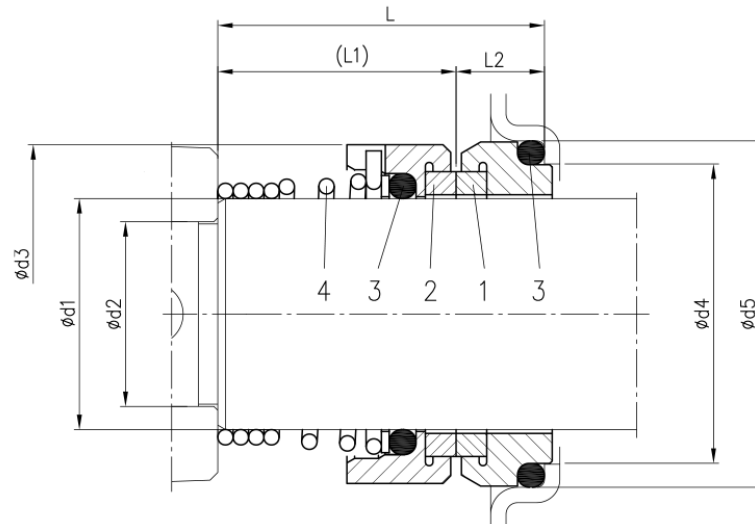

Version	Pump type	Dimensions								Material			
		d1	d2	d3	d4	d5	L	L1	L2	1 Stationary seal ring	2 Rotary seal ring	3 Rubber	4 Frame + spring
Standard	32-125/160/200 40-125/160/200 50-125/160/200 65-125/160/200	22	19	38	31	37	37.5	27.5	10	Carbon	Ceramic	NBR	EN 1.4401 (AISI 316)