

# Technical Data

Pump Name

3PF 50-125/S

Customer	Date	2024-06-12	Company
Contact	Item no.		Issued by
Phone	Project		Phone
E-mail	Project ID	Proiect redenumit 2024-06-12 12:10:37	E-mail

## Requested data

1	Pump type	CENTRIFUGAL PUMPS	Fluid	Water
2	Number of pumps / Reserve	1 / 0	Liquid temperature	°C
3	Flow	m³/h	Kin. viscosity	mm²/s
4	Head	m	Vapour pressure	bar
5	Geodetic head	m	PH value	
6	Inlet pressure (pin)	bar	Density	kg/m³
7	Available system NPSH		Solids	Weight %
8	Ambient temperature	°C		

## Pump

9	Pump Name	3PF 50-125/S	Frequency	Hz	50	
10	Design	CENTRIFUGAL PUMPS	Installation type		STANDARD	
11	Manufacturer	EBARA	Impeller Diameter	Max.	mm	
12	Speed	rpm		2900	Designed	mm
13	No. of Stage			1	Min.	mm
14	Connection	Suction side	DIN 2532	Flow	Operating	
15	Connection	Discharge side	DIN 2532		Max-	m³/h
16	Max Working Pressure	bar	10		Min-	m³/h
17	Shut-off head	bar	1.86	Head	Operating	
18	Total weight	kg	See the table of "Dimensions".		- (Qmax.)	m
19	Shaft power	kW			- (Qmin.)	m
20				Max. Shaft Power at max. impeller	kW	
21	Required pump NPSH	m		Efficiency	%	

## Materials

22	Impeller	AISI 304	
23	Casing	AISI 304	
24	Shaft	AISI 304	
25			
26			
27			

## Motor

28	Manufacturer	without motor	Insulation class
29	Type	without motor 3	Phases
30	Specific design	without motor / 50 Hz / Pole pairs 1	Frame size
31	Rated power	kW	Weight
32	Number of poles	2	Electric voltage
33	Speed	rpm	Electric current
34	Degree of protection		
35			

## Remarks

# Performance Curve

Pump Name

3PF 50-125/S

Customer	Date	2024-06-12	Company
Contact	Item no.		Issued by
Phone	Project		Phone
E-mail	Project ID	Proiect redenumit 2024-06-12 12:10:37	E-mail

**Requested data**

1	Flow	m³/h	
2	Head	m	
3	Geodetic head	m	

**Pump**

Operating flow	m³/h		Frequency	Hz	50
Operating head	m		Number of poles		2
Impeller diameter designed	mm	126	Speed	rpm	2900

Test standard: ISO 9906:2012 - Grade3B

Water; 20°C; 998.3kg/m³; 1mm²/s

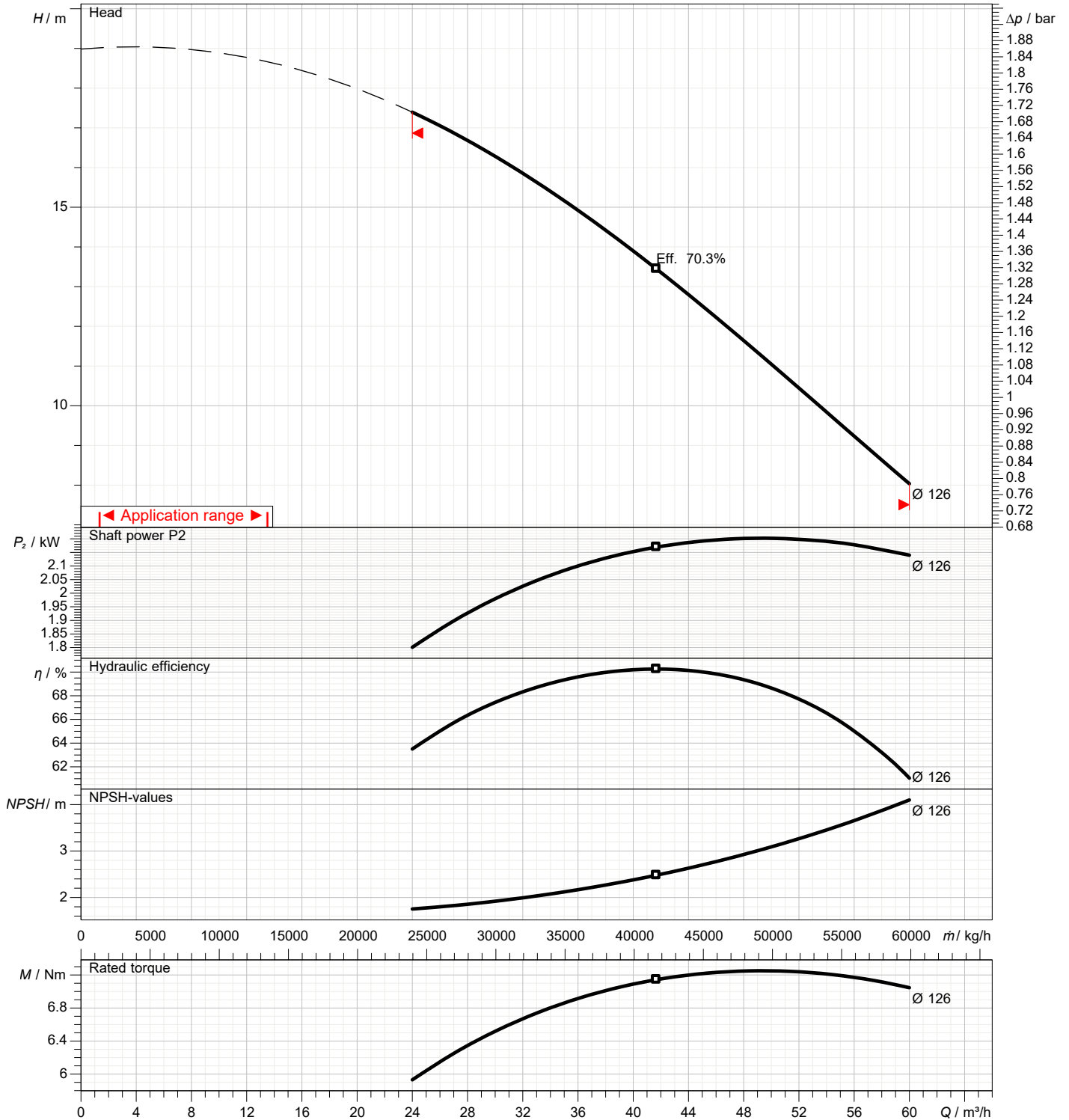

# Dimensions

Pump Name 3PF 50-125/S

Customer	Date 2024-06-12	Company
Contact	Item no.	Issued by
Phone	Project	Phone
E-mail	Project ID Proiect redenumit 2024-06-12 12:10:37	E-mail

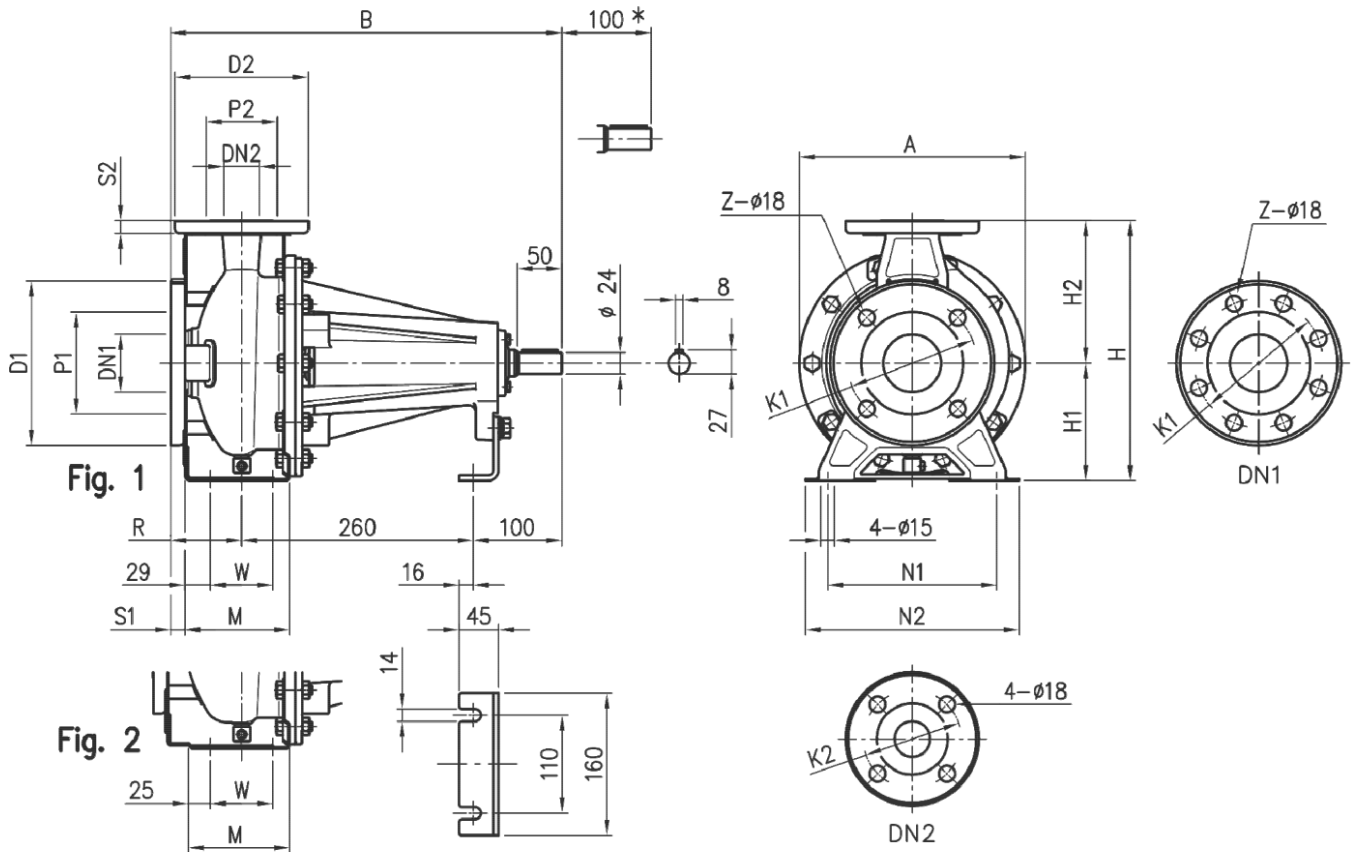

\* Space for disassembly

Dimensions in		mm		
1	A	254	N1	190
2	B	460	N2	240
3	Dia D1	185	R	100
4	Dia D2	165	S1	16
5	Dia DN1	65	S2	16
6	Dia DN2	50	W	70
7	Dia K1	145	Weight PUMP	19 kg
8	Dia K2	125	Z	4
9	Dia P1	115		
10	Dia P2	95		
11	Fig	2		
12	H	292		
13	H1	132		
14	H2	160		
15	M	114		

(1/3)

# Construction

Pump Name 3PF 50-125/S

Customer	Date 2024-06-12	Company
Contact	Item no.	Issued by
Phone	Project	Phone
E-mail	Project ID Proiect redenumit 2024-06-12 12:10:37	E-mail

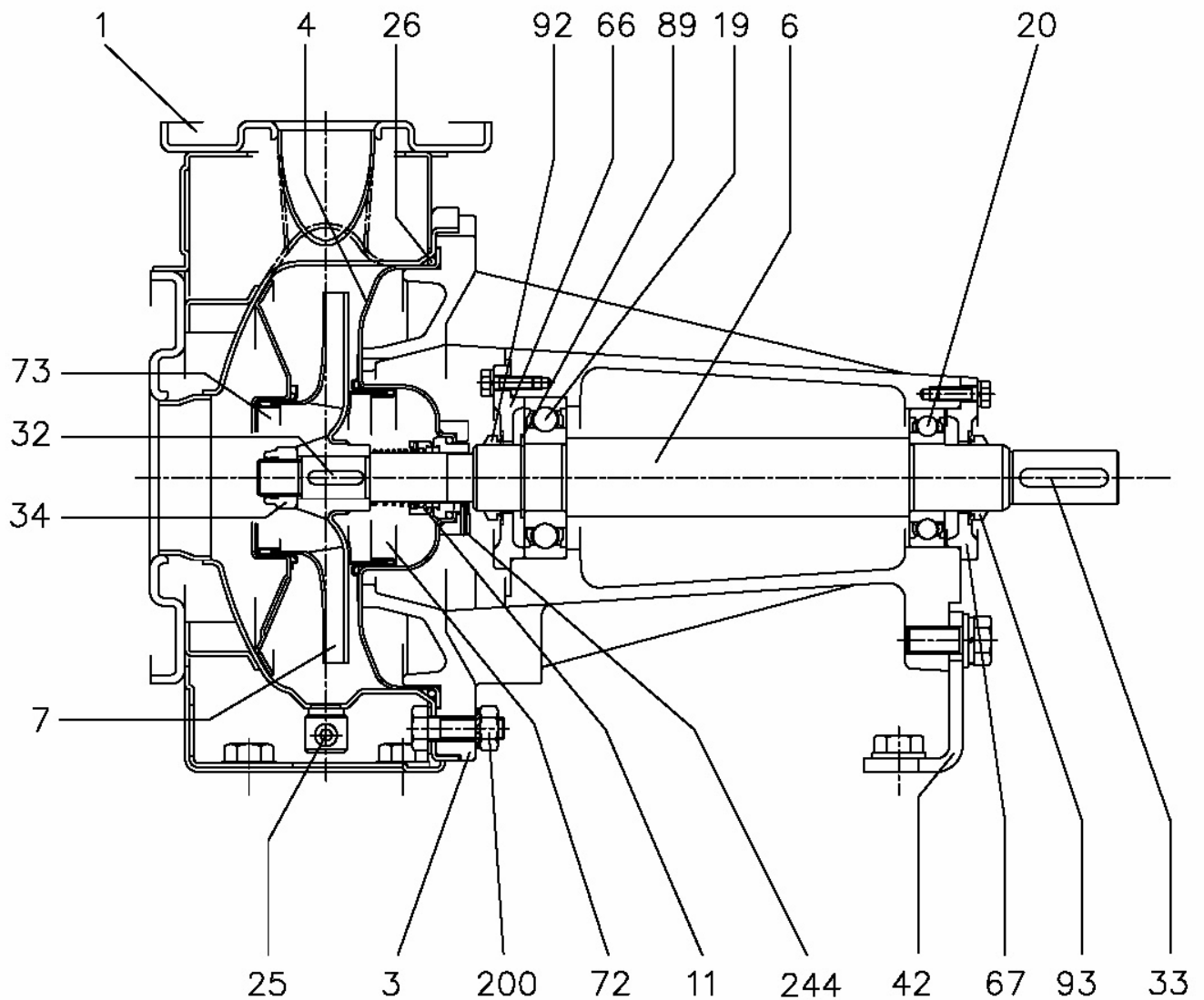

(2/3)

# Construction

Pump Name 3PF 50-125/S

Customer	Date	2024-06-12	Company
Contact	Item no.		Issued by
Phone	Project		Phone
E-mail	Project ID	Project redenumit 2024-06-12 12:10:37	E-mail

N°	PART NAME	MATERIAL		DIMENSIONS	STANDARD	Q.TY	
		3P	3LP				
1	Casing	EN 1.4301 (AISI 304)	EN 1.4404 (AISI 316L)			1	
3	Support	Cast iron EN-G JL-200-EN 1561				1	
4	Casing cover	EN 1.4301 (AISI 304)	EN 1.4404 (AISI 316L)			1	
6	Shaft - Part in contact with liquid	EN 1.4301 (AISI 304)	EN 1.4404 (AISI 316L)			1	
7	Impeller	32,40,50	EN 1.4301 (AISI 304)	EN 1.4404 (AISI 316L)		1	
		65-125/160/200	EN 1.440 1 (AISI 316)				
11	Mechanical seal [4]	Carbon/Ceramic/NBR	SIC/SIC/FPM			1	
19	Bearing	-	-			1	
20	Bearing	-	-			1	
25	Draing plug	EN 1.4401 (AISI 316) / PTFE		R 1/8" L=8	DIN 906	1	
26	O ring	32-125, 40-125	NBR [5]	FPM	158.11x5,34	OR 6625	1
		32-160, 40-160, 50-125, 65-125			183.52x5,34	OR 6720	
		32-200, 40-200, 50-160, 50-200, 65-160, 65-200			227.96x5,34	OR 6895	
32	Key	Up to 11 Kw 15 kW and above	EN 1.4301 (AISI 304)	EN 1.4401 (AISI 316)	6 x6x 25	UNI 6604	1
					8 x7x 30		
33	Key	C 40		8x7x40	UNI 6604	1	
34	Impeller nut	Up to 11kW 50-200/15 15 kW and above	EN 1.4301 (AISI 304)	EN 1.4404 (AISI 316L)	M16x1.5	UNI 7474	1
					M18x1.5		
					M20x1.5		
42	Pump support	Fe 37 ZI nc-coated			EBARA DRAWING	1	
66	Impeller side bearing cover	Cast iron EN-G JL-200-EN 1561				1	
67	Motor side bearing cover	Cast iron EN-G JL-200-EN 1561				1	
72	Casing ring [1]	EN 1.4301 (AISI 304)	EN 1.4404 (AISI 316L)			1	
73	Casing ring (not for 65 version)	EN 1.4301 (AISI 304)	EN 1.4404 (AISI 316L)			1	
89	Snap ring	Carbon tool steels TC 80		Ø 40	UNI 7435	1	
92	O ring	-	-	VS - 0030		1	
93	O ring	-	-	VS - 0030		1	
200	Screw	32-125, 40-125	Stainless steel A2 70 class ISO 3506/ 1	M 8x30	UNI 5739	8	
		40-160, 40-200, 50-125,					
		50-160, 50-200, 65-125,					
		65-160, 65-200					
244	Pin [3]	-	EN 1.4301 (AISI 304)	4x15		1	

[1] For version 32-200, 40-200, 50-160, 50-200

[2] Q.TY=10 for 32-160, 40-160, 50-125, 65-125

Q.TY=12 for 32-200, 40-200, 50-160, 50-200, 65-160, 65-200

[3] Only for 65-160/15 and 65-200

[4] Special version: see CONSTRUCTION 3

[5] FPM for H-HS-HW-HSW version

EPDM for E version, Q1AEGG, Q1U3EGG, U3CEGG, Q1Q1EGG, U3U3EGG

U3CU3EGG not available for models 65-160/15 and 65-200

# (3/3) Construction

Pump Name 3PF 50-125/S

Customer	Date 2024-06-12	Company
Contact	Item no.	Issued by
Phone	Project	Phone
E-mail	Project ID Proiect redenumit 2024-06-12 12:10:37	E-mail

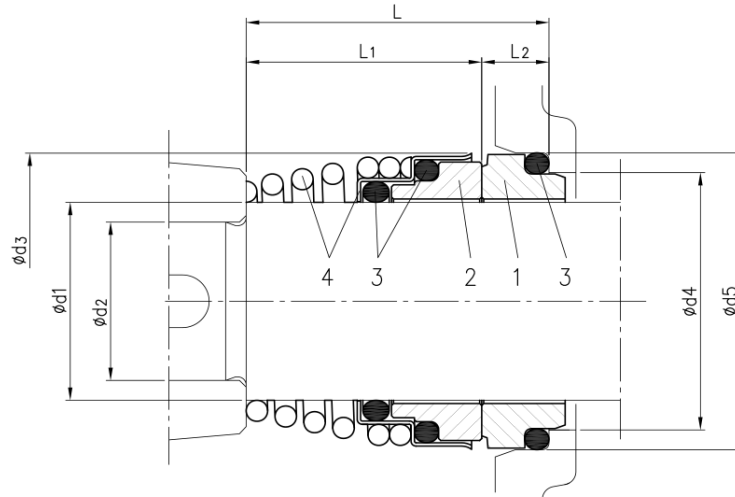

Version	Pump type	Dimensions								Material			
		d1	d2	d3	d4	d5	L	L1	L2	1 Stationary seal ring	2 Rotary seal ring	3 Rubber	4 Frame + spring
Standard	32-125/160/200												
	40-125/160/200												
	50-125/160/200	22	19	38	31	37	37.5	27.5	10	Carbon	Ceramic	NBR	EN 1.4401 (AISI 316)
	65-125												
	65-160/7.5-9.2-11												
65-160/15	30	24	46	39	45	42.5	32.5	10					
	65-200												