

# Technical Data

Pump Name

3P 32-160/1.5

Customer	Date	2024-06-12	Company
Contact	Item no.		Issued by
Phone	Project		Phone
E-mail	Project ID	Proiect redenumit 2024-06-12 12:10:37	E-mail

## Requested data

1	Pump type	CENTRIFUGAL PUMPS	Fluid	Water
2	Number of pumps / Reserve	1 / 0	Liquid temperature	°C
3	Flow	m³/h	Kin. viscosity	mm²/s
4	Head	m	Vapour pressure	bar
5	Geodetic head	m	PH value	
6	Inlet pressure (pin)	bar	Density	kg/m³
7	Available system NPSH		Solids	Weight %
8	Ambient temperature	°C		

## Pump

9	Pump Name	3P 32-160/1.5	Frequency	Hz	50	
10	Design	CENTRIFUGAL PUMPS	Installation type		STANDARD	
11	Manufacturer	EBARA	Impeller Diameter	Max.	mm	
12	Speed	rpm		2900	Designed	mm
13	No. of Stage			1	Min.	mm
14	Connection	Suction side	DIN 2532	Flow	Operating	
15	Connection	Discharge side	DIN 2532		Max-	m³/h
16	Max Working Pressure	bar	10		Min-	m³/h
17	Shut-off head	bar	2.89	Head	Operating	
18	Total weight	kg	See the table of "Dimensions".		- (Qmax.)	m
19	Shaft power	kW			- (Qmin.)	m
20				Max. Shaft Power at max. impeller	kW	
21	Required pump NPSH	m		Efficiency	%	

## Materials

22	Impeller	AISI 304		
23	Casing	AISI 304		
24	Shaft	AISI 304		
25				
26				
27				

## Motor

28	Manufacturer	LAFERT	Insulation class	F	
29	Type	TEFC_3P32-160/1.5_230_Three Phase	Phases	3~	
30	Specific design	IE3 / 50 Hz / Pole pairs 1	Frame size	90S	
31	Rated power	kW	1.5	Weight	kg
32	Number of poles		2	Electric voltage	V
33	Speed	rpm	2900	Electric current	A
34	Degree of protection				
35					

## Remarks

# Performance Curve

Pump Name

3P 32-160/1.5

Customer	Date	2024-06-12	Company
Contact	Item no.		Issued by
Phone	Project		Phone
E-mail	Project ID	Project redenumit 2024-06-12 12:10:37	E-mail

### Requested data

1	Flow	m³/h	
2	Head	m	
3	Geodetic head	m	

### Pump

Operating flow	m³/h		Frequency	Hz	50
Operating head	m		Number of poles		2
Impeller diameter designed	mm	151	Speed	rpm	2900

Test standard: ISO 9906:2012 - Grade3B

Water; 20°C; 998.3kg/m³; 1mm²/s

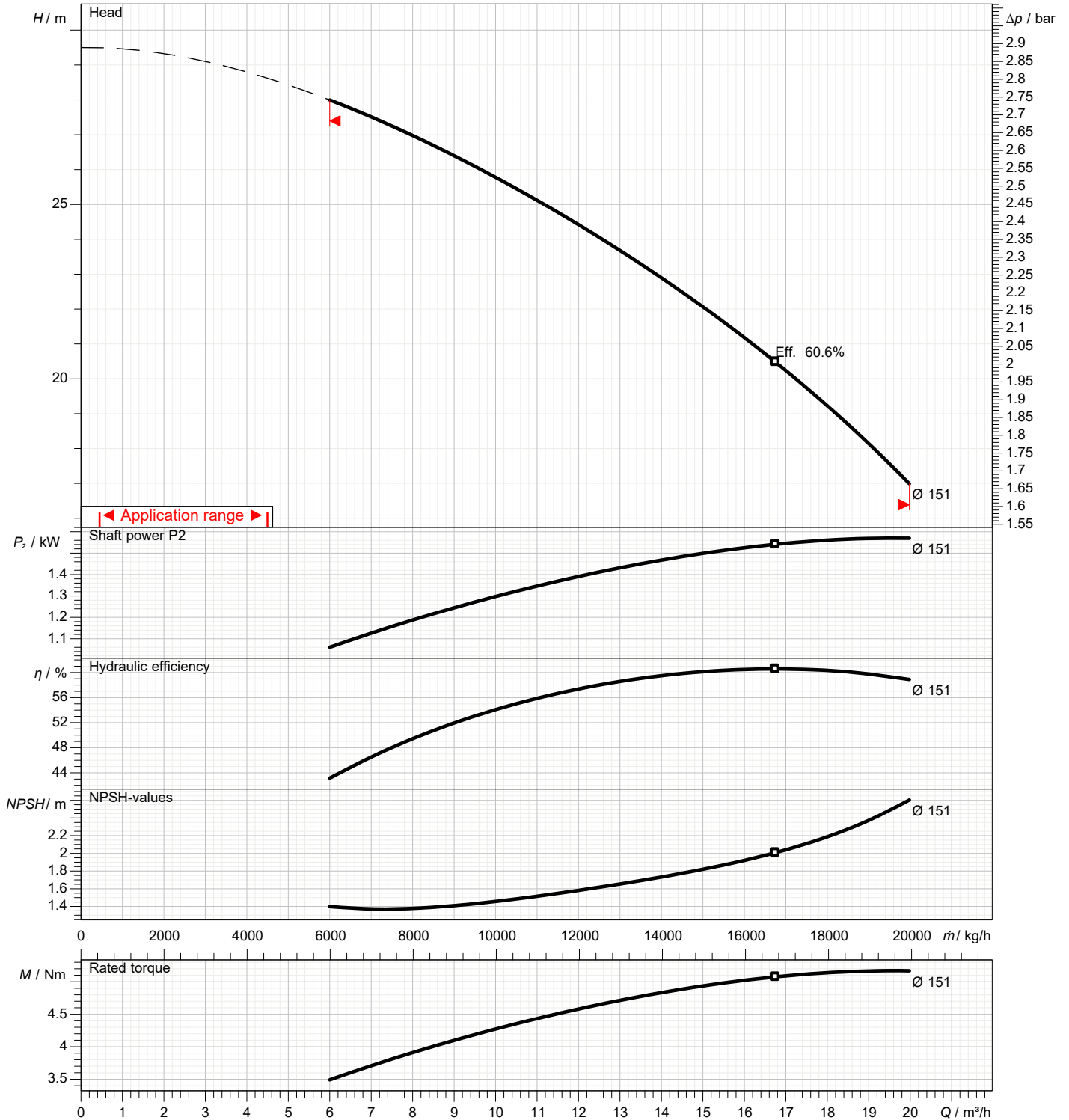

# Dimensions

Pump Name 3P 32-160/1.5

Customer	Date 2024-06-12	Company
Contact	Item no.	Issued by
Phone	Project	Phone
E-mail	Project ID Proiect redenumit 2024-06-12 12:10:37	E-mail

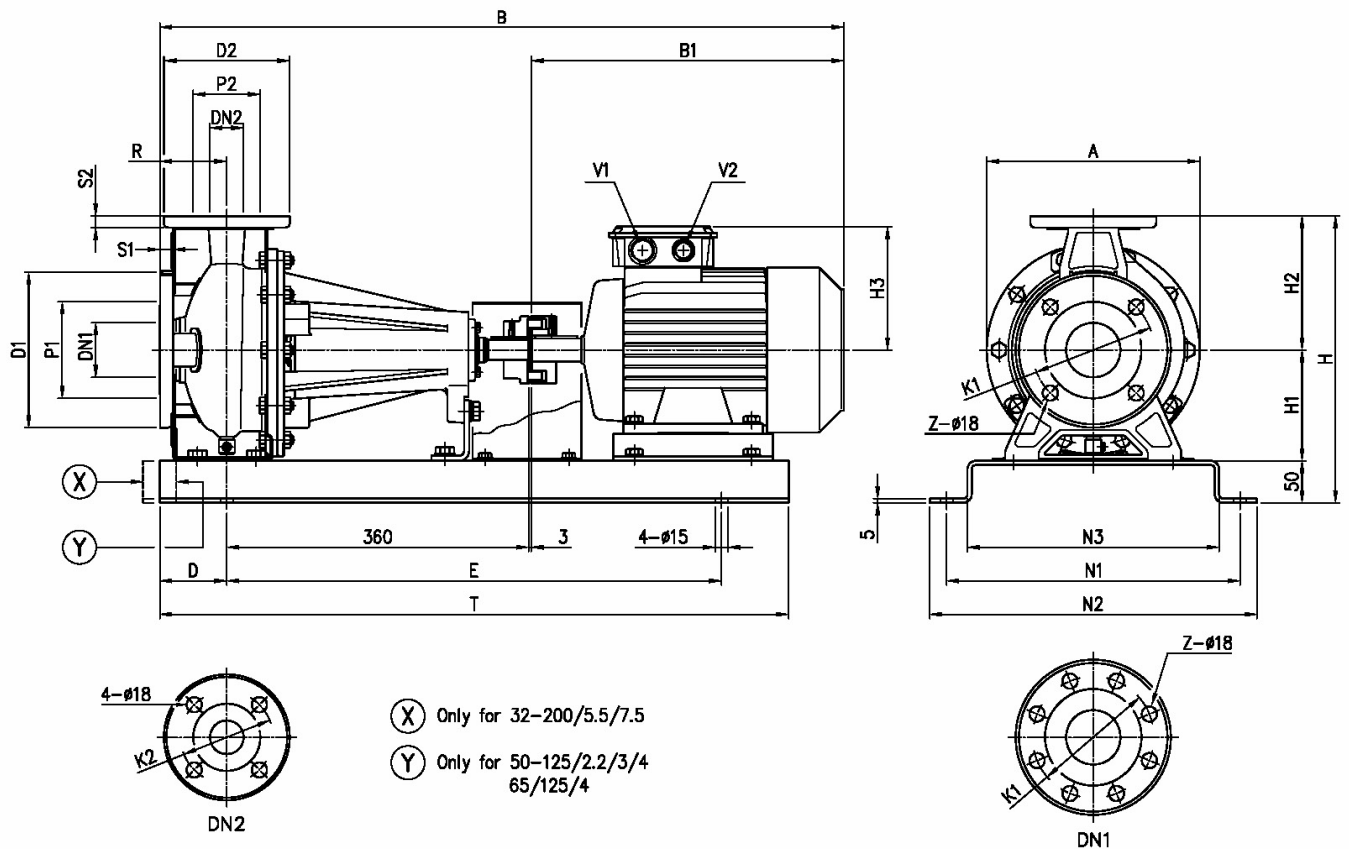

Dimensions in		mm		
1	A	254	H2	160
2	B	760	H3	148
3	B1	317	N1	350
4	D	80	N2	390
5	Dia D1	165	N3	300
6	Dia D2	140	R	80
7	Dia DN1	50	S1	16
8	Dia DN2	32	S2	14
9	Dia K1	125	T	750
10	Dia K2	100	V1	[M25x1].5
11	Dia P1	95	V2	[M20x1].5
12	Dia P2	75	Weight P&M	[52].3 kg
13	E	590	Z	4
14	H	342		
15	H1	132		

(1/3)

# Construction

Pump Name 3P 32-160/1.5

Customer	Date 2024-06-12	Company
Contact	Item no.	Issued by
Phone	Project	Phone
E-mail	Project ID Proiect redenumit 2024-06-12 12:10:37	E-mail

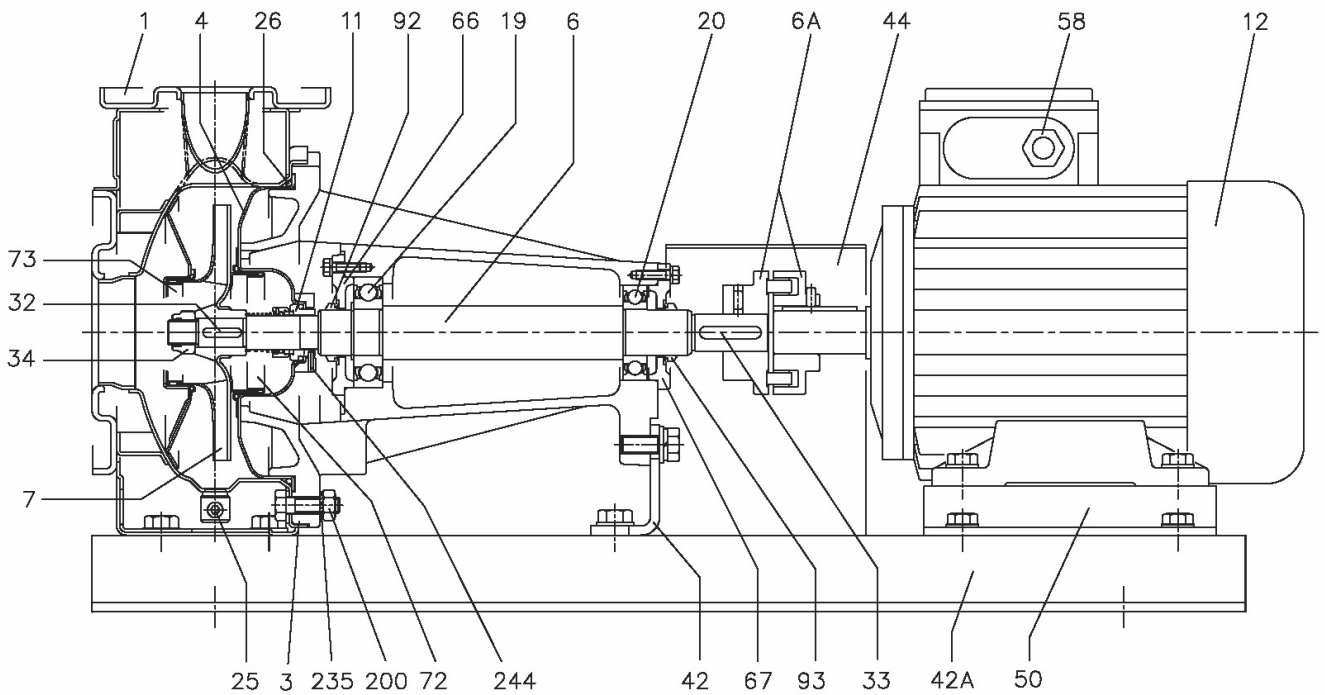

(2/3)

# Construction

Pump Name 3P 32-160/1.5

Customer	Date 2024-06-12	Company
Contact	Item no.	Issued by
Phone	Project	Phone
E-mail	Project ID Proiect redenumit 2024-06-12 12:10:37	E-mail

N°	PART NAME	MATERIAL		DIMENSIONS	STANDARD	Q.TY		
		3P	3LP					
1	Casing	EN 1.4301 (AISI 304)	EN 1.4404 (AISI 316L)			1		
3	Support	Cast iron EN-GJL-200-EN 1561				1		
4	Casing cover	EN 1.4301 (AISI 304)	EN 1.4404 (AISI 316L)			1		
6	Shaft - Part in contact with liquid	EN 1.4301 (AISI 304)	EN 1.4404 (AISI 316L)			1		
6 A	Flexible coupling	Cast iron EN-GJL-250-EN 1561				1		
7	Impeller	EN 1.4301 (AISI 304)	EN 1.4404 (AISI 316L)			1		
11	Mechanical seal	Carbon/Ceramic/NBR	SiC/SiC/FPM	[5]		1		
12	Motor	-	-			1		
19	Bearing	-	-			1		
20	Bearing	-	-			1		
25	Draing plug	EN 1.4401 (AISI 316) / PTFE		R 1/8" L=8	DIN 906	1		
26	O ring	32-125, 40-125 32-160, 40-160, 50-125, 65-125 32-200, 40-200, 50-160, 50-200, 65-160, 65-200	NBR [4]	FPM	158.11x5.34	OR 6625	1	
					183.52x5.34	OR 6720		
					227.96x5.34	OR 6895		
32	Key	Up to 11 kW 15 kW and above		EN 1.4401 (AISI 316)		6x6x25	UNI 6604	1
33	Key			C 40		8x7x30	UNI 6604	1
34	Impeller nut	Up to 11kW 50-200/15 15 kW and above	EN 1.4301 (AISI 304)	EN 1.4404 (AISI 316L)	M16x1.5	UNI 7474	1	
					M18x1.5			
					M20x1.5			
42	Pump support	Fe 37 Galvanized			EBARA DRAWING	1		
42 A	Base	Fe 37 Galvanized				1		
44	Protection	Fe 37 Galvanized				1		
50	Foot	Aluminium / Galvanized steel				1		
58	Fasting nut	-				1		
66	Impeller side bearing cover	Cast iron EN-GJL-200-EN 1561				1		
67	Motor side bearing cover	Cast iron EN-GJL-200-EN 1561				1		
72	Casing ring [1]	EN 1.4301 (AISI 304)	EN 1.4404 (AISI 316L)			1		
73	Casing ring (not for 65 version)	EN 1.4301 (AISI 304)	EN 1.4404 (AISI 316L)			1		
92	O ring	-		VS - 0030		1		
93	O ring	-		VS - 0030		1		
200	Screw	32-125, 40-125 40-160, 40-200, 50-125, 50-160, 50-200, 65-125, 65-160, 65-200	Stainless steel A2 70 class ISO 3506/1	M 8x30	UNI 5739	8		
				M 10x35	UNI 5739	[2]		
244	Pin [3]	/	EN 1.4301 (AISI 304)	4x15		1		

- [1] For version: 32-200/3, 32-200/4, 32-200/5.5, 40-200/5.5, 40-200/5.5, 40-200/7.5, 40-200/11, 50-160/5.5, 50-160/7.5, 50-200/9.2, 50-200/11, 50-200/15
- [2] Quantity =10 for 32-160, 40-160, 50-125, 65-125  
Quantity =12 for 32-200, 40-200, 50-160, 50-200, 65-160, 65-200
- [3] Only for 65-160/15 and 65-200
- [4] FPM for H-HS-HW-HSW version  
EPDM for E version and Special Seals Q1Q1EGG, Q1U3EGG, U3CEGG, Q1AEGG, U3U3EGG.  
(U3U3EGG is not available for model 65-160/15 and model 65-200)
- [5] Special version: see CONSTRUCTION 3

(3/3)

# Construction

Pump Name 3P 32-160/1.5

Customer	Date 2024-06-12	Company
Contact	Item no.	Issued by
Phone	Project	Phone
E-mail	Project ID Proiect redenumit 2024-06-12 12:10:37	E-mail

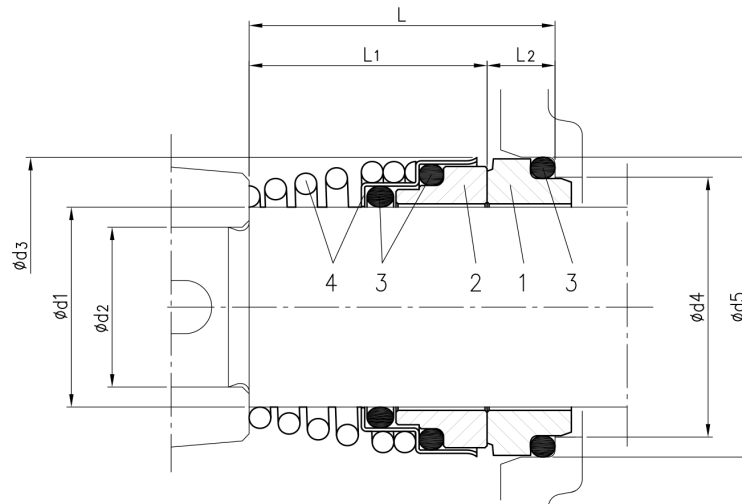

Version	Pump type	Dimensions								Material			
		d1	d2	d3	d4	d5	L	L1	L2	1 Stationary seal ring	2 Rotary seal ring	3 Rubber	4 Frame + Spring
Standard	32-125/160/200	22	19	38	31	37	37.5	27.5	10	Carbon	Ceramic	NBR	EN 1.4401 (AISI 316)
	40-125/160/200												
	50-125/160/200												
	65-125												
	65-160/7.5-9.2-11												
	65-160/15												
65-200													