

# Technical Data

Pump Name

3P 40-125/4.06

Customer	Date	2024-06-20	Company
Contact	Item no.		Issued by
Phone	Project		Phone
E-mail	Project ID	Proiect redenumit 2024-06-20 14:51:28	E-mail

## Requested data

1	Pump type	CENTRIFUGAL PUMPS	Fluid	Water
2	Number of pumps / Reserve	1 / 0	Liquid temperature	°C 20
3	Flow m <sup>3</sup> /h		Kin. viscosity	mm <sup>2</sup> /s 1.005
4	Head m		Vapour pressure	bar 0.0234
5	Geodetic head m		PH value	
6	Inlet pressure (pin) bar	0	Density	kg/m <sup>3</sup> 998.3
7	Available system NPSH		Solids	Weight % 0
8	Ambient temperature °C	20		

## Pump

9	Pump Name	3P 40-125/4.06	Frequency	Hz 60
10	Design	CENTRIFUGAL PUMPS	Installation type	STANDARD
11	Manufacturer	EBARA	Impeller Diameter	Max. mm 140
12	Speed rpm	3480		Designed mm 140
13	No. of Stage	1		Min. mm 140
14	Connection Suction side	DIN 2532	Flow	Operating m <sup>3</sup> /h
15	Connection Discharge side	DIN 2532		Max- m <sup>3</sup> /h 50
16	Max Working Pressure bar	10		Min- m <sup>3</sup> /h 12
17	Shut-off head bar	3.72	Head	Operating m
18	Total weight kg	See the table of "Dimensions".		- (Qmax.) m 20.0
19	Shaft power kW			- (Qmin.) m 37.3
20			Max. Shaft Power at max. impeller	kW 4.12
21	Required pump NPSH m		Efficiency	%

## Materials

22	Impeller	AISI 304	
23	Casing	AISI 304	
24	Shaft	AISI 304	
25			
26			
27			

## Motor

28	Manufacturer	LAFERT	Insulation class	F
29	Type	TEFC_3P 40-125/4.06_265_Three Phase	Phases	3~
30	Specific design	IE2 / 60 Hz / Pole pairs 1	Frame size	
31	Rated power kW	4	Weight	kg
32	Number of poles	2	Electric voltage	V 265
33	Speed rpm	3500	Electric current	A 10.9
34	Degree of protection	IP 55		
35				

## Remarks

# Performance Curve

Pump Name

3P 40-125/4.06

Customer	Date	2024-06-20	Company
Contact	Item no.		Issued by
Phone	Project		Phone
E-mail	Project ID	Project redenumit 2024-06-20 14:51:28	E-mail

**Requested data**

1	Flow	m³/h	
2	Head	m	
3	Geodetic head	m	

**Pump**

Operating flow	m³/h		Frequency	Hz	60
Operating head	m		Number of poles		2
Impeller diameter designed	mm	140	Speed	rpm	3480

Test standard: ISO 9906:2012 - Grade3B

Water; 20°C; 998.3kg/m³; 1mm²/s

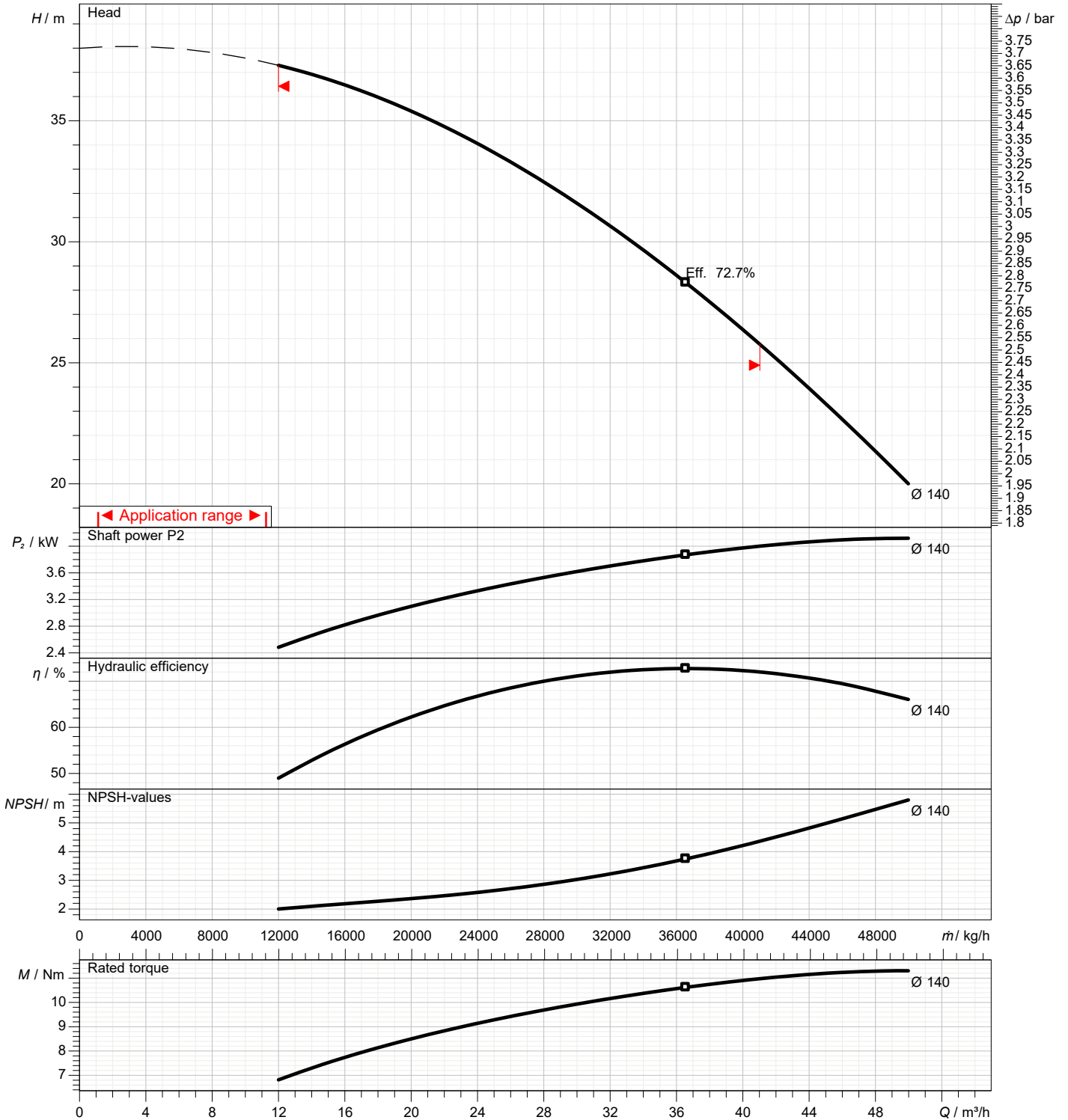

# Dimensions

Pump Name 3P 40-125/4.06

Customer	Date 2024-06-20	Company
Contact	Item no.	Issued by
Phone	Project	Phone
E-mail	Project ID Proiect redenumit 2024-06-20 14:51:28	E-mail

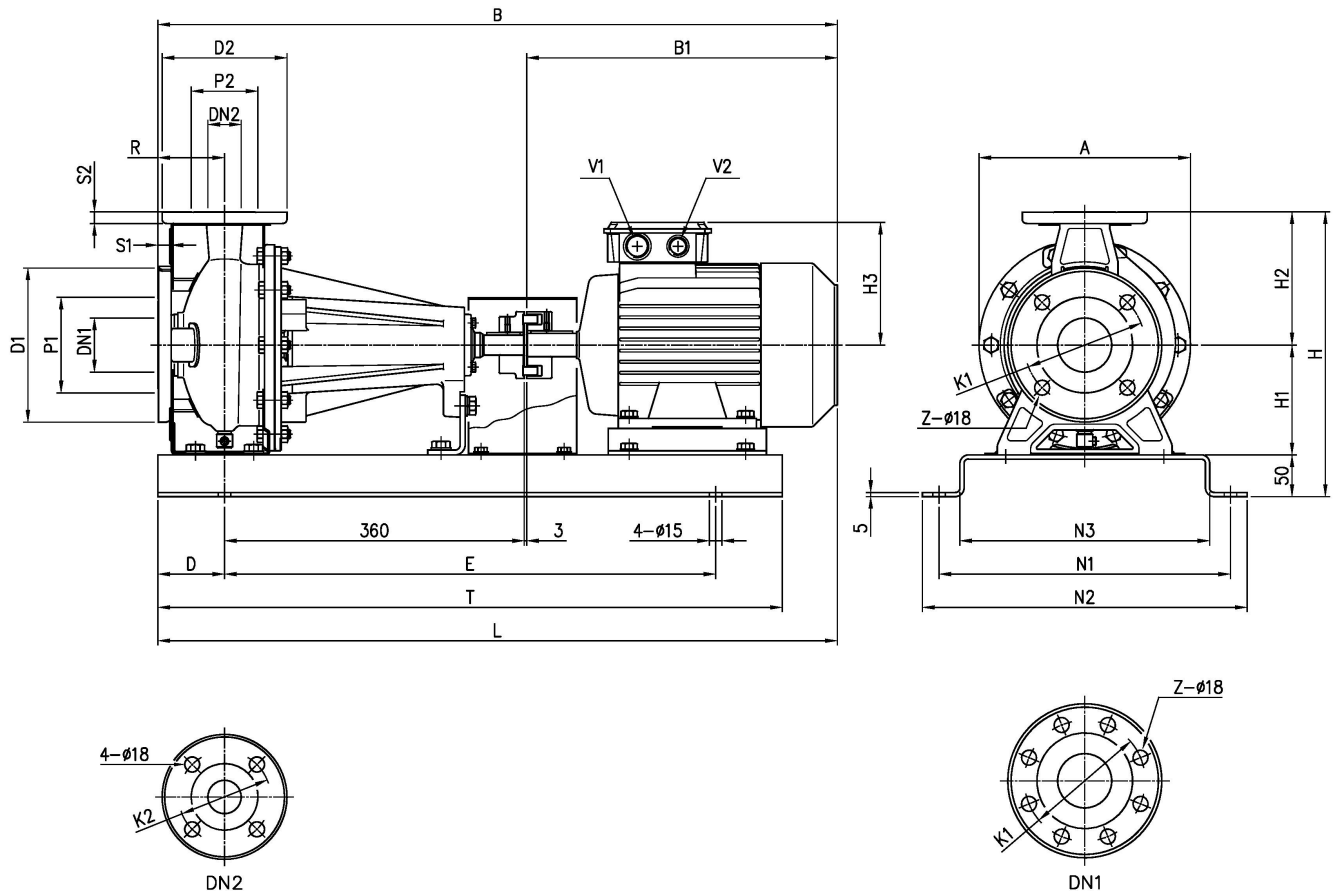

Dimensions in		mm		
1	A	213	H2	140
2	B	831	H3	171
3	B1	388	L	831
4	D	80	N1	300
5	Dia D1	185	N2	340
6	Dia D2	150	N3	250
7	Dia DN1	65	R	80
8	Dia DN2	40	S1	16
9	Dia K1	145	S2	14
10	Dia K2	110	T	750
11	Dia P1	115	V1	M25x1,5
12	Dia P2	80	V2	M20x1,5
13	E	590	Weight P&M	66,6 kg
14	H	302	Z	4
15	H1	112		

(1/3)

# Construction

Pump Name 3P 40-125/4.06

Customer	Date 2024-06-20	Company
Contact	Item no.	Issued by
Phone	Project	Phone
E-mail	Project ID Proiect redenumit 2024-06-20 14:51:28	E-mail

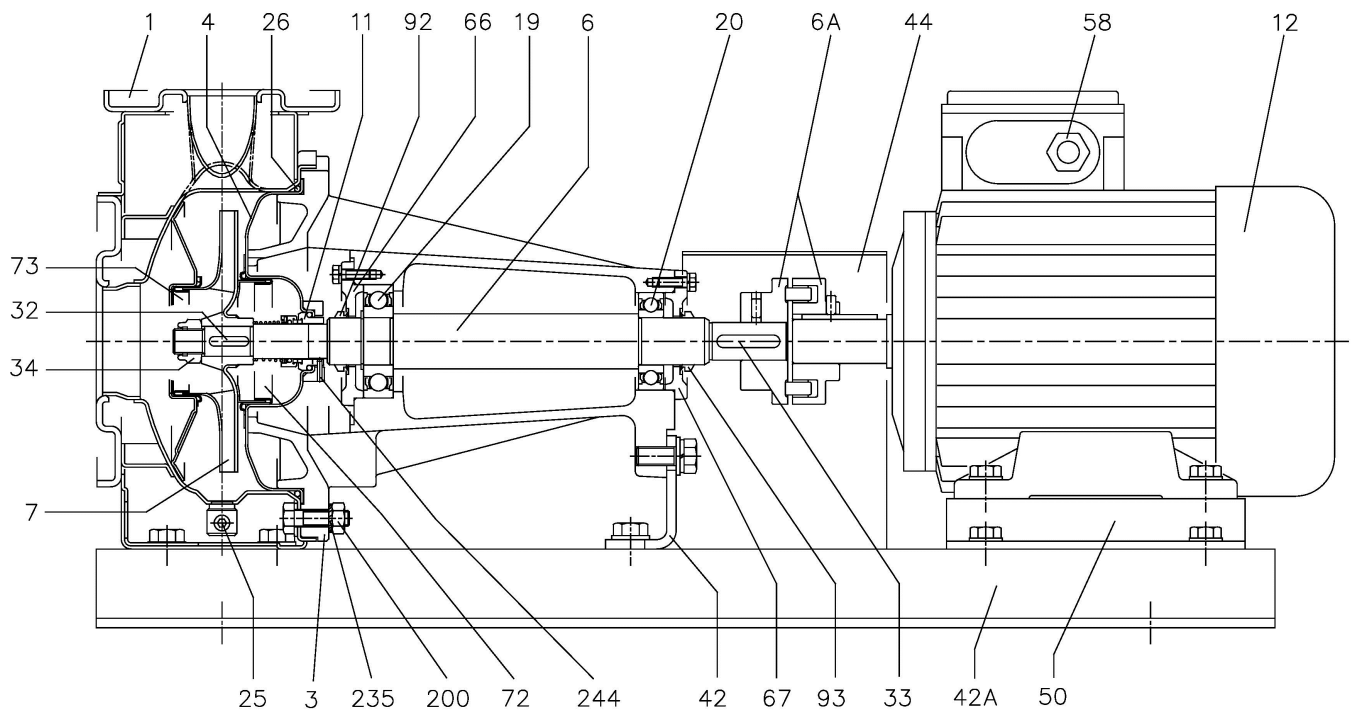

(2/3)

# Construction

Pump Name 3P 40-125/4.06

Customer	Date 2024-06-20	Company
Contact	Item no.	Issued by
Phone	Project	Phone
E-mail	Project ID Proiect redenumit 2024-06-20 14:51:28	E-mail

(3/3)

# Construction

Pump Name 3P 40-125/4.06

Customer	Date 2024-06-20	Company
Contact	Item no.	Issued by
Phone	Project	Phone
E-mail	Project ID Proiect redenumit 2024-06-20 14:51:28	E-mail

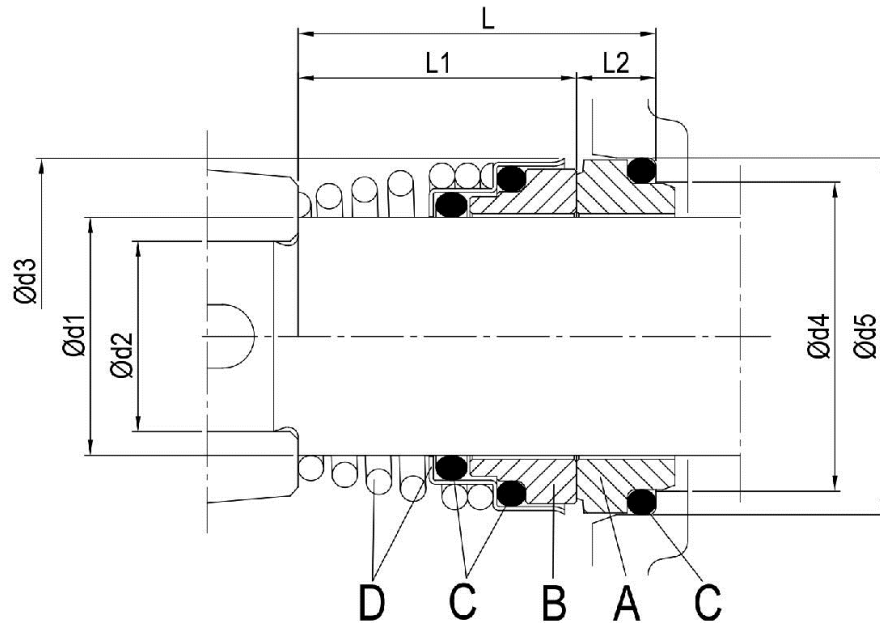

Pump type	Dimensions [mm]								Material Standard			
	d1	d2	d3	d4	d5	L	L1	L2	A Stationary seal ring	B Rotary seal ring	C O-ring	D Frame + spring
32-125/160/200 40-125/160/200 50-125/160 65-125 65-160/7.56-9.26-116	22	19	38	31	37	37.5	27.5	10	Carbon	Ceramic	NBR	EN 1.4301 (AISI 304)