

# Technical Data

Pump Name

3SF 50-125/4.0

Customer	Date	2024-06-12	Company
Contact	Item no.		Issued by
Phone	Project		Phone
E-mail	Project ID	Proiect redenumit 2024-06-12 12:10:37	E-mail

## Requested data

1	Pump type	CENTRIFUGAL PUMPS	Fluid	Water
2	Number of pumps / Reserve	1 / 0	Liquid temperature	°C
3	Flow	m³/h	Kin. viscosity	mm²/s
4	Head	m	Vapour pressure	bar
5	Geodetic head	m	PH value	
6	Inlet pressure (pin)	bar	Density	kg/m³
7	Available system NPSH		Solids	Weight %
8	Ambient temperature	°C		

## Pump

9	Pump Name	3SF 50-125/4.0	Frequency	Hz	50	
10	Design	CENTRIFUGAL PUMPS	Installation type		STANDARD	
11	Manufacturer	EBARA	Impeller Diameter	Max.	mm	
12	Speed	rpm		2900	Designed	mm
13	No. of Stage	1		Min.	mm	140
14	Connection	Suction side	DIN 2532	Flow	Operating	m³/h
15	Connection	Discharge side	DIN 2532		Max-	m³/h
16	Max Working Pressure	bar	10		Min-	m³/h
17	Shut-off head	bar	2.59	Head	Operating	m
18	Total weight	kg	See the table of "Dimensions".		- (Qmax.)	m
19	Shaft power	kW			- (Qmin.)	m
20				Max. Shaft Power at max. impeller	kW	4.07
21	Required pump NPSH	m		Efficiency	%	

## Materials

22	Impeller	AISI 304		
23	Casing	AISI 304		
24	Shaft	AISI 304		
25				
26				
27				

## Motor

28	Manufacturer	without motor	Insulation class	
29	Type	without motor 3	Phases	
30	Specific design	without motor / 50 Hz / Pole pairs 1	Frame size	
31	Rated power	kW	Weight	kg
32	Number of poles	2	Electric voltage	V
33	Speed	rpm	Electric current	A
34	Degree of protection			
35				

## Remarks

# Performance Curve

Pump Name

3SF 50-125/4.0

Customer	Date	2024-06-12	Company
Contact	Item no.		Issued by
Phone	Project		Phone
E-mail	Project ID	Project redenumit 2024-06-12 12:10:37	E-mail

## Requested data

1	Flow	m³/h	
2	Head	m	
3	Geodetic head	m	

## Pump

Operating flow	m³/h		Frequency	Hz	50
Operating head	m		Number of poles		2
Impeller diameter designed	mm	140	Speed	rpm	2900

Test standard: ISO 9906:2012 - Grade3B

Water; 20°C; 998.3kg/m³; 1mm²/s

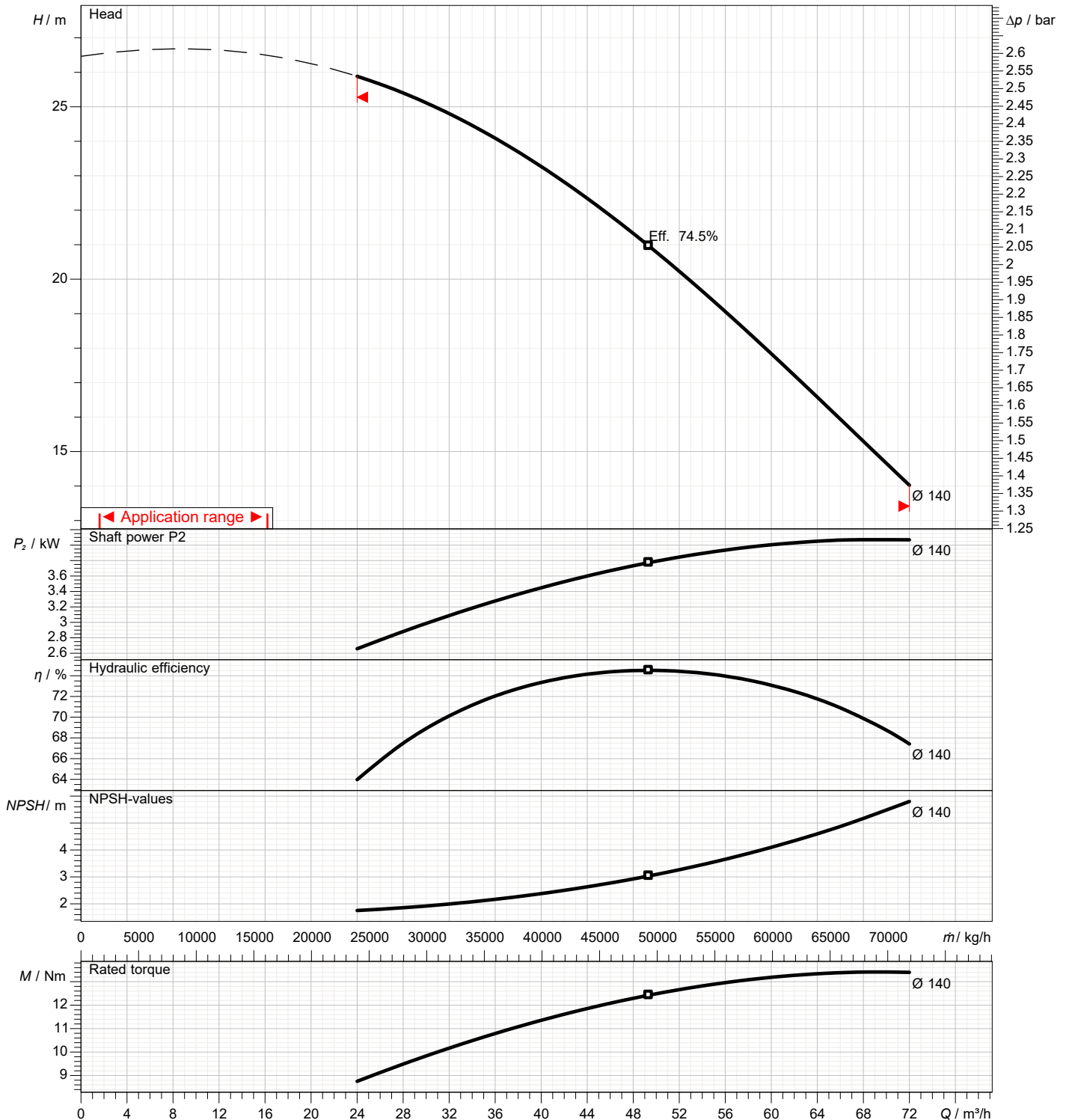

# Dimensions

Pump Name 3SF 50-125/4.0

Customer	Date 2024-06-12	Company
Contact	Item no.	Issued by
Phone	Project	Phone
E-mail	Project ID Proiect redenumit 2024-06-12 12:10:37	E-mail

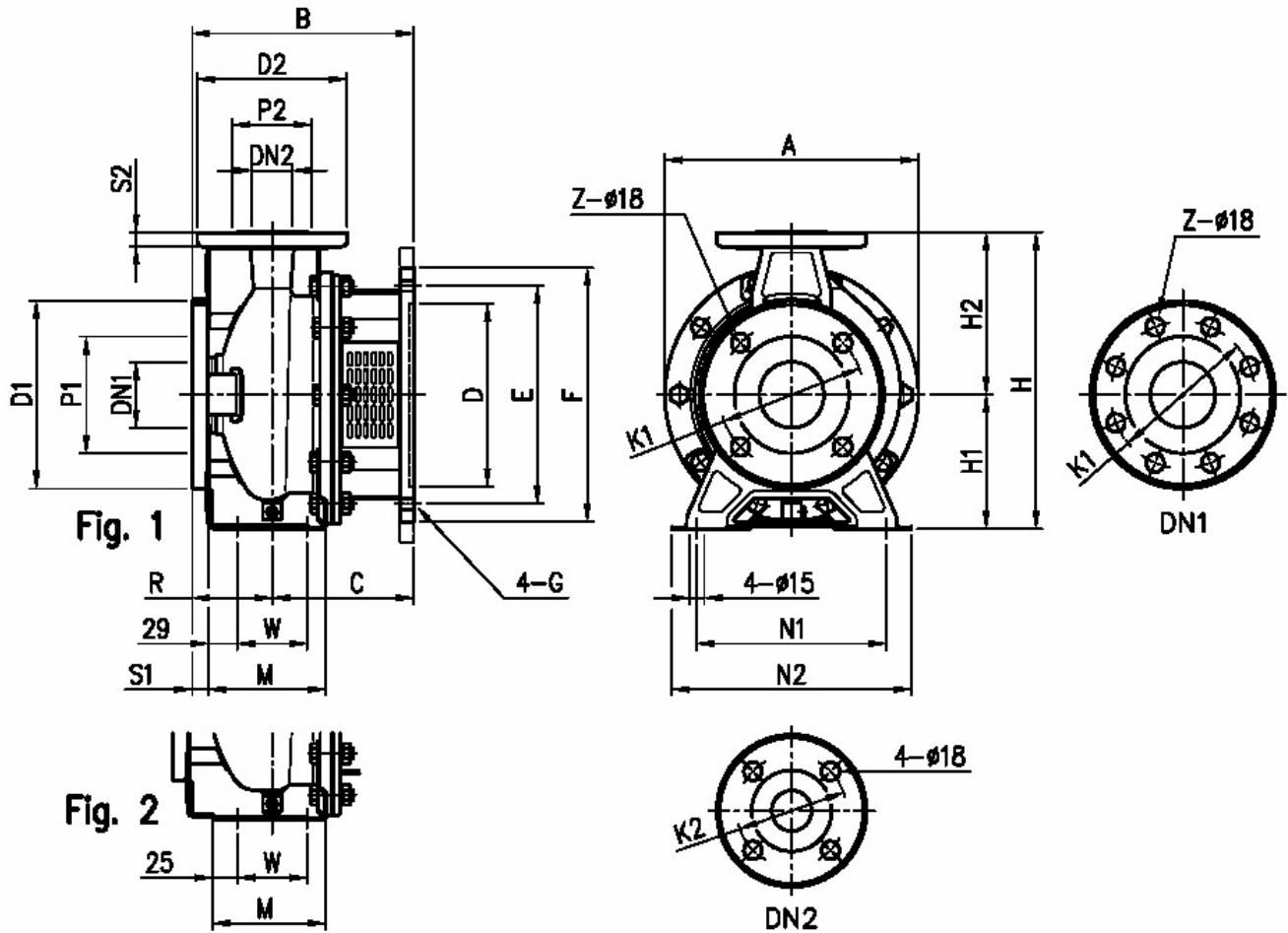

Dimensions in		mm						
1	A	254	G	M12				
2	B	242	H	292				
3	C	142	H1	132				
4	D	180	H2	160				
5	Dia D1	185	M	114				
6	Dia D2	165	N1	190				
7	Dia DN1	65	N2	240				
8	Dia DN2	50	R	100				
9	Dia K1	145	S1	16				
10	Dia K2	125	S2	16				
11	Dia P1	115	W	70				
12	Dia P2	95	Weight PUMP	20 kg				
13	E	215	Z	4				
14	F	250						
15	Fig	2						

(1/3)

# Construction

Pump Name 3SF 50-125/4.0

Customer	Date 2024-06-12	Company
Contact	Item no.	Issued by
Phone	Project	Phone
E-mail	Project ID Proiect redenumit 2024-06-12 12:10:37	E-mail

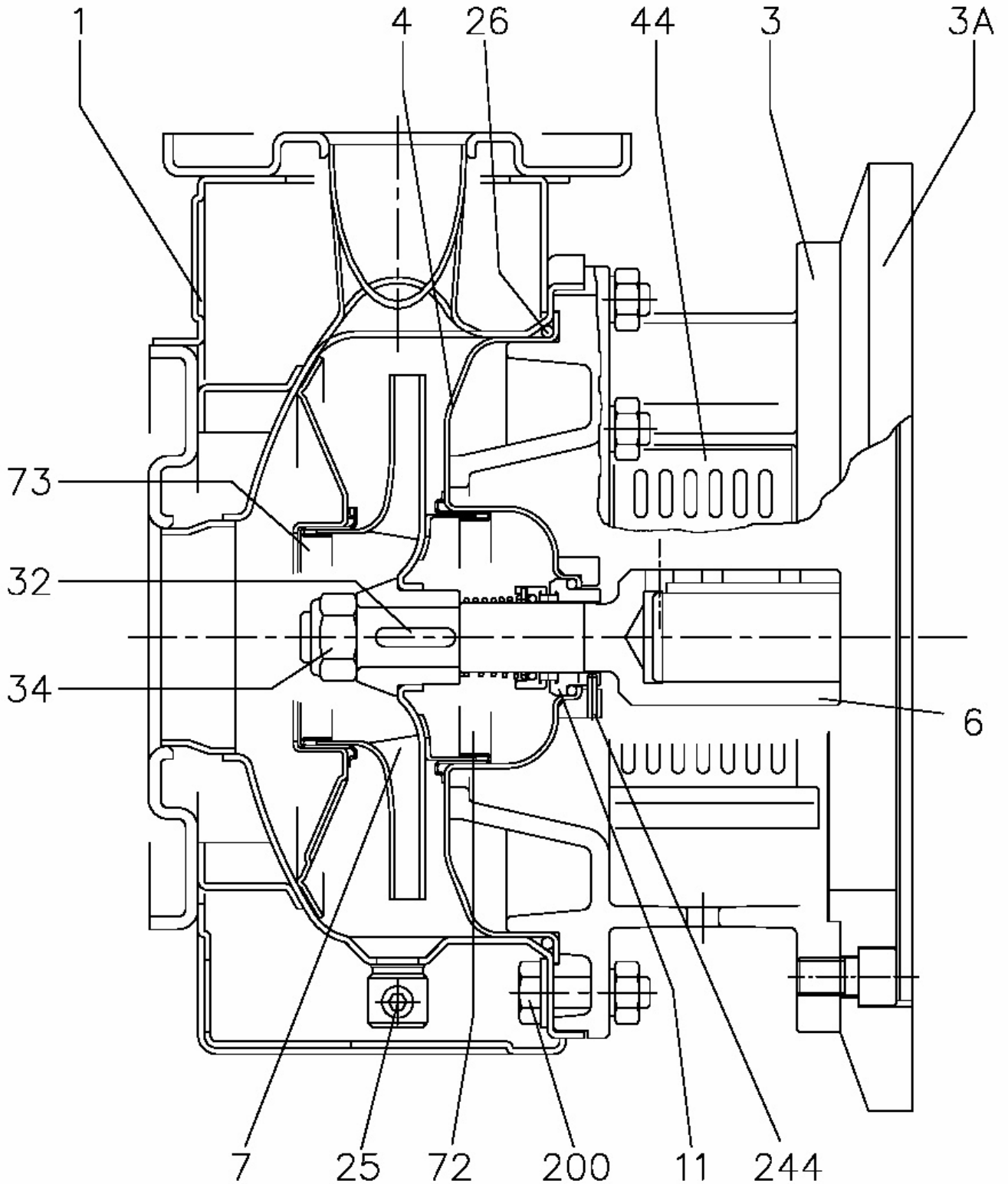

(2/3)

# Construction

Pump Name 3SF 50-125/4.0

Customer	Date 2024-06-12	Company
Contact	Item no.	Issued by
Phone	Project	Phone
E-mail	Project ID Proiect redenumit 2024-06-12 12:10:37	E-mail

N°	PART NAME	MATERIAL		DIMENSIONS	STANDARD	Q.TY	
		3SF	3LSF				
1	Casing	EN 1.4301 (AISI 304)	EN 1.4404 (AISI 316L)			1	
3	Motor bracket	Cast iron EN-G JL-200-EN 1561				1	
3A	Adapler ring [1]	Cast iron EN-G JL-200-EN 1561				1	
4	Casing cover	EN 1.4301 (AISI 304)	EN 1.4404 (AISI 316L)			1	
6	Coupling - Part in contact with liquid	EN 1.4301 (AISI 304)	EN 1.4404 (AISI 316L)			1	
7	Impeller	32,40,50 65-125/160/200	EN 1.4301 (AISI 304) EN 1.4404 (AISI 316L) EN 1.4401 (AISI 316)			1	
11	Mechanical seal [5]	Carbon/Ceramic/NBR	SIC/SIC/FPM			1	
25	Draing plug	EN 1.4401 (AISI 316) / PTFE		R 1/8" L=8	DIN 906	1	
26	O ring	32-125, 40-125 32-160, 40-160, 50-125, 65-125 32-200, 40-200, 50-160, 50-200, 65-160, 65-200	NBR [6]	FPM	158.11x5.34	OR 6625	1
					183.52x5.34	OR 6720	
					227.96x5.34	OR 6895	
32	Key	Up to 11 kW 15 kW and above	EN 1.4301 (AISI 304)	EN 1.4401 (AISI 316)	6x6x25	UNI 6604	1
					8 x7x 30		
34	Impeller nut	Up to 11kW 50-200/15 15 kW and above	EN 1.4301 (AISI 304)	EN 1.4404 (AISI 316L)	M16x1.5	UNI 7474	1
					M18x1.5		
					M20x1.5		
44	Protection	EN 1.4301 (AISI 304)			EBARA DRAWING	1	
72	Casing ring [2]	EN 1.4301 (AISI 304)	EN 1.4404 (AISI 316L)			1	
73	Casing ring (not for 65 version)	EN 1.4301 (AISI 304)	EN 1.4404 (AISI 316L)			1	
200	Screw	32-125, 40-125 40-160, 40-200, 50-125, 50-160, 50-200, 65-125, 65-160, 65-200	Stainless steel A2 70 class ISO 3506/ 1		M 8x30	UNI 5739	8
					M 10x35	UNI 5739	[3]
244	Pin [4]	/	EN 1.4301 (AISI 304)	4x15		1	

[1] Only for 65-125/5.5 and 65-125/7.5

[2] For version 32-200, 40-200, 50-160, 50-200

[3] Quantity=10 for 32-160, 40-160, 50-125, 65-125

Quantity=12 for 32-200, 40-200, 50-160, 50-200, 65-160, 65-200

[4] Only for 65-160/15 and 65-200

[5] FPM for H-HS-HW-HSW version

EPDM for E version, Q1AEGG, Q1U3EGG, U3CEGG, Q1Q1EGG

U3U3EGG not available for models 65-160/15 and 65-200

# (3/3) Construction

Pump Name 3SF 50-125/4.0

Customer	Date 2024-06-12	Company
Contact	Item no.	Issued by
Phone	Project	Phone
E-mail	Project ID Proiect redenumit 2024-06-12 12:10:37	E-mail

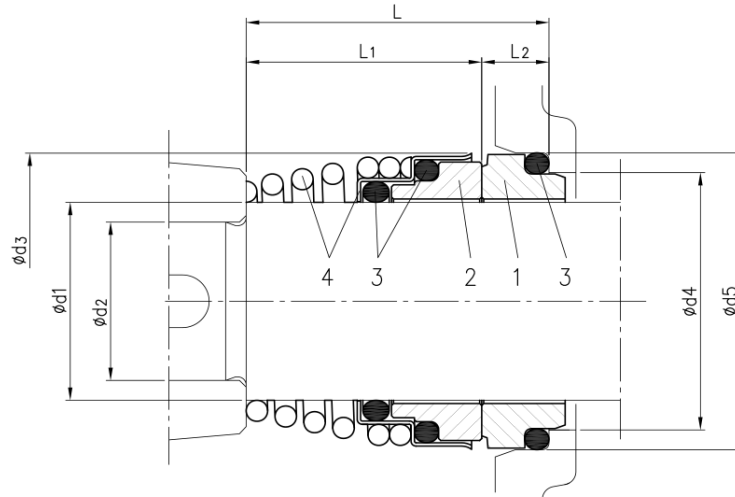

Version	Pump type	Dimensions							Material				
		d1	d2	d3	d4	d5	L	L1	L2	1 Stationary seal ring	2 Rotary seal ring	3 Rubber	4 Frame + spring
Standard	32-125/160/200												
	40-125/160/200												
	50-125/160/200	22	19	38	31	37	37.5	27.5	10	Carbon	Ceramic	NBR	EN 1.4401 (AISI 316)
	65-125												
	65-160/7.5-9.2-11												
65-160/15	30	24	46	39	45	42.5	32.5	10					
	65-200												