

# Technical Data

Pump Name

80 DL 53.7

Customer	Date	2024-06-13	Company
Contact	Item no.		Issued by
Phone	Project		Phone
E-mail	Project ID	Project redenumit 2024-06-13 13:12:02	E-mail

## Requested data

1	Pump type		SUBMERSIBLE SEWAGE PUMP-Non-clog	Fluid		Water
2	Number of pumps / Reserve	1 / 0		Liquid temperature	°C	20
3	Flow	m³/h		Kin. viscosity	mm²/s	1.005
4	Head	m		Vapour pressure	bar	0.0234
5	Geodetic head	m		PH value		
6	Inlet pressure (pin)	bar	0	Density	kg/m³	998.3
7	Available system NPSH			Solids	Weight %	0
8	Ambient temperature	°C	20			

## Pump

9	Pump Name		80 DL 53.7	Frequency	Hz	50
10	Design		SUBMERSIBLE SEWAGE PUMP-Non-clog	Installation type		STANDARD
11	Manufacturer		EBARA	Impeller Diameter	Max. mm	242
12	Speed	rpm	1450		Designed mm	242
13	No. of Stage		1		Min. mm	242
14	Connection	Suction side		Flow	Operating m³/h	
15	Connection	Discharge side	JIS 10K		Max- m³/h	72
16	Max Working Pressure	bar			Min- m³/h	6
17	Shut-off head	bar	1.92	Head	Operating m	
18	Total weight	kg	See the table of "Dimensions".		- (Qmax.) m	10.4
19	Shaft power	kW			- (Qmin.) m	19.1
20				Max. Shaft Power at max. impeller	kW	3.68
21	Required pump NPSH	m		Efficiency	%	

## Materials

22	Casing		FC200	Mechanical seal (Lower)		SiC/SiC
23	Suction Cover		FC200	Lubricating Oil		Turbine Oil VG32
24	Impeller		FC200			
25	Shaft		SUS403			
26	Motor frame		FC150			
27	Mechanical seal (Upper)		Carbon/Ceramic			

## Motor

28	Manufacturer		--	Insulation class		F
29	Type		DL 53.7_380_Three phase	Phases		3~
30	Specific design		Submersible dry type / 50 Hz / Pole pairs 2	Frame size		
31	Rated power	kW	3.7	Weight	kg	
32	Number of poles		4	Electric voltage	V	380
33	Speed	rpm	1427	Electric current	A	8.4
34	Degree of protection		IP68			
35						

## Remarks

# Performance Curve

Pump Name

80 DL 53.7

Customer	Date	2024-06-13	Company
Contact	Item no.		Issued by
Phone	Project		Phone
E-mail	Project ID	Proiect redenumit 2024-06-13 13:12:02	E-mail

**Requested data**

1	Flow	m³/h	
2	Head	m	
3	Geodetic head	m	

**Pump**

Operating flow	m³/h		Frequency	Hz	50
Operating head	m		Number of poles		4
Impeller diameter designed	mm	242	Speed	rpm	1450

Test standard: ISO 9906:2012 - Grade3B

Water; 20°C; 998.3kg/m³; 1mm²/s

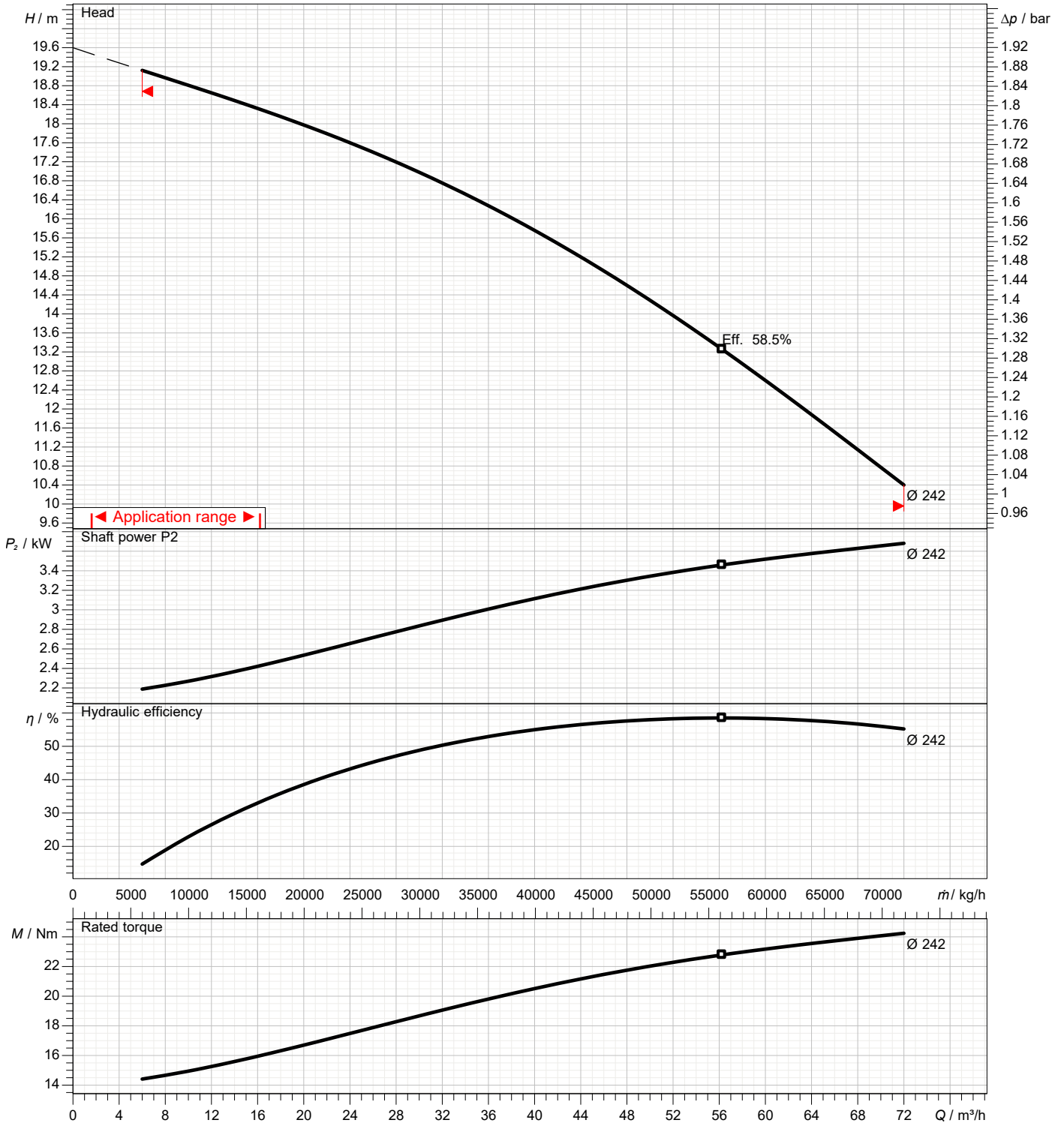

# Dimensions

Pump name

80 DL 53.7

Customer	Date	2024-06-13	Company
Contact	Item no.		Issued by
Phone	Project		Phone
E-mail	Project ID	Project redenumit 2024-06-13 13:12:02	E-mail

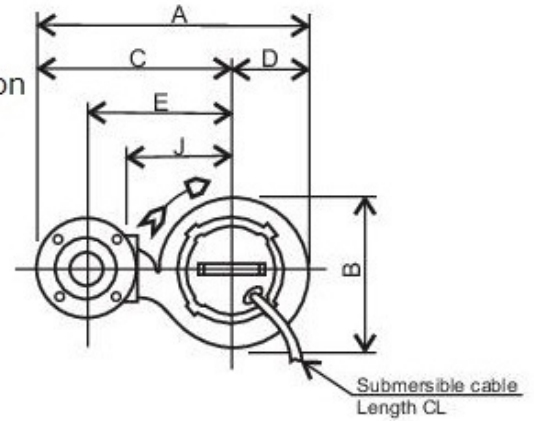
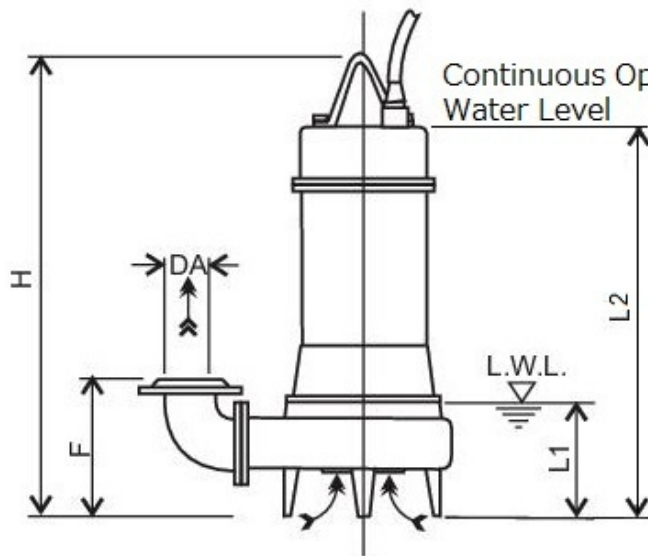

- Note:
- 1/. Operation is limited to 10 minutes at L.W.L.(Low Water Level).
  - 2/. Operation is limited 30 minutes with water level below top of motor

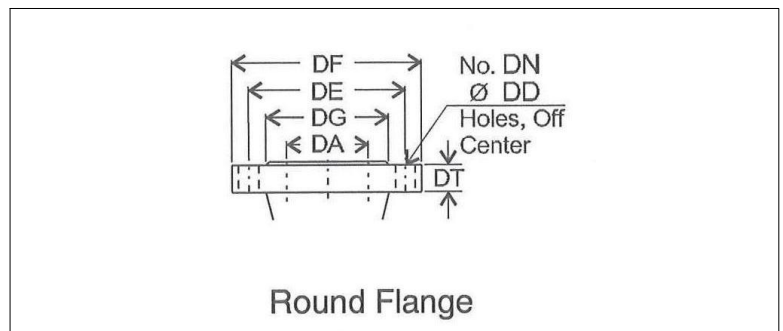

Pump dimensions		mm		Suction side		mm		Discharge side		mm	
A	567					DA	80				
B	328					DD	15				
C	403					DE	150				
CL	10m					DF	185				
D	164					DG	126				
E	310					DN	8 (Num)				
F	220					DT	18				
H	687										
J	235										
L1	165										
L2	587										

# Construction

Pump name

80 DL 53.7

Customer	Date 2024-06-13	Company
Contact	Item no.	Issued by
Phone	Project	Phone
E-mail	Project ID Proiect redenumit 2024-06-13 13:12:02	E-mail

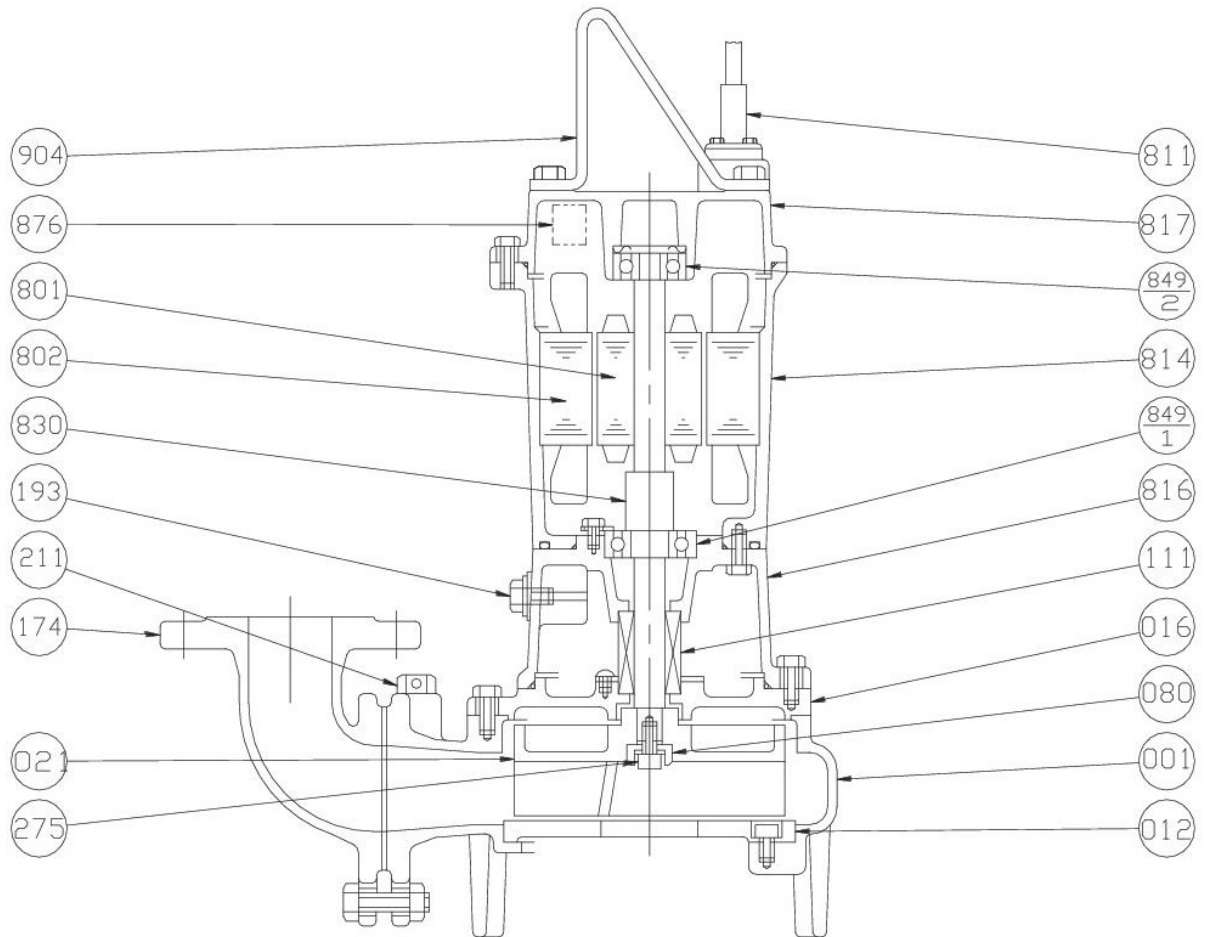

Item Number	Description	Material	Quantity per unit
001	Pump Casing	FC200 Cast iron	1
012	Suction Cover	FC200 Cast iron	1
016	Mechanical Seal Cover	FC200 Cast iron	1
021	Impeller	FC200 Cast iron	1
080	Bushing	SS Steel	1
111	Mechanical Seal		1
174	Discharge Bend	FC200 Cast iron	1
193	Oil Plug	C3604 or SUS304 Brass or 304 Stainless Steel	1
211	Airvent Valve	C3604 Brass	1
275	Impeller Bolt	SUS304 Stainless Steel	1

Item Number	Description	Material	Quantity per unit
801	Rotor		1
802	Stator		1
811	Submersible Cable		1
814	Motor Frame	FC150 Cast Iron	1
816	Power Side Bracket	FC150 Cast Iron	1
817	Opposite Side Bracket	FC150 Cast Iron	1
830	Shaft	SUS403 Stainless Steel	1
849-1	Ball Bearing		1
849-2	Ball Bearing		1
876	Protector		1
904	Lifting Hanger	SS Steel	1