

Technical Data

Pump Name

CDM 120/07

Customer	Date	2024-06-13	Company
Contact	Item no.		Issued by
Phone	Project		Phone
E-mail	Project ID	Proiect redenumit 2024-06-13 13:12:02	E-mail

Requested data

1	Pump type	CENTRIFUGAL PUMPS	Fluid	Water
2	Number of pumps / Reserve	1 / 0	Liquid temperature	°C 20
3	Flow m³/h		Kin. viscosity	mm²/s 1.005
4	Head m		Vapour pressure	bar 0.0234
5	Geodetic head m		PH value	
6	Inlet pressure (pin) bar	0	Density	kg/m³ 998.3
7	Available system NPSH		Solids	Weight % 0
8	Ambient temperature °C	20		

Pump

9	Pump Name	CDM 120/07	Frequency	Hz 50
10	Design	CENTRIFUGAL PUMPS	Installation type	STANDARD
11	Manufacturer	EBARA	Impeller Diameter	Max. mm 132
12	Speed rpm	2800		Designed mm 132
13	No. of Stage	1		Min. mm 132
14	Connection Suction side	UNI ISO 228-1	Flow	Operating m³/h
15	Connection Discharge side	UNI ISO 228-1		Max- m³/h 10.8
16	Max Working Pressure bar	8		Min- m³/h 3
17	Shut-off head bar	2.20	Head	Operating m
18	Total weight kg	See the table of "Dimensions".		- (Qmax.) m 12.5
19	Shaft power kW			- (Qmin.) m 20.5
20			Max. Shaft Power at max. impeller	kW 0.65
21	Required pump NPSH m		Efficiency	%

Materials

22	Impeller	AISI 304		
23	Casing	AISI 304		
24	Shaft	AISI 303 (Wet extension)		
25				
26				
27				

Motor

28	Manufacturer	EPE Standard	Insulation class	F
29	Type	TEFC_CDM 120/07_230_Single Phase	Phases	1~
30	Specific design	IE2 / 50 Hz / Pole pairs 1	Frame size	
31	Rated power kW	0.9	Weight	kg
32	Number of poles	2	Electric voltage	V 230
33	Speed rpm	2800	Electric current	A 4.4
34	Degree of protection	IP 55		
35				

Remarks

Performance Curve

Pump Name

CDM 120/07

Customer	Date	2024-06-13	Company
Contact	Item no.		Issued by
Phone	Project		Phone
E-mail	Project ID	Project redenumit 2024-06-13 13:12:02	E-mail

Requested data

1	Flow	m³/h	
2	Head	m	
3	Geodetic head	m	

Pump

Operating flow	m³/h		Frequency	Hz	50
Operating head	m		Number of poles		2
Impeller diameter designed	mm	132	Speed	rpm	2800

Test standard: ISO 9906:2012 - Grade3B

Water; 20°C; 998.3kg/m³; 1mm²/s

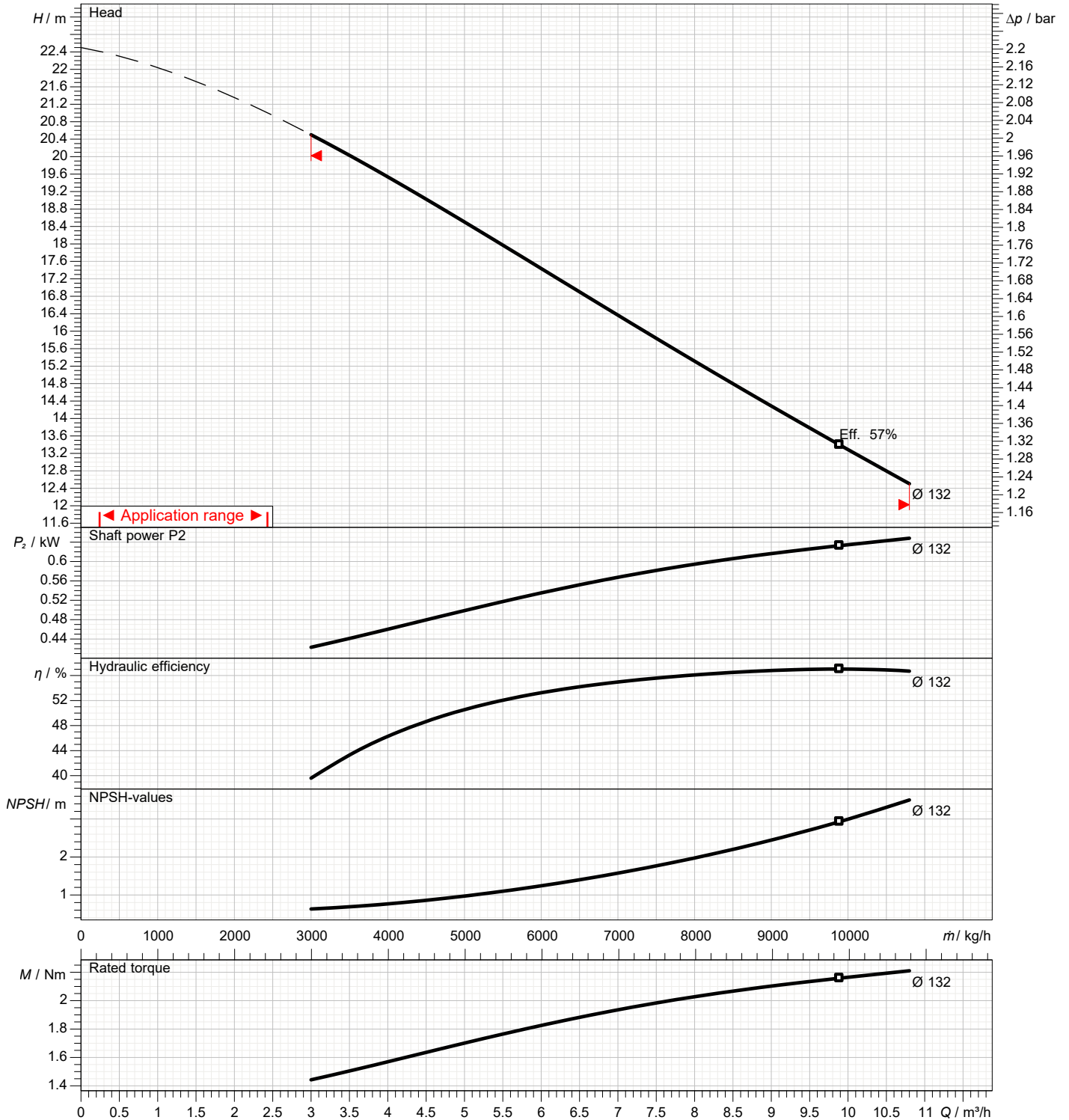

Dimensions

Pump Name CDM 120/07

Customer	Date 2024-06-13	Company
Contact	Item no.	Issued by
Phone	Project	Phone
E-mail	Project ID Proiect redenumit 2024-06-13 13:12:02	E-mail

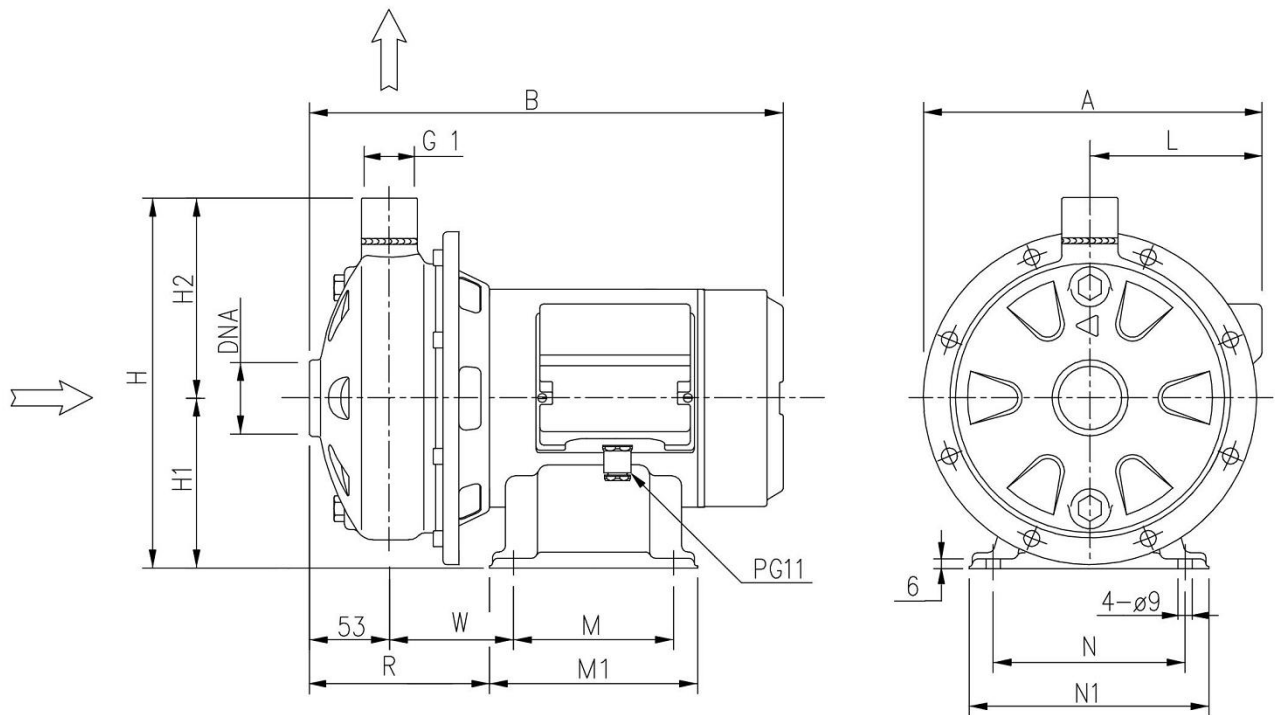

Dimensions in		mm						
1	A	209						
2	B	328						
3	DNA	G 1" 1/4						
4	H	229.5						
5	H1	106						
6	H2	123.5						
7	L	105						
8	M	100						
9	M1	130						
10	N	120						
11	N1	150						
12	R	115.5						
13	W	77.5						
14	Weight P&M	10kg						
15								

(1/3)

Construction

Pump Name CDM 120/07

Customer	Date 2024-06-13	Company
Contact	Item no.	Issued by
Phone	Project	Phone
E-mail	Project ID Proiect redenumit 2024-06-13 13:12:02	E-mail

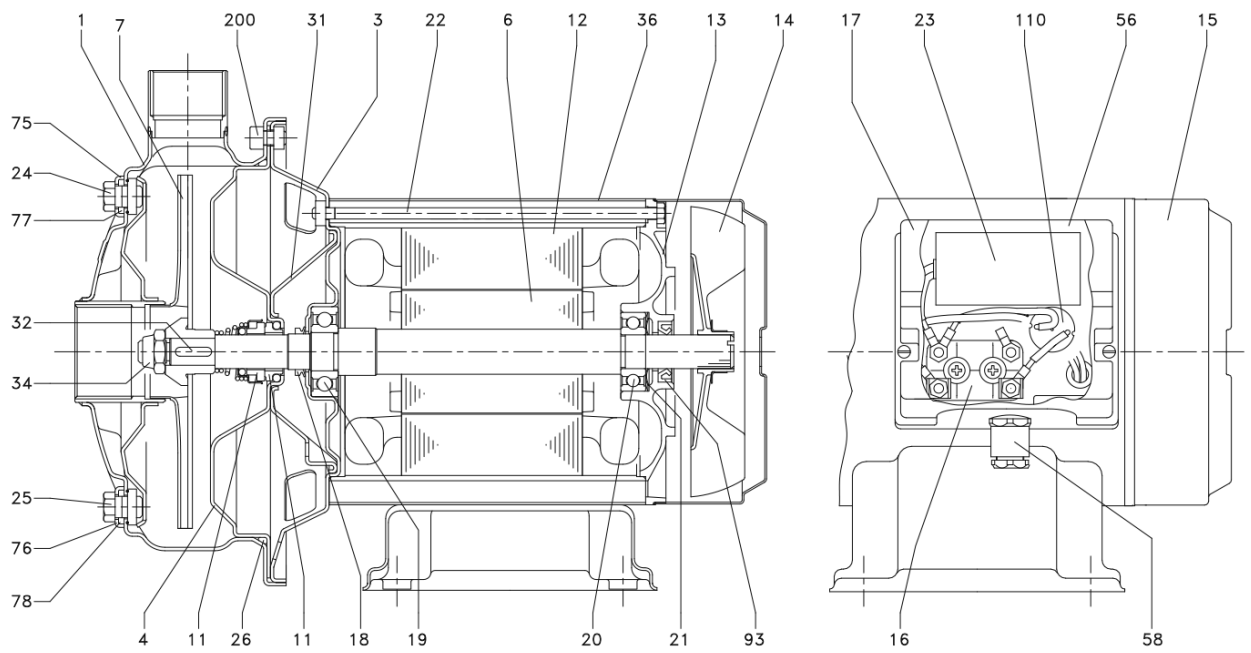

(2/3)

Construction

Pump Name CDM 120/07

Customer	Date	2024-06-13	Company
Contact	Item no.		Issued by
Phone	Project		Phone
E-mail	Project ID	Proiect redenumit 2024-06-13 13:12:02	E-mail

N°	PART NAME	MATERIAL	DIMENSION	STANDARD	Q.TY	
1	Casing	AISI 304			1	
3	Motor bracket	AISI 304			1	
4	Casing cover	AISI 304			1	
6	Shaft with rotor	AISI 303 (Wet extension)			1	
7	Impeller	AISI 304			1	
11	Mechanical seal [3]	Ceramic/Carbon/NBR			1	
12	Motor frame with stator	-			1	
13	Motor cover	Aluminium			1	
14	Fan	PA			1	
15	Fan cover	AISI 304			1	
16	Terminal board	-			1	
17	Terminal box cover	PA66 glass fibre reinforced class V-0			1	
18	Splash ring	NBR			1	
19	Pump side ball bearing	-			1	
20	Fan side ball bearing	-			1	
21	Adjusting ring	Steel C70			1	
22	Tie rod	Fe 420 Galvanized			4	
23	Capacitor [1]	-			1	
24	Priming plug	AISI 304			1	
25	Drain plug	AISI 304			1	
26	O-ring [2]	NBR			1	
31	Thrust flange	AISI 304			1	
32	Key	AISI 316	4x4x14	UNI 6604	1	
34	Impeller nut	Stainless steel A2-70	M10X1,25	UNI 7474	1	
36	Motor casing	AISI 304			1	
56	Box gasket	NBR			1	
58	Cable entry	-			1	
73	Casing ring	-			1	
75	Washer	AISI 304			1	
76	Washer	AISI 304			1	
77	O-ring [2]	NBR			1	
78	O-ring [2]	NBR			1	
93	Lip seal	NBR			1	
110	Protector [1]	-			1	
200	Screw	120/07	Stainless steel A2-70	M6X12	UNI 5931	8
		70/12, 120/20		M8X14		

- [1] Only for single phase
- [2] FPM for H-HS-HW-HSW
EPDM for E and Special Mechanical Seal
- [3] See **CONSTRUCTION 3**

(3/3) Construction

Pump Name CDM 120/07

Customer	Date 2024-06-13	Company
Contact	Item no.	Issued by
Phone	Project	Phone
E-mail	Project ID Proiect redenumit 2024-06-13 13:12:02	E-mail

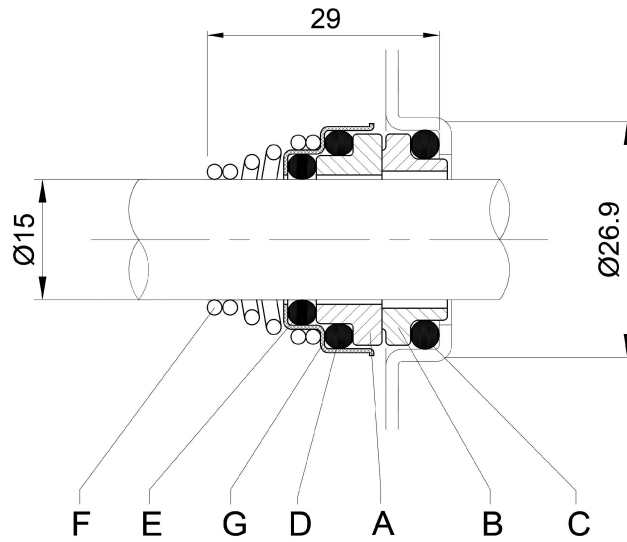

REF	PART NAME	MATERIAL Standard and L version
A	Rotary seal ring	Ceramic
B	Stationary seal ring	Carbon graphite
C	O-Ring	NBR
D	O-Ring	NBR
E	O-Ring	NBR
F	Self-driving spring	AISI 316
G	Frame	AISI 304