

Technical Data

Pump Name

CD 200/25

Customer	Date	2024-06-13	Company
Contact	Item no.		Issued by
Phone	Project		Phone
E-mail	Project ID	Proiect redenumit 2024-06-13 13:12:02	E-mail

Requested data

1	Pump type	CENTRIFUGAL PUMPS	Fluid	Water
2	Number of pumps / Reserve	1 / 0	Liquid temperature	°C
3	Flow	m³/h	Kin. viscosity	mm²/s
4	Head	m	Vapour pressure	bar
5	Geodetic head	m	PH value	
6	Inlet pressure (pin)	bar	Density	kg/m³
7	Available system NPSH		Solids	Weight %
8	Ambient temperature	°C		

Pump

9	Pump Name	CD 200/25	Frequency	Hz	50	
10	Design	CENTRIFUGAL PUMPS	Installation type		STANDARD	
11	Manufacturer	EBARA	Impeller Diameter	Max.	mm	
12	Speed	rpm		2800	Designed	mm
13	No. of Stage	1		Min.	mm	176
14	Connection	Suction side	UNI ISO 228-1	Flow	Operating	m³/h
15	Connection	Discharge side	UNI ISO 228-1		Max-	m³/h
16	Max Working Pressure	bar	8		Min-	m³/h
17	Shut-off head	bar	3.86	Head	Operating	m
18	Total weight	kg	See the table of "Dimensions".		- (Qmax.)	m
19	Shaft power	kW			- (Qmin.)	m
20				Max. Shaft Power at max. impeller	kW	2.19
21	Required pump NPSH	m		Efficiency	%	

Materials

22	Impeller	AISI 304		
23	Casing	AISI 304		
24	Shaft	AISI 303 (Wet extension)		
25				
26				
27				

Motor

28	Manufacturer	EPE Standard	Insulation class	F	
29	Type	TEFC_CD 200/25_230_Three Phase	Phases	3~	
30	Specific design	IE3 / 50 Hz / Pole pairs 1	Frame size		
31	Rated power	kW	1.85	Weight	kg
32	Number of poles	2	Electric voltage	V	230
33	Speed	rpm	2800	Electric current	A
34	Degree of protection	IP 55			
35					

Remarks

Performance Curve

Pump Name

CD 200/25

Customer	Date	2024-06-13	Company
Contact	Item no.		Issued by
Phone	Project		Phone
E-mail	Project ID	Proiect redenumit 2024-06-13 13:12:02	E-mail

Requested data

1	Flow	m³/h	
2	Head	m	
3	Geodetic head	m	

Pump

Operating flow	m³/h		Frequency	Hz	50
Operating head	m		Number of poles		2
Impeller diameter designed	mm	176	Speed	rpm	2800

Test standard: ISO 9906:2012 - Grade3B

Water; 20°C; 998.3kg/m³; 1mm²/s

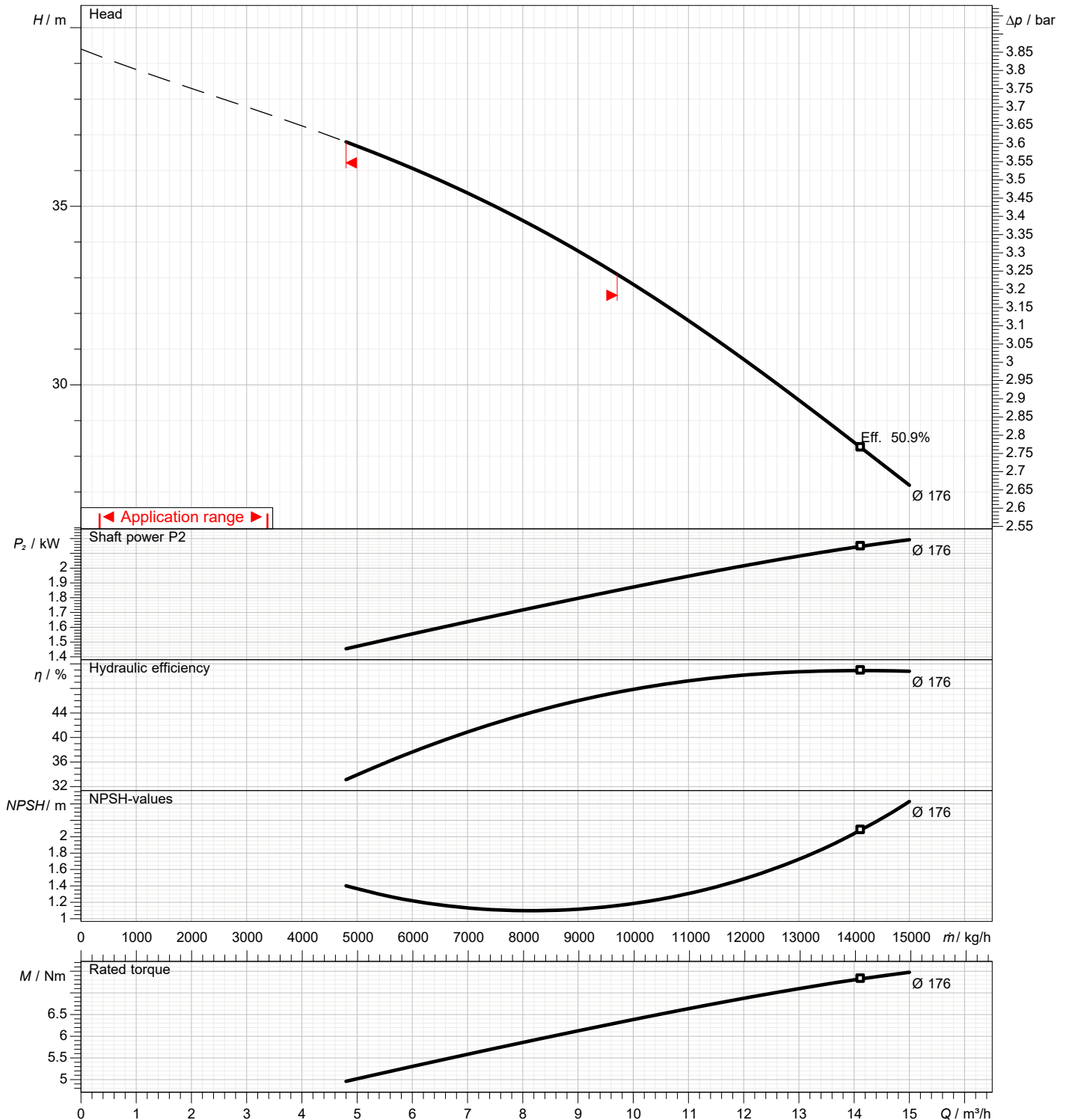

Dimensions

Pump Name CD 200/25

Customer	Date 2024-06-13	Company
Contact	Item no.	Issued by
Phone	Project	Phone
E-mail	Project ID Proiect redenumit 2024-06-13 13:12:02	E-mail

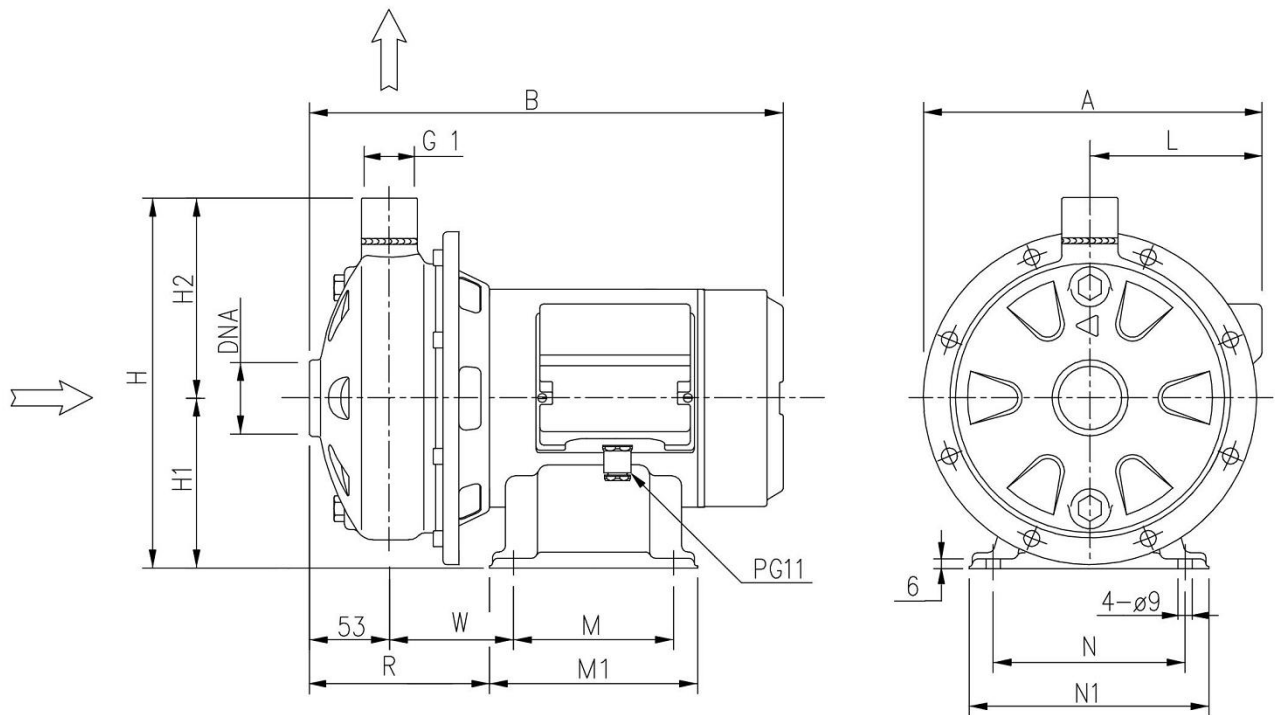

Dimensions in		mm						
1	A	232						
2	B	376						
3	DNA	G 1" 1/2						
4	H	250						
5	H1	118						
6	H2	132						
7	L	116						
8	M	120						
9	M1	150						
10	N	140						
11	N1	170						
12	R	138						
13	W	100						
14	Weight P&M	18.3kg						
15								

(1/3) Construction

Pump Name CD 200/25

Customer	Date 2024-06-13	Company
Contact	Item no.	Issued by
Phone	Project	Phone
E-mail	Project ID Proiect redenumit 2024-06-13 13:12:02	E-mail

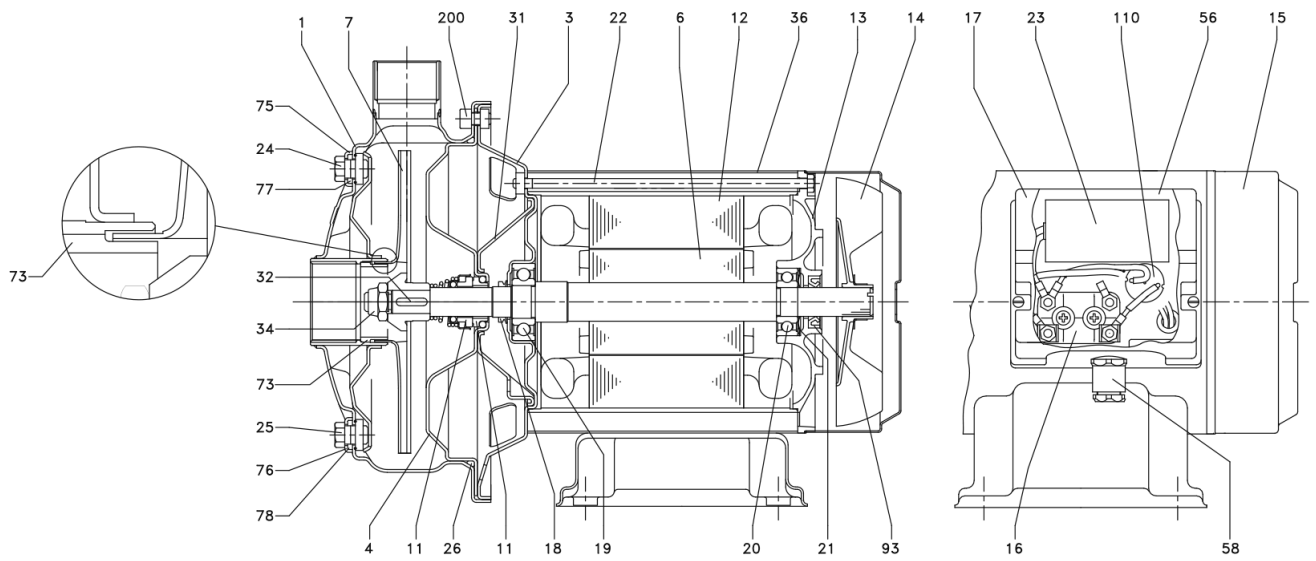

(2/3)

Construction

Pump Name CD 200/25

Customer	Date	2024-06-13	Company
Contact	Item no.		Issued by
Phone	Project		Phone
E-mail	Project ID	Proiect redenumit 2024-06-13 13:12:02	E-mail

N°	PART NAME	MATERIAL	DIMENSION	STANDARD	Q.TY
1	Casing	AISI 304			1
3	Motor bracket	AISI 304			1
4	Casing cover	AISI 304			1
6	Shaft with rotor	AISI 303 (Wet extension)			1
7	Impeller	AISI 304			1
11	Mechanical seal [3]	Ceramic/Carbon/NBR			1
12	Motor frame with stator	-			1
13	Motor cover	Aluminium			1
14	Fan	PA			1
15	Fan cover	AISI 304			1
16	Terminal board	-			1
17	Terminal box cover	PA66 glass fibre reinforced class V-0			1
18	Splash ring	NBR			1
19	Pump side ball bearing	-			1
20	Fan side ball bearing	-			1
21	Adjusting ring	Steel C70			1
22	Tie rod	Fe 420 Galvanized			4
23	Capacitor [1]	-			1
24	Priming plug	AISI 304			1
25	Drain plug	AISI 304			1
26	O-ring [2]	NBR			1
31	Thrust flange	AISI 304			1
32	Key	AISI 316	4x4x14	UNI 6604	1
34	Impeller nut	Stainless steel A2-70	M10X1,25	UNI 7474	1
36	Motor casing	AISI 304			1
56	Box gasket	NBR			1
58	Cable entry	-			1
73	Double ring	AISI 304			1
75	Washer	AISI 304			1
76	Washer	AISI 304			1
77	O-ring [2]	NBR			1
78	O-ring [2]	NBR			1
93	Lip seal	NBR			1
110	Protector [1]	-			1
200	Screw	120/12,200/12,200/20	M6X12	UNI 5931	8
		200/25	M8X14		

[1] Only for single phase

[2] FPM for H-HS-HW-HSW
EPDM for E and Special Mechanical Seal

[3] See **CONSTRUCTION 3**

(3/3)

Construction

Pump Name CD 200/25

Customer	Date 2024-06-13	Company
Contact	Item no.	Issued by
Phone	Project	Phone
E-mail	Project ID Proiect redenumit 2024-06-13 13:12:02	E-mail

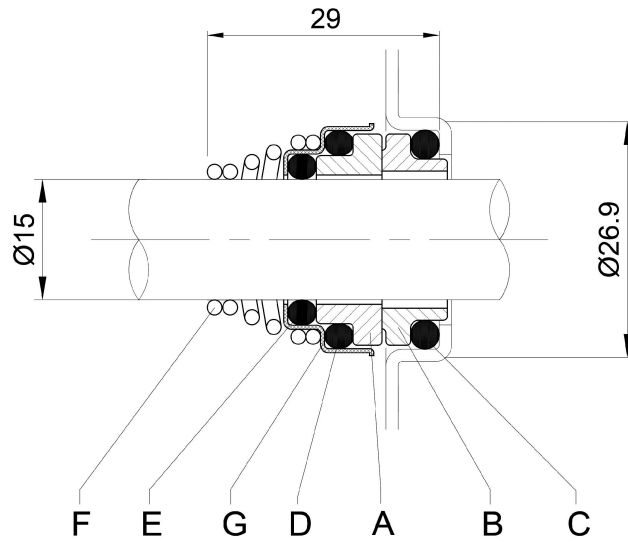

REF	PART NAME	MATERIAL Standard and L version
A	Rotary seal ring	Ceramic
B	Stationary seal ring	Carbon graphite
C	O-Ring	NBR
D	O-Ring	NBR
E	O-Ring	NBR
F	Self-driving spring	AISI 316
G	Frame	AISI 304