

# Technical Data

Pump Name

CMA 1.00

Customer	Date	2024-06-13	Company
Contact	Item no.		Issued by
Phone	Project		Phone
E-mail	Project ID	Proiect redenumit 2024-06-13 13:12:02	E-mail

## Requested data

1	Pump type	CENTRIFUGAL PUMPS	Fluid	Water
2	Number of pumps / Reserve	1 / 0	Liquid temperature	°C 20
3	Flow m³/h		Kin. viscosity	mm²/s 1.005
4	Head m		Vapour pressure	bar 0.0234
5	Geodetic head m		PH value	
6	Inlet pressure (pin) bar	0	Density	kg/m³ 998.3
7	Available system NPSH		Solids	Weight % 0
8	Ambient temperature °C	20		

## Pump

9	Pump Name	CMA 1.00	Frequency	Hz 50
10	Design	CENTRIFUGAL PUMPS	Installation type	STANDARD
11	Manufacturer	EBARA	Impeller Diameter	Max. mm 160
12	Speed rpm	2800		Designed mm 160
13	No. of Stage	1		Min. mm 160
14	Connection Suction side	UNI ISO 228	Flow	Operating m³/h
15	Connection Discharge side	UNI ISO 228		Max- m³/h 5.7
16	Max Working Pressure bar	6		Min- m³/h 1.2
17	Shut-off head bar	3.29	Head	Operating m
18	Total weight kg	See the table of "Dimensions".		- (Qmax.) m 23.5
19	Shaft power kW			- (Qmin.) m 33.0
20			Max. Shaft Power at max. impeller	kW 0.77
21	Required pump NPSH m		Efficiency	%

## Materials

22	Impeller	PPE+PS glass fibre reinforced	
23	Casing	Cast iron	
24	Shaft	AISI 303 (wet extension)	
25			
26			
27			

## Motor

28	Manufacturer	EPE Standard	Insulation class	F
29	Type	TEFC_CMA 1.00 M_230_Single Phase	Phases	1~
30	Specific design	IE2 / 50 Hz / Pole pairs 1	Frame size	
31	Rated power kW	0.75	Weight	kg
32	Number of poles	2	Electric voltage	V 230
33	Speed rpm	2800	Electric current	A 5.4
34	Degree of protection	IP 44		
35				

## Remarks

# Performance Curve

Pump Name

CMA 1.00

Customer	Date	2024-06-13	Company
Contact	Item no.		Issued by
Phone	Project		Phone
E-mail	Project ID	Proiect redenumit 2024-06-13 13:12:02	E-mail

### Requested data

1	Flow	m³/h	
2	Head	m	
3	Geodetic head	m	

### Pump

Operating flow	m³/h		Frequency	Hz	50
Operating head	m		Number of poles		2
Impeller diameter designed	mm	160	Speed	rpm	2800

Test standard: ISO 9906:2012 - Grade3B

Water; 20°C; 998.3kg/m³; 1mm²/s

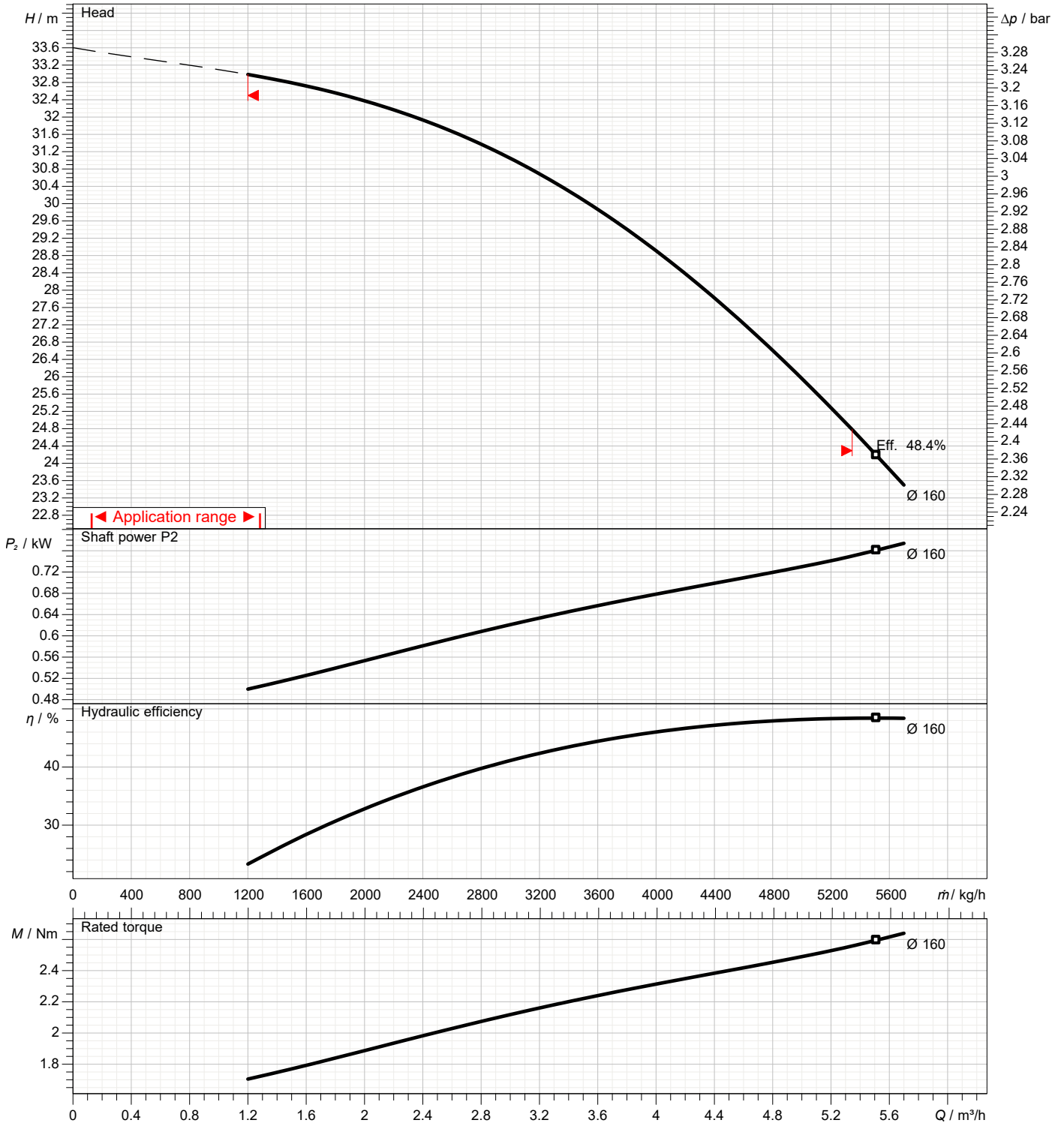

# Dimensions

Pump Name CMA 1.00

Customer	Date 2024-06-13	Company
Contact	Item no.	Issued by
Phone	Project	Phone
E-mail	Project ID Proiect redenumit 2024-06-13 13:12:02	E-mail

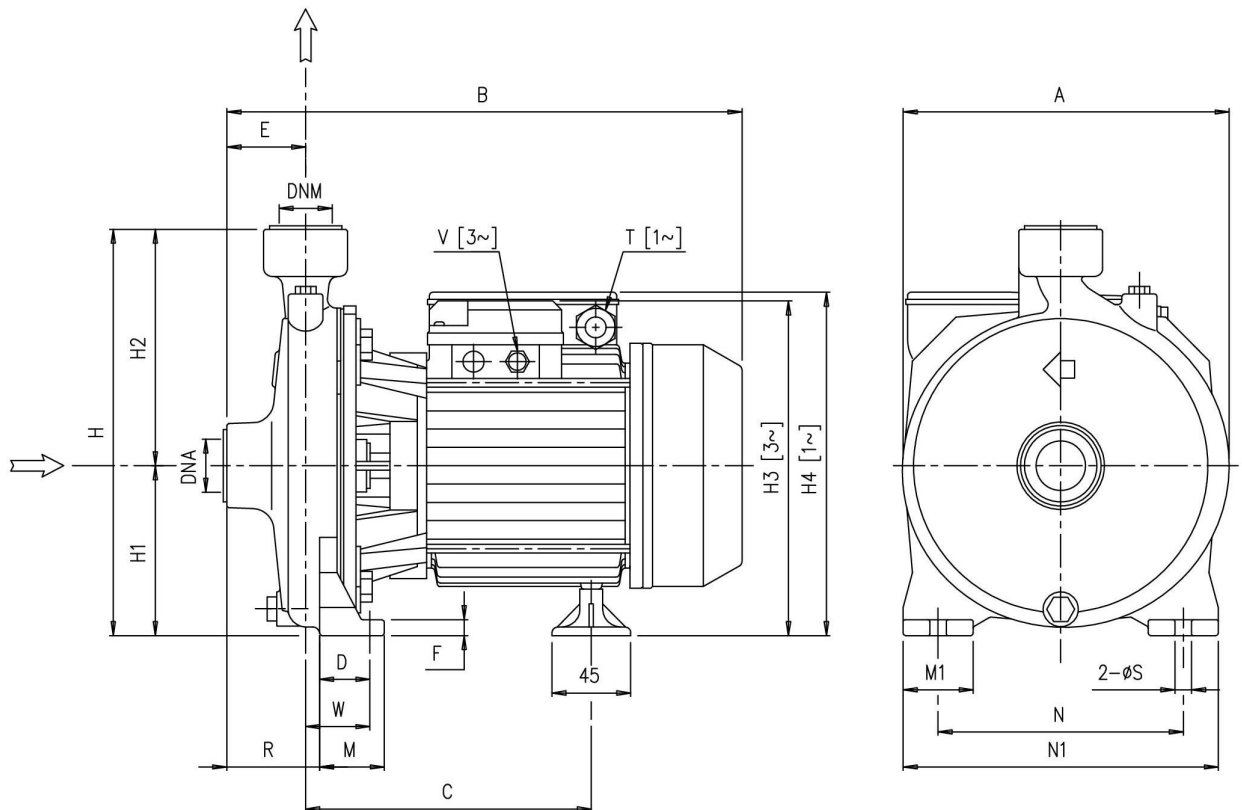

[1~] Single phase  
[3~] Three phase

Dimensions in		mm						
1	A	185	N1	180				
2	B	300.3	R	45				
3	C	171.8	S	9.5				
4	D	36.8	T	PG 11				
5	DNA	G 1	W	36.8				
6	DNM	G 1	Weight P&M	11,5 kg				
7	E	45						
8	F	9						
9	H	232						
10	H1	97						
11	H2	135						
12	H4	198						
13	M	45						
14	M1	40						
15	N	140						

(1/3)

# Construction

Pump Name CMA 1.00

Customer	Date 2024-06-13	Company
Contact	Item no.	Issued by
Phone	Project	Phone
E-mail	Project ID Proiect redenumit 2024-06-13 13:12:02	E-mail

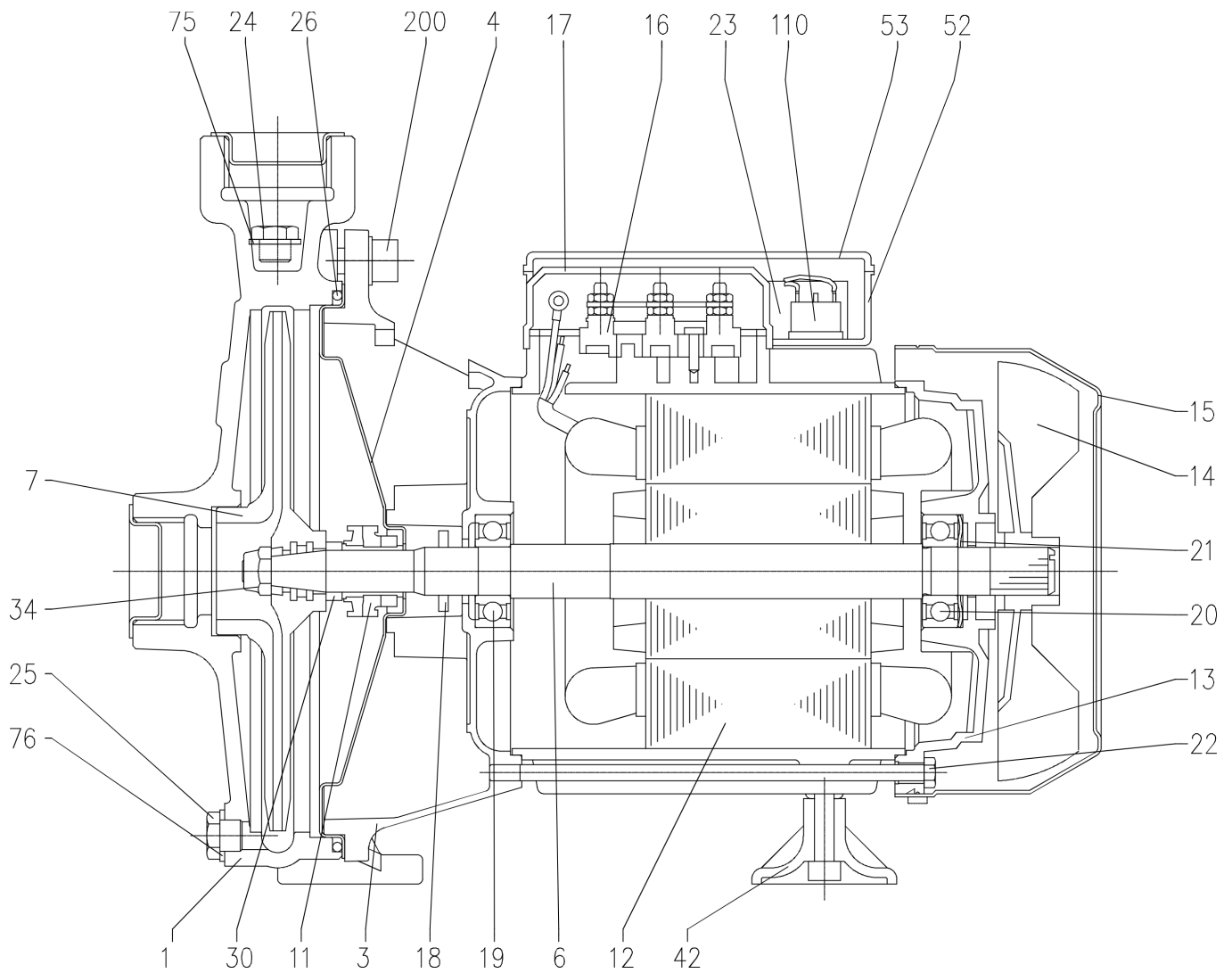

(2/3)

# Construction

Pump Name CMA 1.00

Customer	Date	2024-06-13	Company
Contact	Item no.		Issued by
Phone	Project		Phone
E-mail	Project ID	Proiect redenumit 2024-06-13 13:12:02	E-mail

N°	PART NAME		MATERIAL	DIMENSIONS	STANDARD	Q.TY
1	Casing		Cast iron			1
3	Motor bracket		Aluminium			1
4	Casing cover		AISI 304			1
6	Shaft with rotor		[1]			1
7	Impeller		[2]			1
11	Mechanical seal [7]		Carbon/Ceramic/NBR			1
12	Motor frame with stator		-			1
13	Motor cover		Aluminium			1
14	Fan		PA			1
15	Fan cover		Fe P04 Galvanized			1
16	Terminal box		-			1
17	Terminal box cover [3]		Aluminium			1
18	Splash ring	CMA 0.50 other models	NBR	D25x11.5x2.5 D25x14.5x2.5	EBARA DRAWING	1
19	Pump side ball bearing		-			1
20	Fan side ball bearing		-			1
21	Adjusting ring		Steel C70			1
22	Tie rod		Fe 42 Galvanized			4
23	Capacitor [4]		-			1
24	Priming plug		Brass	G 1/8"	UNI 338	1
25	Drain plug		Brass	G 1/8"	UNI 338	1
26	O-ring		NBR			1
30	Mechanical seal spacer [5]		Brass			1
34	Impeller nut [6]		AISI 304	M8x1	UNI7474	1
42	Foot		PP			1
52	Capacitor box [4]		ABS class V-0			1
53	Capacitor box cover [4]		ABS class V-0			1
75	Washer		Aluminium	10x16x1.5		1
76	Washer		Aluminium	10x16x1.5		1
110	Protector [4]		-			-
200	Screw	CMA 0.50 CMA 0.75; 1.00 CMC 0.75; 1.00 CMB 0.75; 1.00	Zn Steel Cl. 8.8	M6x16 M8x18 M8x22	ISO 898-1	4

- [1] Material: AISI 416 (integral) for CMA 0.50  
AISI 303 (wet extension) for other model;
- [2] Material: PPE+PS glass fibre reinforced for version CMA  
Cast iron for version CMB, CMC;
- [3] Only for three phase
- [4] Only for single phase
- [5] Only for version: CMA 0.50, CMB 0.75-1.00, CMC 0.75-1.00
- [6] Except for CMA 0.50
- [7] See **CONSTRUCTION 3**

# (3/3) Construction

Pump Name CMA 1.00

Customer	Date 2024-06-13	Company
Contact	Item no.	Issued by
Phone	Project	Phone
E-mail	Project ID Proiect redenumit 2024-06-13 13:12:02	E-mail

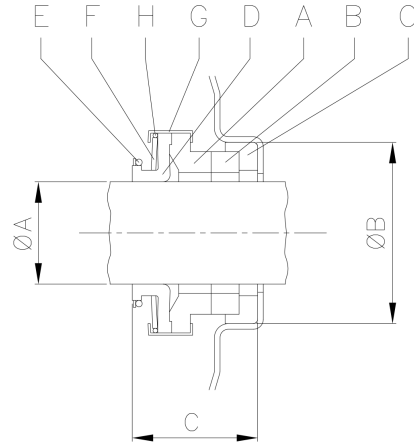

Pump type		Dimensions mm		
Single phase	Three phase	Ø A	Ø B	C
CMA 0.75 M	CMA 0.75 T	13	26	18.3
CMA 1.00 M	CMA 1.00 T	13	26	18.3
CMB 0.75 M	CMB 0.75 T	13	26	18.3
CMB 1.00 M	CMB 1.00 T	13	26	18.3
CMC 0.75 M	CMC 0.75 T	13	26	18.3
CMC 1.00 M	CMC 1.00 T	13	26	18.3

REF	PART NAME	MATERIAL product standard
A	Rotary seal ring	carbon graphite
B	Stationary seal ring	ceramic
C	Gasket	NBR
D	Bellows	NBR
E	Ring	AISI 304
F	Self driving spring	AISI 304
G	Frame	AISI 304
H	Retainer ring	AISI 304