

Technical Data

Pump Name

CMD 306 T IE3

Customer	Date	2024-07-01	Company
Contact	Item no.		Issued by
Phone	Project		Phone
E-mail	Project ID	Proiect redenumit 2024-07-01 15:55:48	E-mail

Requested data

1	Pump type	CENTRIFUGAL PUMPS	Fluid	Water
2	Number of pumps / Reserve	1 / 0	Liquid temperature	°C
3	Flow	m³/h	Kin. viscosity	mm²/s
4	Head	m	Vapour pressure	bar
5	Geodetic head	m	PH value	
6	Inlet pressure (pin)	bar	Density	kg/m³
7	Available system NPSH		Solids	Weight %
8	Ambient temperature	°C		

Pump

9	Pump Name	CMD 306 T IE3	Frequency	Hz	60	
10	Design	CENTRIFUGAL PUMPS	Installation type		STANDARD	
11	Manufacturer	EBARA	Impeller Diameter	Max.	mm	
12	Speed	rpm		3400	Designed	mm
13	No. of Stage	1		Min.	mm	101
14	Connection	Suction side	UNI ISO 228	Flow	Operating	m³/h
15	Connection	Discharge side	UNI ISO 228		Max-	m³/h
16	Max Working Pressure	bar	6		Min-	m³/h
17	Shut-off head	bar	1.43	Head	Operating	m
18	Total weight	kg	See the table of "Dimensions".		- (Qmax.)	m
19	Shaft power	kW			- (Qmin.)	m
20				Max. Shaft Power at max. impeller	kW	
21	Required pump NPSH	m		Efficiency	%	

Materials

22	Impeller	Cast iron		
23	Casing	Cast iron		
24	Shaft	AISI 303 (wet extension)		
25				
26				
27				

Motor

28	Manufacturer	EPE Standard	Insulation class	F	
29	Type	TEFC_CMD 306 T_460_Three Phase	Phases	3~	
30	Specific design	IE3 / 60 Hz / Pole pairs 1	Frame size		
31	Rated power	kW	2.2	Weight	kg
32	Number of poles	2	Electric voltage	V	460
33	Speed	rpm	3400	Electric current	A
34	Degree of protection	IP 44			
35					

Remarks

Performance Curve

Pump Name

CMD 306 T IE3

Customer	Date	2024-07-01	Company
Contact	Item no.		Issued by
Phone	Project		Phone
E-mail	Project ID	Proiect redenumit 2024-07-01 15:55:48	E-mail

Requested data

1	Flow	m³/h	
2	Head	m	
3	Geodetic head	m	

Pump

Operating flow	m³/h		Frequency	Hz	60
Operating head	m		Number of poles		2
Impeller diameter designed	mm	101	Speed	rpm	3400

Test standard: ISO 9906:2012 - Grade3B

Water; 20°C; 998.3kg/m³; 1mm²/s

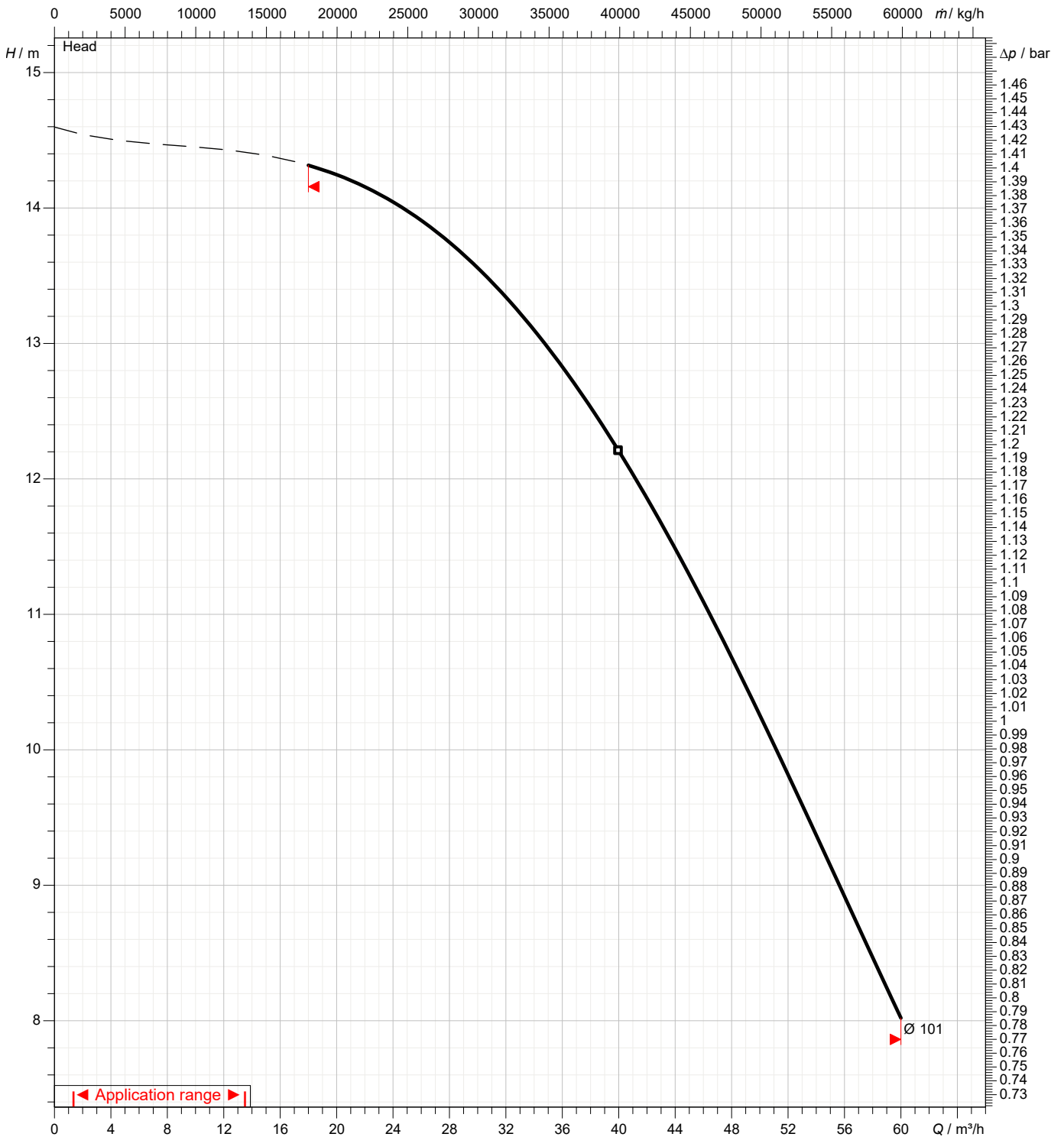

Dimensions

Pump Name **CMD 306 T IE3**

Customer	Date 2024-07-01	Company
Contact	Item no.	Issued by
Phone	Project	Phone
E-mail	Project ID Proiect redenumit 2024-07-01 15:55:48	E-mail

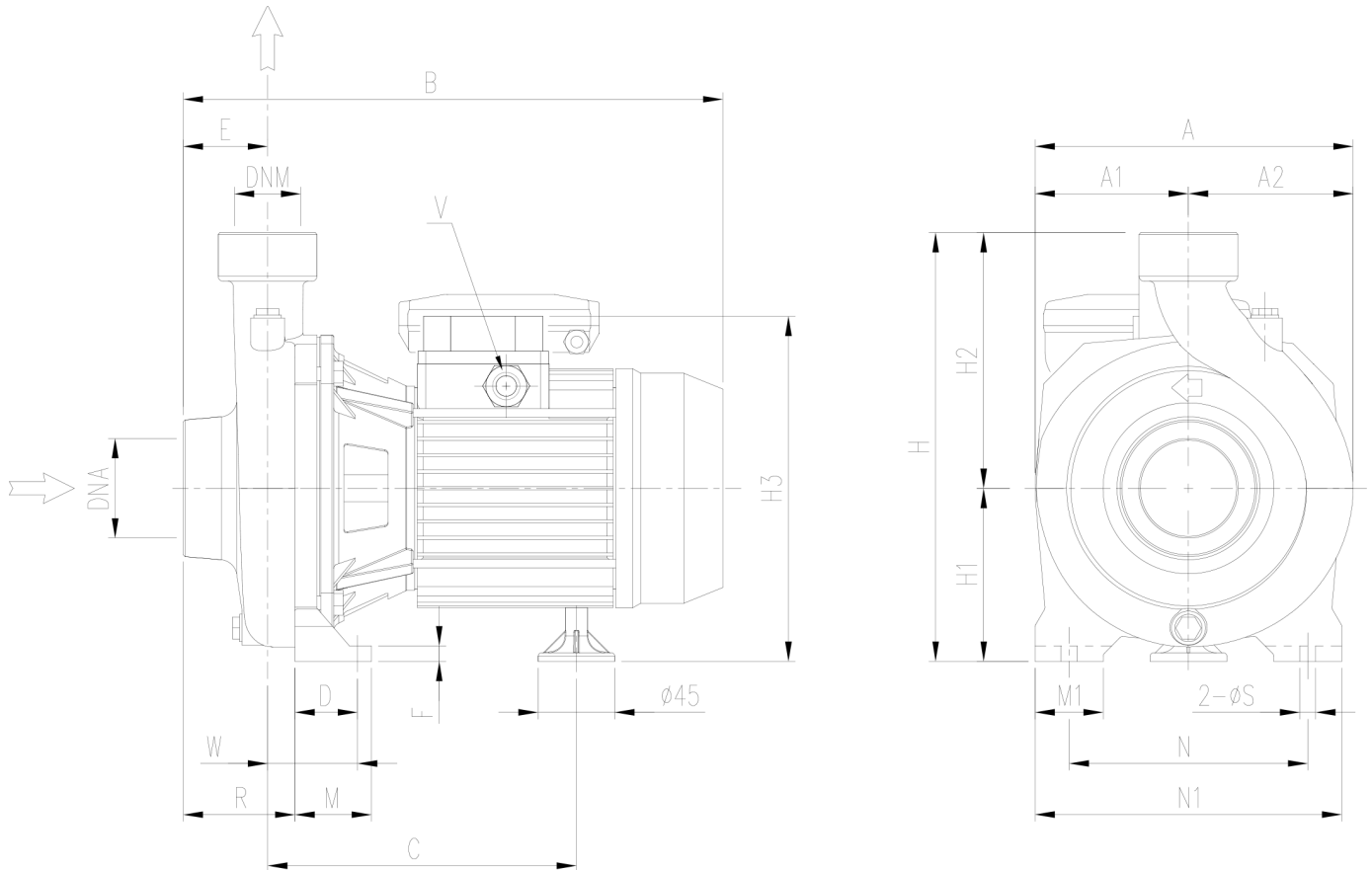

Dimensions in		mm		
1	A	211	M1	40
2	A1	97	N	160
3	A2	114	N1	200
4	B	409	R	100.5
5	C	221	S	9.5
6	D	37	V	M20x1,5
7	DNA	G 2 1/2	W	70
8	DNM	G 2 1/2	Weight P&M	24 kg
9	E	68		
10	F	12		
11	H	271.5		
12	H1	111.5		
13	H2	160		
14	H3	230.5		
15	M	45		

(1/3)

Construction

Pump Name CMD 306 T IE3

Customer	Date 2024-07-01	Company
Contact	Item no.	Issued by
Phone	Project	Phone
E-mail	Project ID Proiect redenumit 2024-07-01 15:55:48	E-mail

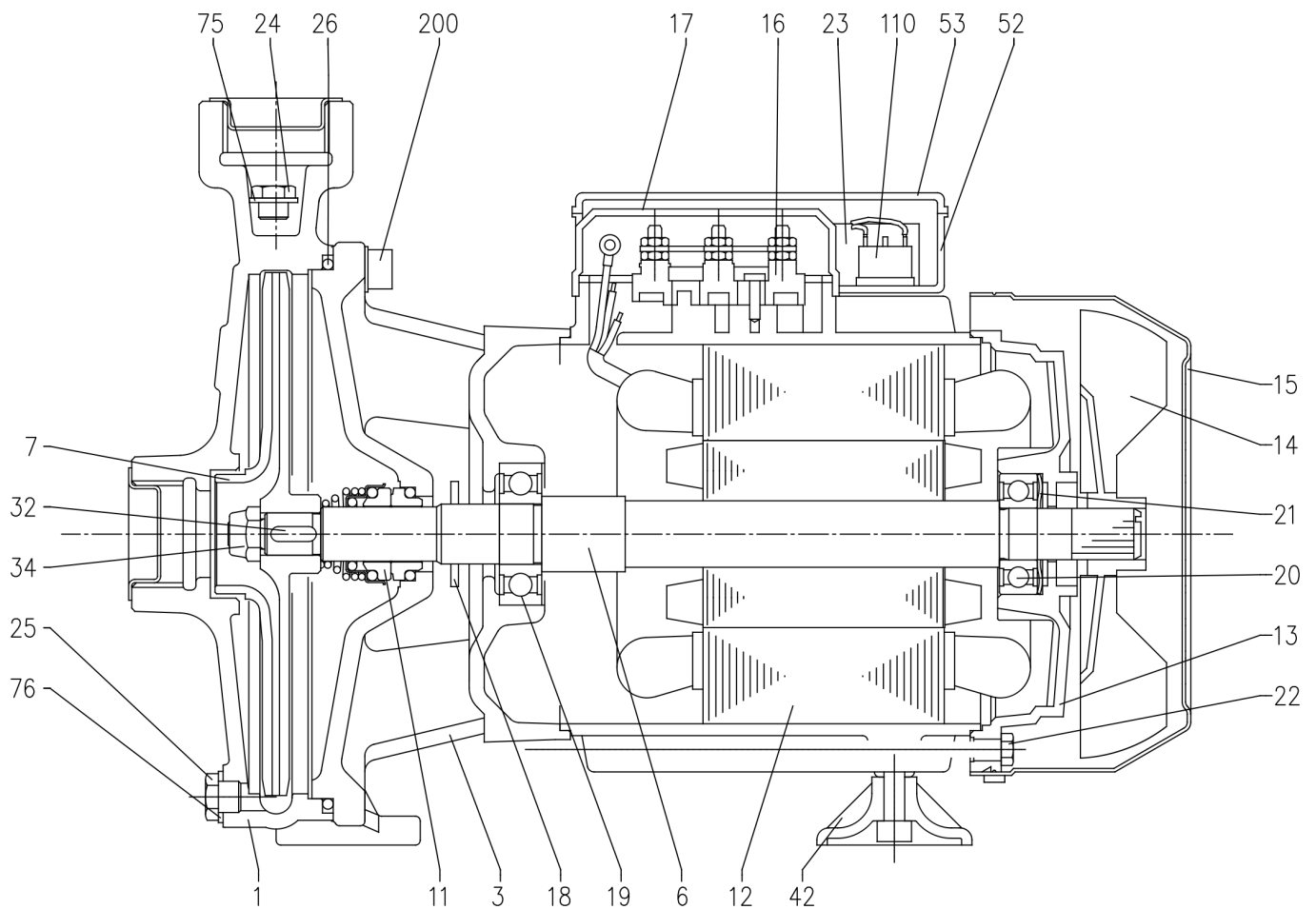

(2/3)

Construction

Pump Name CMD 306 T IE3

Customer	Date	2024-07-01	Company
Contact	Item no.		Issued by
Phone	Project		Phone
E-mail	Project ID	Project redenumit 2024-07-01 15:55:48	E-mail

N°	PART NAME	MATERIAL	Q.TY
1	Casing	Cast iron	1
3	Motor bracket	Cast iron	1
6	Shaft with rotor [1]	-	1
7	Impeller [2]	-	1
11	Mechanical seal [3]	Carbon/Ceramic/NBR	1
12	Motor frame with stator	-	1
13	Motor cover	Aluminium	1
14	Fan	PA6	1
15	Fan cover	Fe P04 Zincate	1
16	Terminal board	-	1
17	Terminal box cover [4]	Aluminium	1
18	Splash ring	NBR	1
19	Pump side ball bearing	-	1
20	Fan side ball bearing	-	1
21	Adjusting ring	Steel C70	1
22	Tie rod	Fe 42 Zincate	4
23	Capacitor [5]	-	1
24	Priming plug	Brass	1
25	Drain plug	Brass	1
26	O-ring	NBR	1
32	Key	AISI 316	1
34	Impeller nut	AISI 304	1
42	Foot	PP	1
52	Capacitor box [5]	ABS class V-0	1
53	Capacitor box cover [5]	ABS class V-0	1
75	Washer	Aluminium	1
76	Washer	Aluminium	1
110	Protector [5]	-	1
200	Screw	Zn Steel Cl. 8.8 ISO 898-1	4

[1] Material: AISI 303 (wet extension) for version CMA, CMB 156-206-306, CMD 206-306

AISI 304 (wet extension) for version CMB 406-556, CMD 406

[2] Material: Brass for version: CMA, CMB 206-306-406-556

Cast iron for version: CMB 156, CMD

[3] See CONSTRUCTION 3

[4] Only for three phase

[5] Only for single phase

(3/3)

Construction

Pump Name CMD 306 T IE3

Customer	Date 2024-07-01	Company
Contact	Item no.	Issued by
Phone	Project	Phone
E-mail	Project ID Proiect redenumit 2024-07-01 15:55:48	E-mail

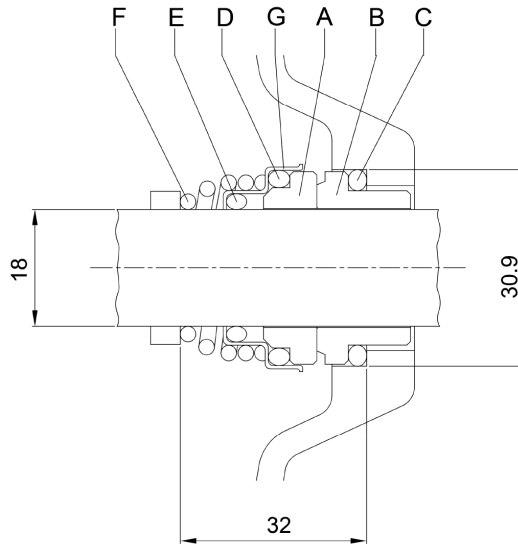

REF	PART NAME	MATERIAL Standard version
A	Rotary seal ring	Ceramic
B	Stationary seal ring	Carbon Graphite
C	O Ring	NBR
D	O Ring	NBR
E	O Ring	NBR
F	Self driving spring	AISI 316
G	Frame	AISI 304