

Technical Data

Pump Name

CVM AM/10

Customer	Date	2024-06-13	Company
Contact	Item no.		Issued by
Phone	Project		Phone
E-mail	Project ID	Proiect redenumit 2024-06-13 13:12:02	E-mail

Requested data

1	Pump type	MULTISTAGE CENTRIFUGAL PUMPS	Fluid	Water
2	Number of pumps / Reserve	1 / 0	Liquid temperature	°C 20
3	Flow m³/h		Kin. viscosity	mm²/s 1.005
4	Head m		Vapour pressure	bar 0.0234
5	Geodetic head m		PH value	
6	Inlet pressure (pin) bar	0	Density	kg/m³ 998.3
7	Available system NPSH		Solids	Weight % 0
8	Ambient temperature °C	20		

Pump

9	Pump Name	CVM AM/10	Frequency	Hz 50
10	Design	MULTISTAGE CENTRIFUGAL PUMPS	Installation type	STANDARD
11	Manufacturer	EBARA	Impeller Diameter	Max. mm 102
12	Speed rpm	2800		Designed mm 102
13	No. of Stage	5		Min. mm 102
14	Connection Suction side	UNI ISO 228	Flow	Operating m³/h
15	Connection Discharge side	UNI ISO 228		Max- m³/h 4.8
16	Max Working Pressure bar	11		Min- m³/h 1.2
17	Shut-off head bar	6.12	Head	Operating m
18	Total weight kg	See the table of "Dimensions".		- (Qmax.) m 19.5
19	Shaft power kW			- (Qmin.) m 57.6
20			Max. Shaft Power at max. impeller	kW 0.82
21	Required pump NPSH m		Efficiency	%

Materials

22	Impeller	PPE+PS Glass fibre reinforced	
23	Casing	Cast iron	
24	Shaft	AISI 416	
25			
26			
27			

Motor

28	Manufacturer	EPE Standard	Insulation class	F
29	Type	TEFC_CVM AM/10_230_Single Phase	Phases	1~
30	Specific design	IE2 / 50 Hz / Pole pairs 1	Frame size	71
31	Rated power kW	0.9	Weight	kg
32	Number of poles	2	Electric voltage	V 230
33	Speed rpm	2850	Electric current	A 5.4
34	Degree of protection	IP 44		
35				

Remarks

Performance Curve

Pump Name

CVM AM/10

Customer	Date	2024-06-13	Company
Contact	Item no.		Issued by
Phone	Project		Phone
E-mail	Project ID	Proiect redenumit 2024-06-13 13:12:02	E-mail

Requested data

1	Flow	m³/h	
2	Head	m	
3	Geodetic head	m	

Pump

Operating flow	m³/h		Frequency	Hz	50
Operating head	m		Number of poles		2
Impeller diameter designed	mm	102	Speed	rpm	2800

Test standard: ISO 9906:2012 - Grade3B

Water; 20°C; 998.3kg/m³; 1mm²/s

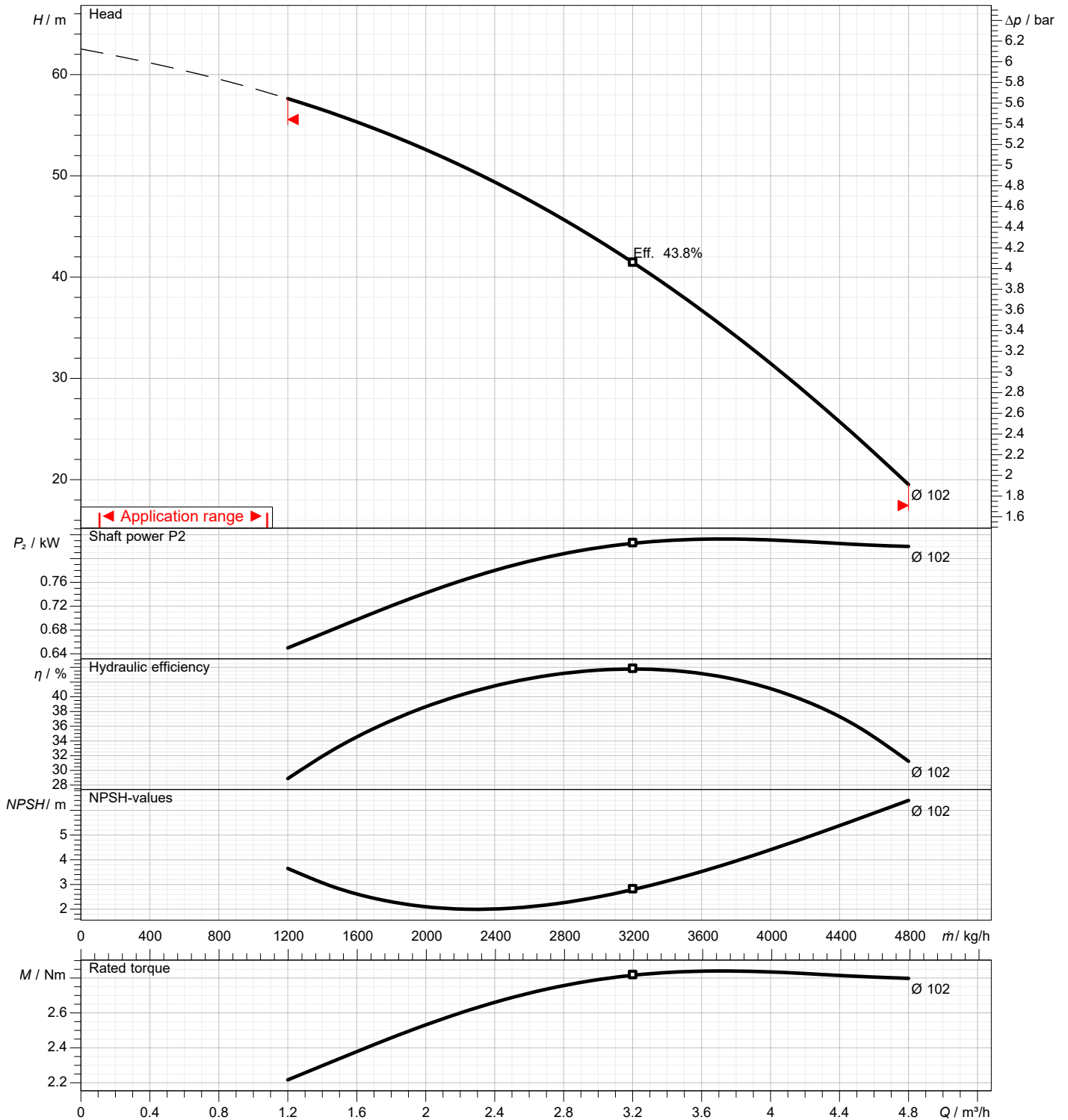

Dimensions

Pump name CVM AM/10

Customer	Date 2024-06-13	Company
Contact	Item no.	Issued by
Phone	Project	Phone
E-mail	Project ID Proiect redenumit 2024-06-13 13:12:02	E-mail

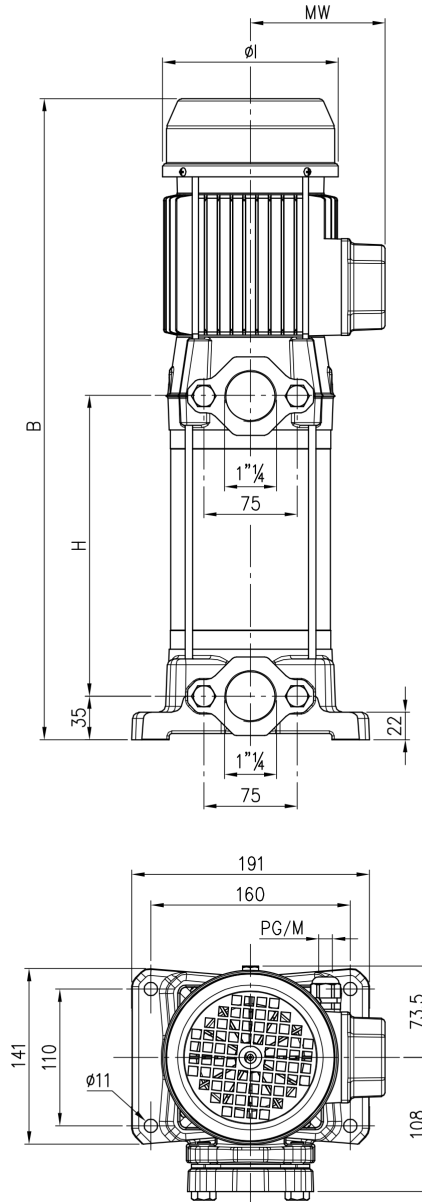

Dimensions in		mm						
1	B	464						
2	H	190						
3	I	141						
4	MW	110.5						
5	PG	11						
6	Weight P&M	17 kg						
7								
8								
9								
10								
11								
12								
13								
14								
15								

(1/4)

Construction

Pump name CVM AM/10

Customer	Date 2024-06-13	Company
Contact	Item no.	Issued by
Phone	Project	Phone
E-mail	Project ID Proiect redenumit 2024-06-13 13:12:02	E-mail

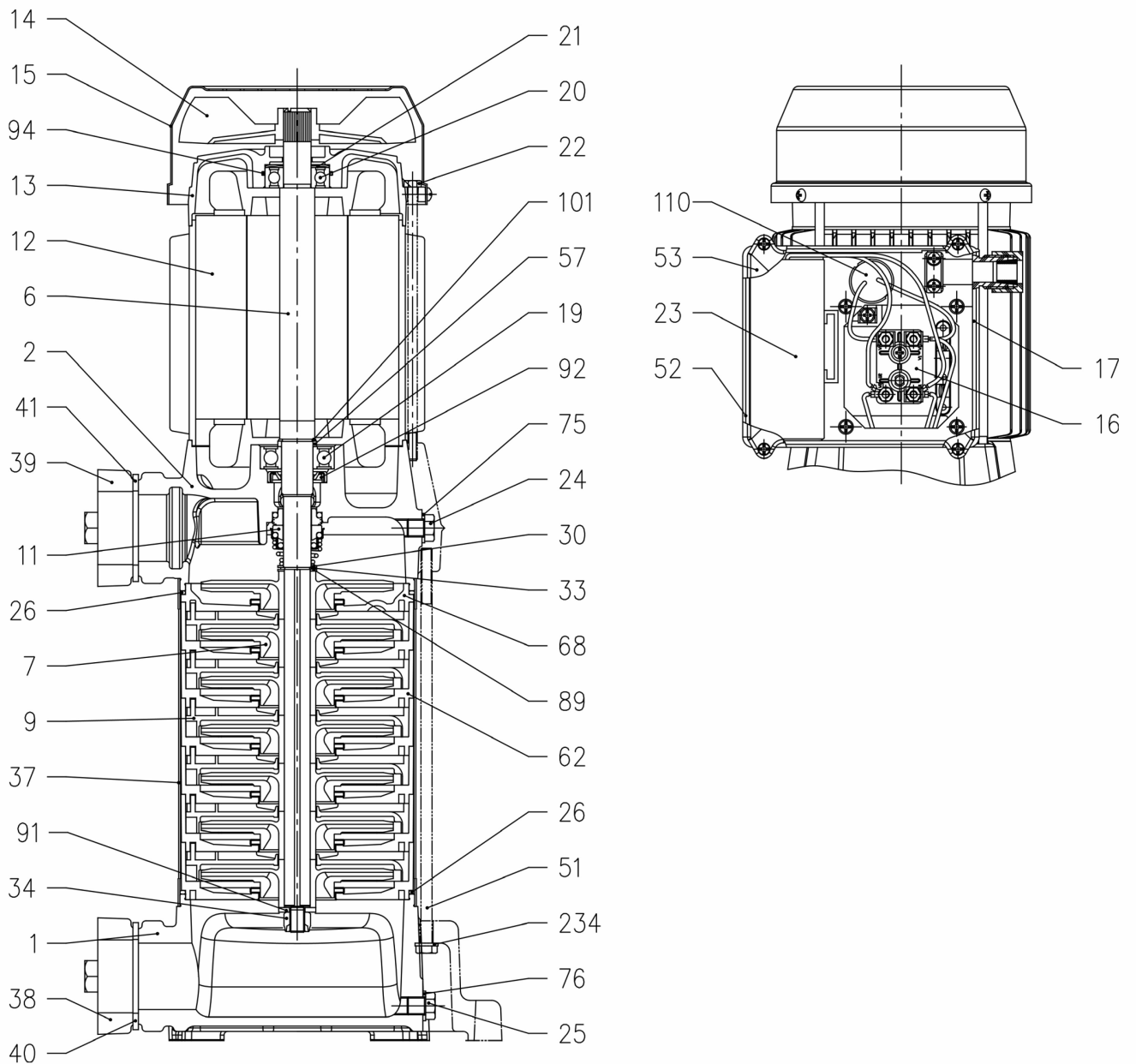

(2/4)**Construction****Pump name CVM AM/10**

Customer	Date 2024-06-13	Company
Contact	Item no.	Issued by
Phone	Project	Phone
E-mail	Project ID Proiect redenumit 2024-06-13 13:12:02	E-mail

N°	PART NAME	MATERIAL	DIMENSIONS	STANDARD	Q.TY
1	Suction casing	Cast iron EN-GJL-200-EN 1561	-	-	1
2	Delivery casing	Cast iron EN-GJL-200-EN 1561	-	-	1
6	Shaft with rotor	EN 1.4005 (AISI 416)	-	-	1
7	Impeller	PPE+PS Glass fibre reinforced	-	-	[1]
9	Diffuser	PPE+PS Glass fibre reinforced	-	-	[1]
11	Mechanical seal [2]	Carbon / Ceramic / NBR	-	-	1
12	Motor frame with stator	-	-	-	1
13	Motor cover + Spacer [8]	Aluminium	-	-	1
14	Fan	PA	-	-	1
15	Fan cover	Galvanized Fe P04	-	-	1
16	Terminal board	-	-	-	1
17	Terminal box cover [3]	Aluminium	-	-	1
19	Pump side ball bearing	-	[4]	-	1
20	Fan side ball bearing	-	[4]	-	1
21	Adjusting ring	Steel C70	-	-	1
22	Motor tie rod	Galvanized Fe 42	M5xL	EBARA DRAWING	4
23	Capacitor [5]	-	-	-	1
24	Priming plug	OT 58 UNI 5705	G 1/8"	UNI ISO 228	1
25	Drain plug	OT 58 UNI 5705	G 1/8"	UNI ISO 228	1
26	O-ring	NBR	120x3	-	2
30	Washer	EN 1.4301 (AISI 304)	12x22x1 - [UP to 0,6kW] 15x22x1 - [0,75 kW and above]	EBARA DRAWING	1
33	Seeger ring	EN 1.4021 (AISI 420) EN 1.4301 (AISI 304)	12 14	UNI 7435 JIS B2804-1978	1
34	Impeller nut	EN 1.4301 (AISI 304)	M8x1 - [UP to 0,6kW] M10x1,25 - [0,75 kW and above]	UNI 7474	1
37	External pump casing	EN 1.4301 (AISI 304)	-	-	1
38	Counter flange	Cast iron EN-GJL-200-EN 1561	1"¼	EBARA DRAWING	1
39	Counter flange	Cast iron EN-GJL-200-EN 1561	1"¼	EBARA DRAWING	1
40	Counter flange gasket	NBR	-	EBARA DRAWING	1
41	Counter flange gasket	NBR	-	EBARA DRAWING	1
51	Tie rod	Galvanized Fe P04	M6	EBARA DRAWING	4
52	Capacitor box [5]	ABS class V-0	-	-	1
53	Capacitor box cover [5]	ABS class V-0	-	-	1
57	Pump side ball bearing spacer [6]	Steel C40	22x27x3	EBARA DRAWING	1
62	Stage housing	PPE+PS Glass fibre reinforced/PTFE	-	-	[1]
68	Stage	PPE+PS Glass fibre reinforced/PTFE	-	-	1
75	Washer	Aluminium	10x16x1,5	EBARA DRAWING	1
76	Washer	Aluminium	10x16x1,5	EBARA DRAWING	1
89	Washer	EN 1.4301 (AISI 304)	12x21x1 - [UP to 0,6kW] 14,1x22x1 - [0,75 kW and above]	EBARA DRAWING	1
91	Washer	EN 1.4301 (AISI 304)	8,4x17x1,6 - [UP to 0,6kW] 10,2x20x2,5 - [0,75 kW and above]	UNI EN ISO 7089 EBARA DRAWING	1
92	Lip seal	NBR	12x24x4 17x32x6	EBARA DRAWING	1
94	O-ring [9]	NBR	34.65x1.78	-	1
101	Seeger ring [6]	EN 1.4301 (AISI 304)	20	UNI 7435	1
110	Motor protector [7]	-	-	-	1
234	Washer	Galvanized steel	6,4x12,5x1,6	UNI EN ISO 7089	4

- [1] See CONSTRUCTION 4
[2] See CONSTRUCTION 3
[3] Only for three phase

- [4] See CONSTRUCTION 3
[5] Only for single phase
[6] Only for motor size 80

- [7] Only for motor size 71 e 80 single phase version
[8] Spacer – Only for A/8 3~model
[9] Only for A/12, B/12, A/15, AM/15, B/15, BM/15 models

(3/4)

Construction

Pump name CVM AM/10

Customer	Date 2024-06-13	Company
Contact	Item no.	Issued by
Phone	Project	Phone
E-mail	Project ID Project redenumit 2024-06-13 13:12:02	E-mail

Pump		POS. 7	POS. 9	POS. 62
A type	B type			
CVM A/4	-	2	1	1
CVM A/6	CVM B/10	3	2	2
CVM A/8	CVM B/12	4	3	3
CVM A/10	CVM B/15	5	4	4
CVM A/12	CVM B/20	6	5	5
CVM A/15	CVM B/23	7	6	6
CVM A/18	CVM B/25	8	7	7

(4/4)

Construction

Pump name CVM AM/10

Customer	Date 2024-06-13	Company
Contact	Item no.	Issued by
Phone	Project	Phone
E-mail	Project ID Proiect redenumit 2024-06-13 13:12:02	E-mail

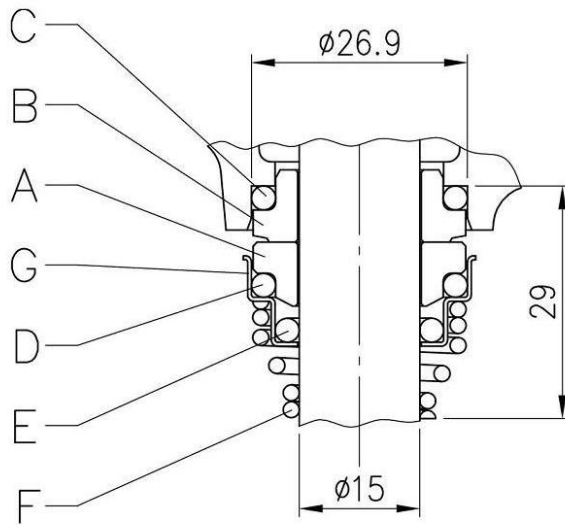

REF	PART NAME	MATERIAL product standard
A	Rotary seal ring	ceramic
B	Stationary seal ring	carbon graphite
C	O Ring	NBR
D	O Ring	NBR
E	O Ring	NBR
F	Self driving spring	AISI 316
G	Frame	AISI 304