

Technical Data

Pump Name

CVM AM/46

Customer	Date	2024-07-01	Company
Contact	Item no.		Issued by
Phone	Project		Phone
E-mail	Project ID	Proiect redenumit 2024-07-01 19:11:46	E-mail

Requested data

1	Pump type	MULTISTAGE CENTRIFUGAL PUMPS	Fluid	Water
2	Number of pumps / Reserve	1 / 0	Liquid temperature	°C
3	Flow	m³/h	Kin. viscosity	mm²/s
4	Head	m	Vapour pressure	bar
5	Geodetic head	m	PH value	
6	Inlet pressure (pin)	bar	Density	kg/m³
7	Available system NPSH		Solids	Weight %
8	Ambient temperature	°C		

Pump

9	Pump Name	CVM AM/46	Frequency	Hz	60	
10	Design	MULTISTAGE CENTRIFUGAL PUMPS	Installation type		STANDARD	
11	Manufacturer	EBARA	Impeller Diameter	Max.	mm	
12	Speed	rpm		3450	Designed	mm
13	No. of Stage			2	Min.	mm
14	Connection	Suction side	UNI ISO 228	Flow	Operating	
15	Connection	Discharge side	UNI ISO 228		Max-	m³/h
16	Max Working Pressure	bar	11		Min-	m³/h
17	Shut-off head	bar	2.55	Head	Operating	
18	Total weight	kg	See the table of "Dimensions".		- (Qmax.)	m
19	Shaft power	kW			- (Qmin.)	m
20				Max. Shaft Power at max. impeller	kW	
21	Required pump NPSH	m		Efficiency	%	

Materials

22	Impeller	PPE+PS Glass fibre reinforced		
23	Casing	Cast iron		
24	Shaft	AISI 416		
25				
26				
27				

Motor

28	Manufacturer	EPE Standard	Insulation class	F	
29	Type	TEFC_CVM AM/46_220_Single Phase	Phases	1~	
30	Specific design	- / 60 Hz / Pole pairs 1	Frame size	63	
31	Rated power	kW	0.3	Weight	kg
32	Number of poles		2	Electric voltage	V
33	Speed	rpm	3450	Electric current	A
34	Degree of protection		IP 44		
35					

Remarks

Performance Curve

Pump Name

CVM AM/46

Customer	Date	2024-07-01	Company
Contact	Item no.		Issued by
Phone	Project		Phone
E-mail	Project ID	Proiect redenumit 2024-07-01 19:11:46	E-mail

Requested data

1	Flow	m³/h	
2	Head	m	
3	Geodetic head	m	

Pump

Operating flow	m³/h		Frequency	Hz	60
Operating head	m		Number of poles		2
Impeller diameter designed	mm	90	Speed	rpm	3450

Test standard: ISO 9906:2012 - Grade3B

Water; 20°C; 998.3kg/m³; 1mm²/s

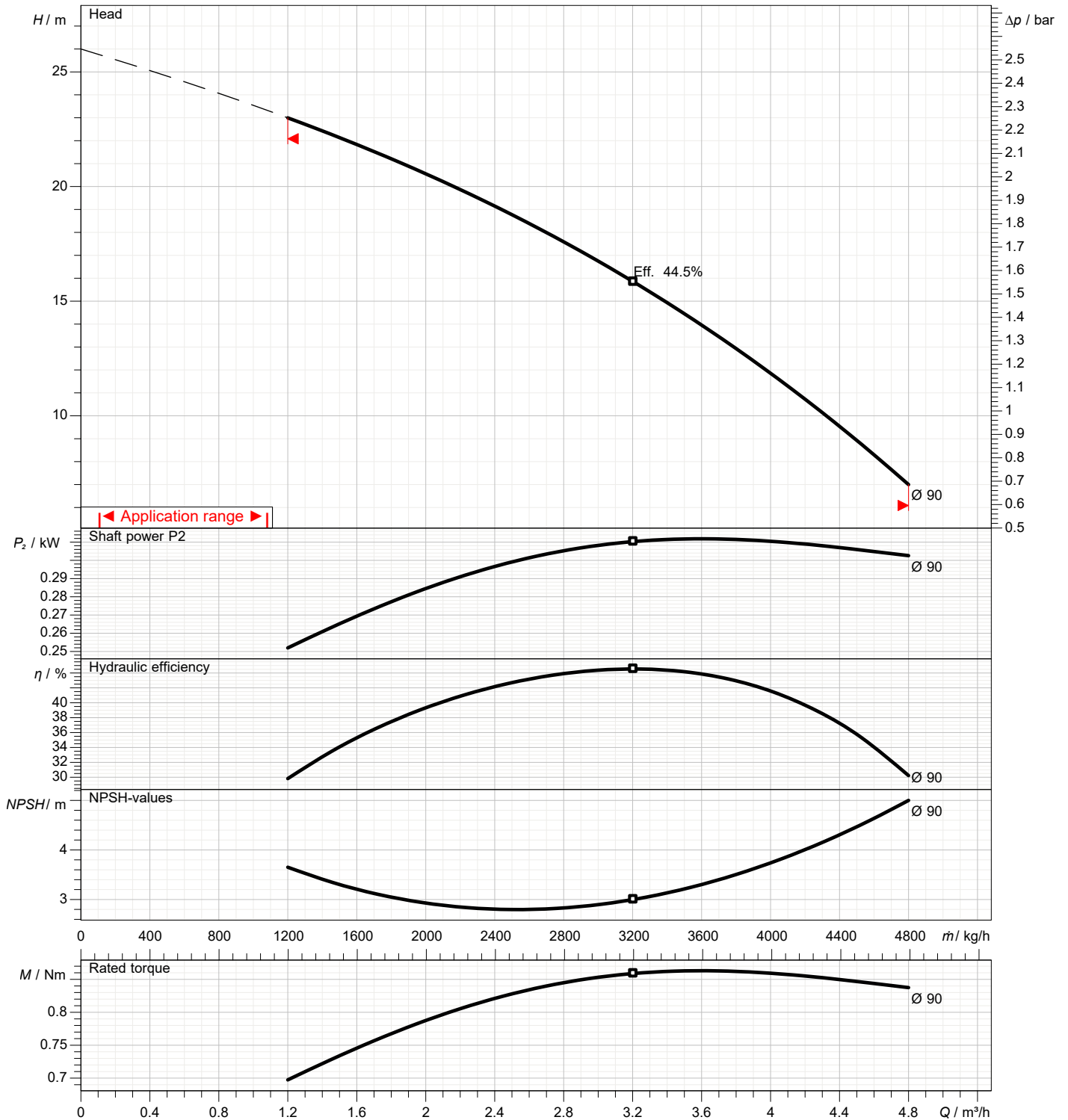

Dimensions

Pump name CVM AM/46

Customer	Date 2024-07-01	Company
Contact	Item no.	Issued by
Phone	Project	Phone
E-mail	Project ID Proiect redenumit 2024-07-01 19:11:46	E-mail

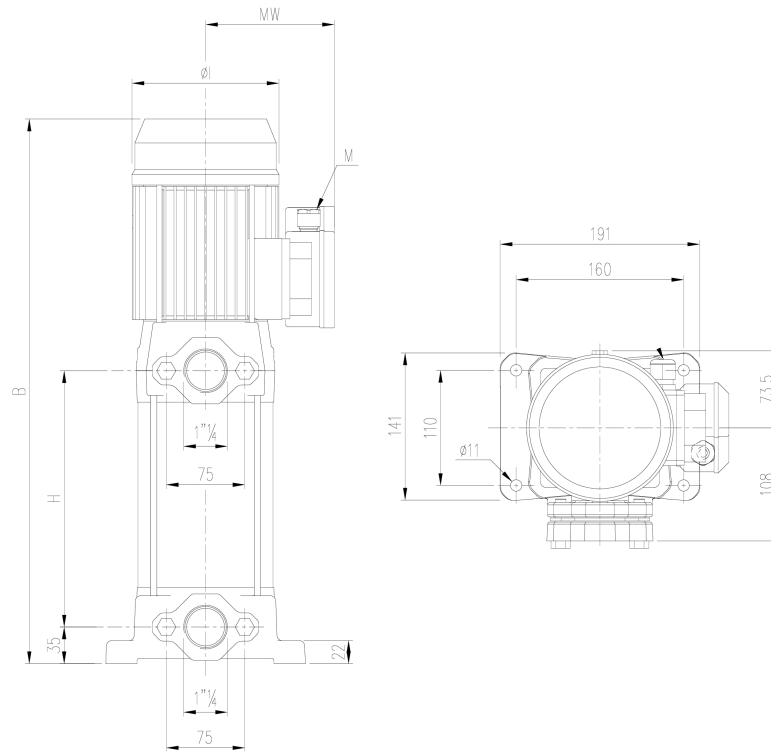

Dimensions in		mm						
1	B	336						
2	Dia l	124						
3	H	112						
4	M	PG11						
5	MW	101						
6	Weight P&M	11 kg						
7								
8								
9								
10								
11								
12								
13								
14								
15								

(1/4)

Construction

Pump name CVM AM/46

Customer	Date 2024-07-01	Company
Contact	Item no.	Issued by
Phone	Project	Phone
E-mail	Project ID Proiect redenumit 2024-07-01 19:11:46	E-mail

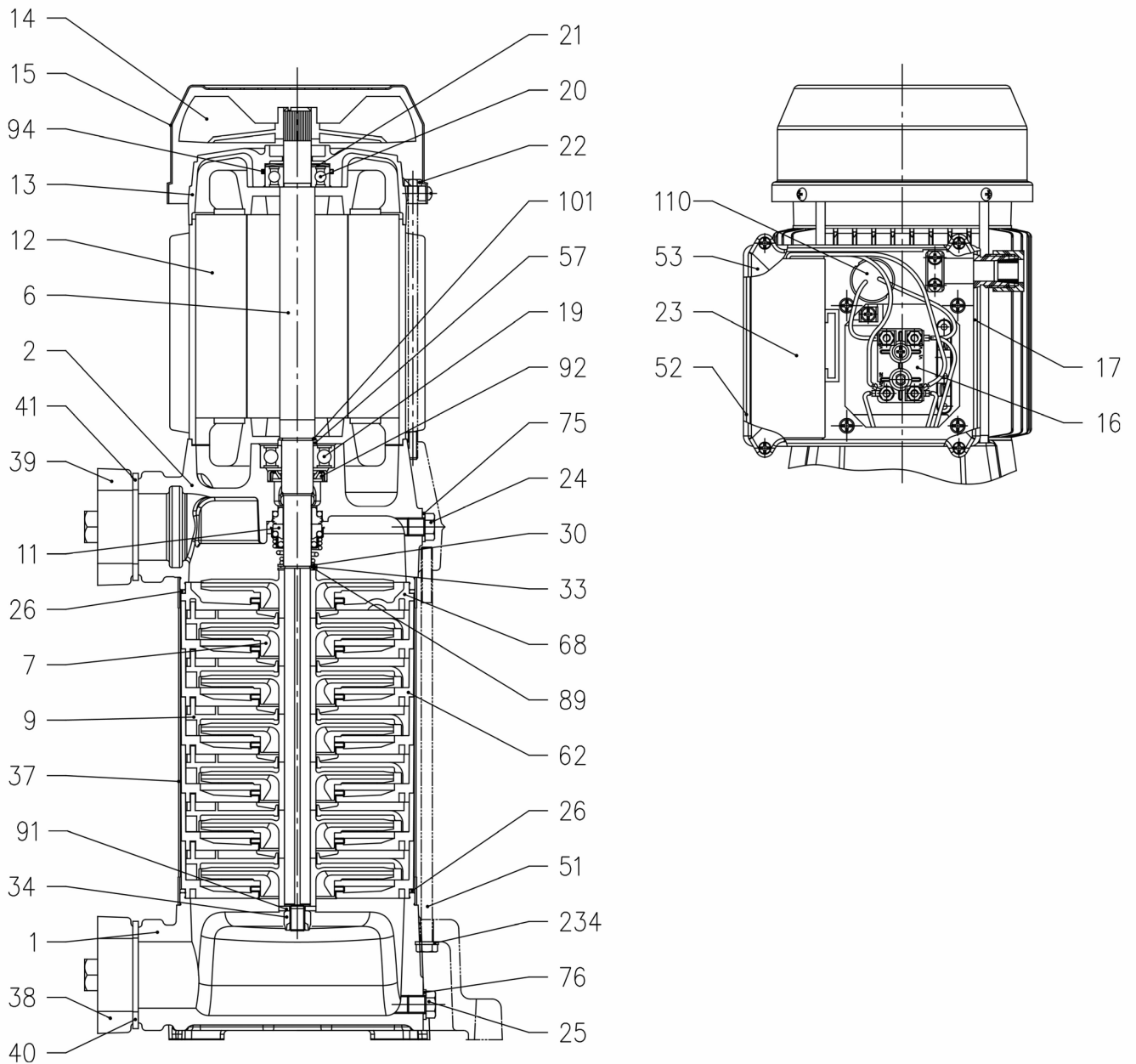

(2/4)

Construction

Pump name CVM AM/46

Customer	Date 2024-07-01	Company
Contact	Item no.	Issued by
Phone	Project	Phone
E-mail	Project ID Proiect redenumit 2024-07-01 19:11:46	E-mail

N°	PART NAME	MATERIAL	DIMENSIONS	STANDARD	Q.TY
1	Suction casing	Cast iron EN-GJL-200-EN 1561	-	-	1
2	Delivery casing	Cast iron EN-GJL-200-EN 1561	-	-	1
6	Shaft with rotor	EN 1.4005 (AISI 416)	-	-	1
7	Impeller	PPE+PS Glass fibre reinforced	-	-	[1]
9	Diffuser	PPE+PS Glass fibre reinforced	-	-	[1]
11	Mechanical seal [2]	Carbon / Ceramic / NBR	-	-	1
12	Motor frame with stator	-	-	-	1
13	Motor cover + Spacer [9]	Aluminium	-	-	1
14	Fan	PA6	-	-	1
15	Fan cover	Galvanized Fe P04	-	-	1
16	Terminal board	-	-	-	1
17	Terminal box cover [3]	Aluminium	-	-	1
19	Pump side ball bearing	-	[4]	-	1
20	Fan side ball bearing	-	[4]	-	1
21	Adjusting ring	Steel C70	-	-	1
22	Motor tie rod	Galvanized Fe 42	M5xL	EBARA DRAWING	4
23	Capacitor [5]	-	-	-	1
24	Priming plug	OT 58 UNI 5705	G 1/8"	UNI ISO 228	1
25	Drain plug	OT 58 UNI 5705	G 1/8"	UNI ISO 228	1
26	O-ring	NBR	120x3	-	2
30	Washer	EN 1.4301 (AISI 304)	12x22x1 - [UP to 0,6kW] 15x22x1 - [0,75 kW and above]	EBARA DRAWING	1
33	Seeger ring	EN 1.4021 (AISI 420) EN 1.4301 (AISI 304)	12 14	UNI 7435 JIS B2804-1978	1
34	Impeller nut	EN 1.4301 (AISI 304)	M8x1 - [UP to 0,6kW] M10x1,25 - [0,75 kW and above]	UNI 7474	1
37	External pump casing	EN 1.4301 (AISI 304)	-	-	1
38	Counter flange	Cast iron EN-GJL-200-EN 1561	1 1/4"	EBARA DRAWING	1
39	Counter flange	Cast iron EN-GJL-200-EN 1561	1 1/4"	EBARA DRAWING	1
40	Counter flange gasket	NBR	-	EBARA DRAWING	1
41	Counter flange gasket	NBR	-	EBARA DRAWING	1
51	Tie rod	Galvanized Fe P04	M6	EBARA DRAWING	4
52	Capacitor box [5]	ABS class V-0	-	-	1
53	Capacitor box cover [5] [8]	ABS class V-0 [8]	-	-	1
57	Pump side ball bearing spacer [6]	Steel C40	22x27x3	EBARA DRAWING	1
62	Stage housing	PPE+PS Glass fibre reinforced/PTFE	-	-	[1]
68	Stage	PPE+PS Glass fibre reinforced/PTFE	-	-	1
75	Washer	Aluminium	10x16x1,5	EBARA DRAWING	1
76	Washer	Aluminium	10x16x1,5	EBARA DRAWING	1
89	Washer	EN 1.4301 (AISI 304)	12x21x1 - [UP to 0,6kW] 14,1x22x1 - [0,75 kW and above]	EBARA DRAWING	1
91	Washer	EN 1.4301 (AISI 304)	8,4x17x1,6 - [UP to 0,6kW] 10,2x20x2,5 - [0,75 kW and above]	UNI EN ISO 7089 EBARA DRAWING	1
92	Lip seal	NBR	12x24x4 17x32x6	EBARA DRAWING	1
94	O-ring [10]	NBR	34.65x1.78	-	1
101	Seeger ring [6]	EN 1.4301 (AISI 304)	20	UNI 7435	1
110	Motor protector [7]	-	-	-	1
234	Washer	Galvanized steel	6,4x12,5x1,6	UNI EN ISO 7089	4

[1] See CONSTRUCTION 3

[2] See CONSTRUCTION 3

[3] Only for three phase

[4] See CONSTRUCTION 3

[5] Only for single phase

[6] Only for motor size 80

[7] Only for motor size 71 e 80 single phase version

[8] With gasket in NBR only for version single phase:

CVM A from 0.3 kW up to 1.1 Kw

CVM B from 0.75 kW up to 1.1 Kw

[9] Spacer – Only for A/8 three phase model

[10] Only for A/126, B/126, AM/156, A/156, BM/156, B/156 models

(3/4)

Construction

Pump name CVM AM/46

Customer	Date 2024-07-01	Company
Contact	Item no.	Issued by
Phone	Project	Phone
E-mail	Project ID Project redenumit 2024-07-01 19:11:46	E-mail

Pump		POS. 7	POS. 9	POS. 62
A type	B type			
CVM A/46	-	2	1	1
CVM A/66	CVM B/106	3	2	2
CVM A/86	CVM B/126	4	3	3
CVM A/106	CVM B/156	5	4	4
CVM A/126	CVM B/206	6	5	5
CVM A/156	CVM B/236	7	6	6
CVM A/186	CVM B/256	8	7	7

(4/4)

Construction

Pump name CVM AM/46

Customer	Date 2024-07-01	Company
Contact	Item no.	Issued by
Phone	Project	Phone
E-mail	Project ID Proiect redenumit 2024-07-01 19:11:46	E-mail

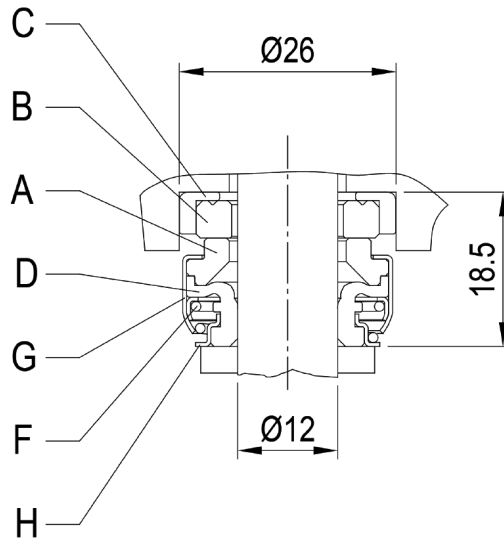

REF	PART NAME	MATERIAL Standard version
A	Rotary seal ring	carbon graphite
B	Stationary seal ring	ceramic
C	Gasket	NBR
D	Bellows	NBR
F	Self driving spring	AISI 304
G	Frame	AISI 304
H	Retainer ring	AISI 304