

Technical Data

Pump Name

DWC-V 300/3.06

| | | | |
|----------|------------|---------------------------------------|-----------|
| Customer | Date | 2024-07-01 | Company |
| Contact | Item no. | | Issued by |
| Phone | Project | | Phone |
| E-mail | Project ID | Proiect redenumit 2024-07-01 19:11:46 | E-mail |

Requested data

| | | | | |
|---|---------------------------|-------------------|--------------------|-------------|
| 1 | Pump type | CENTRIFUGAL PUMPS | Fluid | Water |
| 2 | Number of pumps / Reserve | 1 / 0 | Liquid temperature | °C 20 |
| 3 | Flow m³/h | | Kin. viscosity | mm²/s 1.005 |
| 4 | Head m | | Vapour pressure | bar 0.0234 |
| 5 | Geodetic head m | | PH value | |
| 6 | Inlet pressure (pin) bar | 0 | Density | kg/m³ 998.3 |
| 7 | Available system NPSH | | Solids | Weight % 0 |
| 8 | Ambient temperature °C | 20 | | |

Pump

| | | | | |
|----|---------------------------|--------------------------------|-----------------------------------|----------------------|
| 9 | Pump Name | DWC-V 300/3.06 | Frequency | Hz 60 |
| 10 | Design | CENTRIFUGAL PUMPS | Installation type | Victaulic Connection |
| 11 | Manufacturer | EBARA | Impeller Diameter | Max. mm 148 |
| 12 | Speed rpm | 3450 | | Designed mm 148 |
| 13 | No. of Stage | 1 | | Min. mm 148 |
| 14 | Connection Suction side | | Flow | Operating m³/h |
| 15 | Connection Discharge side | | | Max- m³/h 27 |
| 16 | Max Working Pressure bar | 8 | | Min- m³/h 6 |
| 17 | Shut-off head bar | 3.43 | Head | Operating m |
| 18 | Total weight kg | See the table of "Dimensions". | | - (Qmax.) m 19.7 |
| 19 | Shaft power kW | | | - (Qmin.) m 33.7 |
| 20 | | | Max. Shaft Power at max. impeller | kW 2.55 |
| 21 | Required pump NPSH m | | Efficiency | % |

Materials

| | | | |
|----|----------|--------------------------|--|
| 22 | Impeller | AISI 304 | |
| 23 | Casing | AISI 304 | |
| 24 | Shaft | AISI 304 (wet extension) | |
| 25 | | | |
| 26 | | | |
| 27 | | | |

Motor

| | | | | |
|----|----------------------|-----------------------------------|------------------|--------|
| 28 | Manufacturer | EPE Standard | Insulation class | F |
| 29 | Type | TEFC_DWC 300/3.06_220_Three Phase | Phases | 3~ |
| 30 | Specific design | IE2 / 60 Hz / Pole pairs 1 | Frame size | |
| 31 | Rated power kW | 3 | Weight | kg |
| 32 | Number of poles | 2 | Electric voltage | V 220 |
| 33 | Speed rpm | 3450 | Electric current | A 10.2 |
| 34 | Degree of protection | IP 55 | | |
| 35 | | | | |

Remarks

Performance Curve

Pump Name

DWC-V 300/3.06

| | | | |
|----------|------------|---------------------------------------|-----------|
| Customer | Date | 2024-07-01 | Company |
| Contact | Item no. | | Issued by |
| Phone | Project | | Phone |
| E-mail | Project ID | Project redenumit 2024-07-01 19:11:46 | E-mail |

Requested data

| | | | |
|---|---------------|------|--|
| 1 | Flow | m³/h | |
| 2 | Head | m | |
| 3 | Geodetic head | m | |

Pump

| | | | | | |
|----------------------------|------|-----|-----------------|-----|------|
| Operating flow | m³/h | | Frequency | Hz | 60 |
| Operating head | m | | Number of poles | | 2 |
| Impeller diameter designed | mm | 148 | Speed | rpm | 3450 |

Test standard: ISO 9906:2012 - Grade3B

Water; 20°C; 998.3kg/m³; 1mm²/s

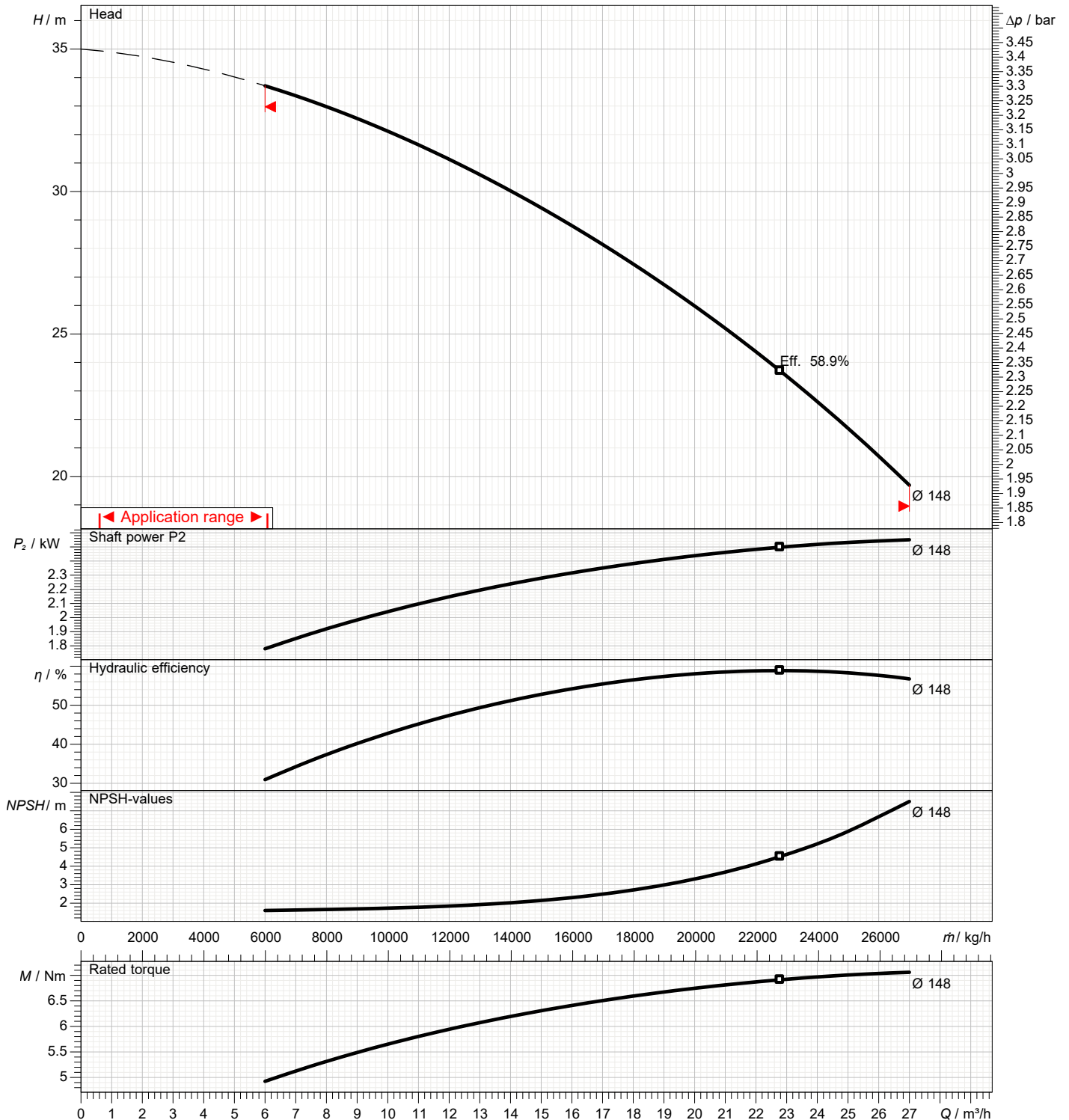

Dimensions

Pump Name **DWC-V 300/3.06**

| | | |
|----------|--|-----------|
| Customer | Date 2024-07-01 | Company |
| Contact | Item no. | Issued by |
| Phone | Project | Phone |
| E-mail | Project ID Proiect redenumit 2024-07-01 19:11:46 | E-mail |

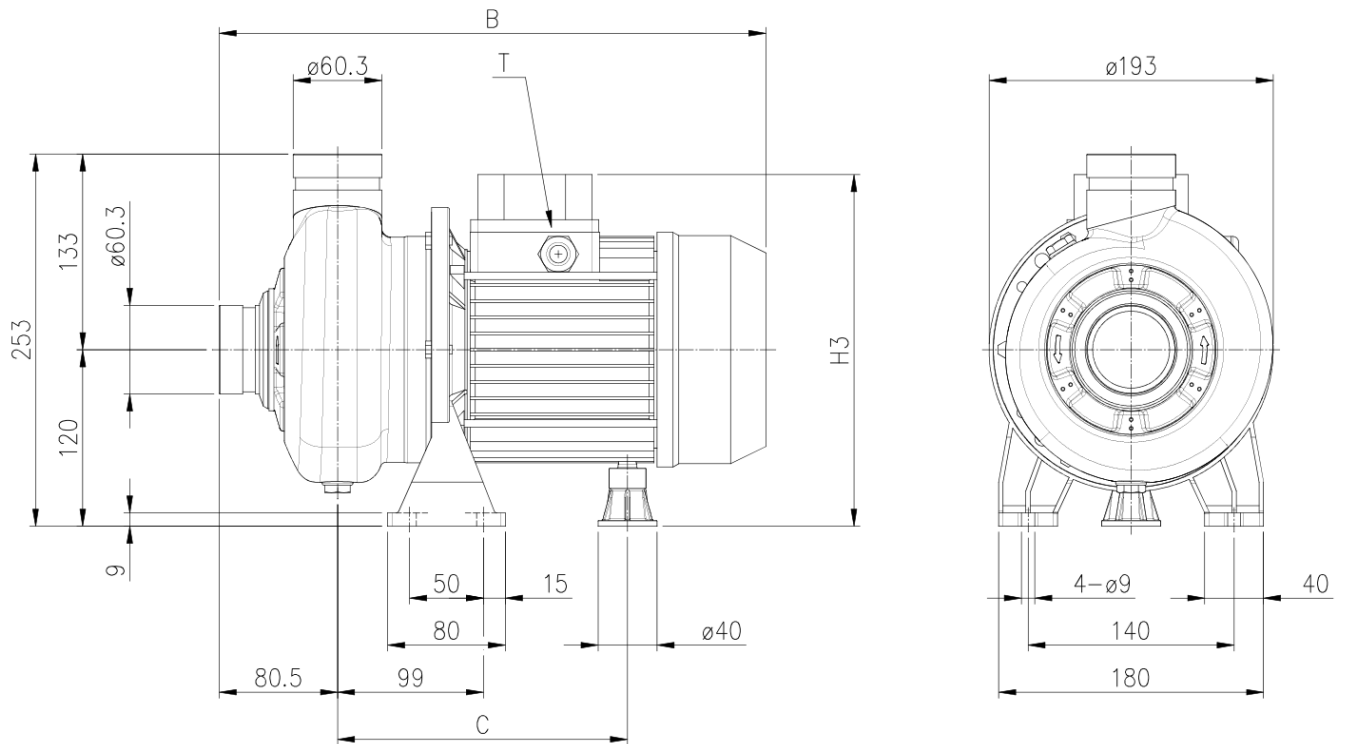

| Dimensions in | | mm | | | | | | |
|---------------|------------|---------|--|--|--|--|--|--|
| 1 | B | 457 | | | | | | |
| 2 | C | 471 | | | | | | |
| 3 | H3 | 244 | | | | | | |
| 4 | T | PG 13,5 | | | | | | |
| 5 | Weight P&M | 22 kg | | | | | | |
| 6 | | | | | | | | |
| 7 | | | | | | | | |
| 8 | | | | | | | | |
| 9 | | | | | | | | |
| 10 | | | | | | | | |
| 11 | | | | | | | | |
| 12 | | | | | | | | |
| 13 | | | | | | | | |
| 14 | | | | | | | | |
| 15 | | | | | | | | |

(1/3)

Construction

Pump Name **DWC-V 300/3.06**

| | | |
|----------|--|-----------|
| Customer | Date 2024-07-01 | Company |
| Contact | Item no. | Issued by |
| Phone | Project | Phone |
| E-mail | Project ID Proiect redenumit 2024-07-01 19:11:46 | E-mail |

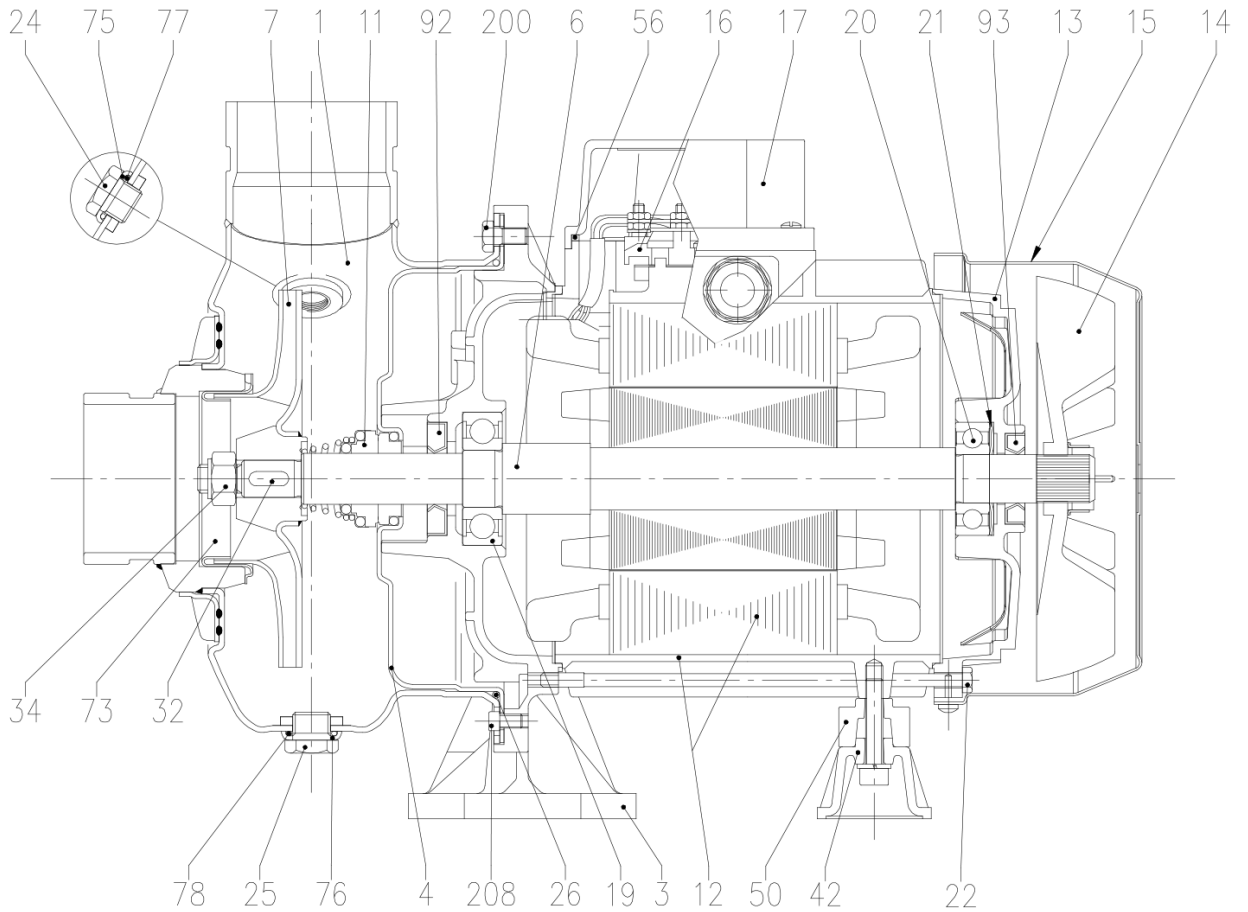

(2/3)

Construction

Pump Name DWC-V 300/3.06

| | | | |
|----------|------------|---------------------------------------|-----------|
| Customer | Date | 2024-07-01 | Company |
| Contact | Item no. | | Issued by |
| Phone | Project | | Phone |
| E-mail | Project ID | Proiect redenumit 2024-07-01 19:11:46 | E-mail |

| N° | PART NAME | MATERIAL | DIMENSIONS | STANDARD | Q.TY |
|-----|-------------------------|--|--------------------|----------------------------|------|
| 1 | Casing | EN 1.4301 (AISI 304) | | | 1 |
| 3 | Motor bracket | Aluminium | | | 1 |
| 4 | Casing cover | EN 1.4301 (AISI 304) | | | 1 |
| 6 | Shaft with rotor | EN 1.4301(AISI 304)-Wet extension | | | 1 |
| 7 | Impeller | EN 1.4301 (AISI 304) | | | 1 |
| 11 | Mechanical seal [3] | Ceramic / Carbon / EPDM | | | 1 |
| 12 | Motor frame with stator | - | | | 1 |
| 13 | Motor cover | Aluminium | | | 1 |
| 14 | Fan | PA | | | 1 |
| 15 | Fan cover | Fe P04 Zincate | | | 1 |
| 16 | Terminal board | - | | | 1 |
| 17 | Terminal board cover | Aluminium | | | 1 |
| 19 | Bearing | - | | | 1 |
| 20 | Bearing | - | | | 1 |
| 21 | Adjusting ring | Steel C70 | | | 1 |
| 22 | Tie rod | Fe 42 Zincate | | EBARA drawing | 4 |
| 24 | Priming plug | EN 1.4301 (AISI 304) | G 1/4" | EBARA drawing | 1 |
| 25 | Draing plug | EN 1.4301 (AISI 304) | G 1/4" | EBARA drawing | 1 |
| 26 | O-ring [2] | EPDM / FPM | 148.8x3.53 | OR 4587 | 1 |
| 32 | Key | EN 1.4401 (AISI 316) | 5x5x16 | UNI 6604 | 1 |
| 34 | Impeller nut | EN 1.4301 (AISI 304) | M10x1.25 | UNI 7474 | 1 |
| 42 | Foot | Aluminium / Zincate steel | | EBARA drawing | 1 |
| 50 | Spacer | - | | | [1] |
| 56 | Box gasket | NBR | | | 1 |
| 73 | Casing ring | EN 1.4301 (AISI 304) | | | 1 |
| 75 | Washer | EN 1.4301 (AISI 304) | | EBARA drawing | 1 |
| 76 | Washer | EN 1.4301 (AISI 304) | | EBARA drawing | 1 |
| 77 | O-ring [2] | EPDM / FPM | 13.1x2.62 | OR 117 | 1 |
| 78 | O-ring [2] | EPDM / FPM | 13.1x2.62 | OR 117 | 1 |
| 92 | Lip seal | - | 18x40x7 | DIN 3760 without spring | 1 |
| 93 | Lip seal | Up to 1.5 kW For 2.2 and 3.0 kW | 17x32x7 25x40x7 | DIN 3760 without spring | 1 |
| 200 | Screw | Stainless steel A2-70 class ISO 3506/1 | M 6x12 | UNI 5739 | 6 |
| 208 | Screw | Stainless steel A2-70 class ISO 3506/1 | M 5x12 | UNI 5931 | 4 |

[1] Q.TY=1 only for 1,1 kW and 1,5 kW

[2] FPM for H-HS-HW-HSW-Q1AVGG

EPDM for Standard-AQ1EGG-VAEGG-Q1U3EGG-U3BEGG

[3] See **CONSTRUCTION 3**

(3/3)

Construction

Pump Name **DWC-V 300/3.06**

| | | |
|----------|--|-----------|
| Customer | Date 2024-07-01 | Company |
| Contact | Item no. | Issued by |
| Phone | Project | Phone |
| E-mail | Project ID Proiect redenumit 2024-07-01 19:11:46 | E-mail |

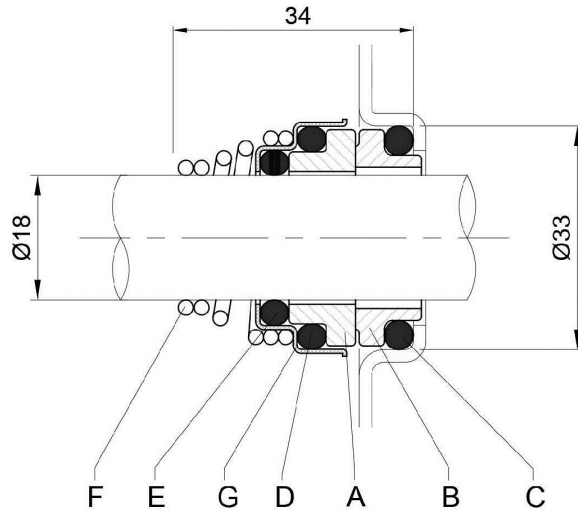

| REF | PART NAME | MATERIAL Standard |
|-----|----------------------|-------------------|
| A | Rotary seal ring | Ceramic |
| B | Stationary seal ring | Carbon graphite |
| C | O-ring | EPDM |
| D | O-ring | EPDM |
| E | O-ring | EPDM |
| F | Self driving spring | AISI 316 |
| G | Frame | AISI 304 |