

# Technical Data

Pump Name

DWO 2006 M

Customer	Date	2024-07-01	Company
Contact	Item no.		Issued by
Phone	Project		Phone
E-mail	Project ID	Proiect redenumit 2024-07-01 19:11:46	E-mail

## Requested data

1	Pump type	CENTRIFUGAL PUMPS	Fluid	Water
2	Number of pumps / Reserve	1 / 0	Liquid temperature	°C
3	Flow	m³/h	Kin. viscosity	mm²/s
4	Head	m	Vapour pressure	bar
5	Geodetic head	m	PH value	
6	Inlet pressure (pin)	bar	Density	kg/m³
7	Available system NPSH		Solids	Weight %
8	Ambient temperature	°C		

## Pump

9	Pump Name	DWO 2006 M	Frequency	Hz	60	
10	Design	CENTRIFUGAL PUMPS	Installation type		STANDARD	
11	Manufacturer	EBARA	Impeller Diameter	Max.	mm	
12	Speed	rpm		3400	Designed	mm
13	No. of Stage	1		Min.	mm	88
14	Connection	Suction side	UNI ISO 228	Flow	Operating	m³/h
15	Connection	Discharge side	UNI ISO 228		Max-	m³/h
16	Max Working Pressure	bar	8		Min-	m³/h
17	Shut-off head	bar	1.35	Head	Operating	m
18	Total weight	kg	See the table of "Dimensions".		- (Qmax.)	m
19	Shaft power	kW			- (Qmin.)	m
20				Max. Shaft Power at max. impeller	kW	
21	Required pump NPSH	m		Efficiency	%	

## Materials

22	Impeller	AISI 304		
23	Casing	AISI 304		
24	Shaft	AISI 304 (wet extension)		
25				
26				
27				

## Motor

28	Manufacturer	EPE Standard	Insulation class	F	
29	Type	TEFC_DWO 2006 M_220_Single Phase	Phases	1~	
30	Specific design	- / 60 Hz / Pole pairs 1	Frame size		
31	Rated power	kW	1.5	Weight	kg
32	Number of poles	2	Electric voltage	V	220
33	Speed	rpm	3450	Electric current	A
34	Degree of protection	IP 55			
35					

## Remarks

# Performance Curve

Pump Name

DWO 2006 M

Customer	Date	2024-07-01	Company
Contact	Item no.		Issued by
Phone	Project		Phone
E-mail	Project ID	Proiect redenumit 2024-07-01 19:11:46	E-mail

## Requested data

1	Flow	m³/h	
2	Head	m	
3	Geodetic head	m	

## Pump

Operating flow	m³/h		Frequency	Hz	60
Operating head	m		Number of poles		2
Impeller diameter designed	mm	88	Speed	rpm	3400

Test standard: ISO 9906:2012 - Grade3B

Water; 20°C; 998.3kg/m³; 1mm²/s

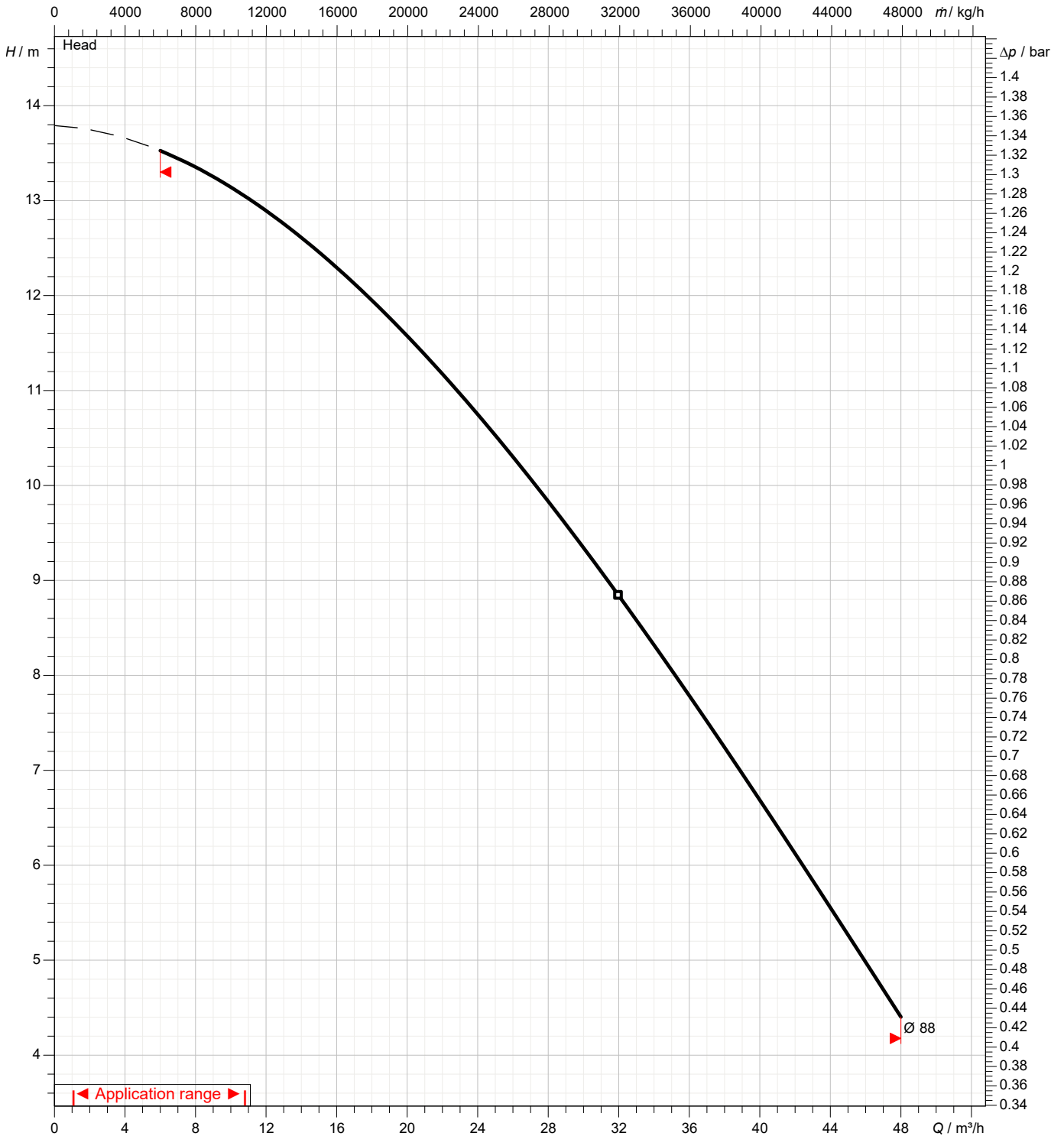

# Dimensions

Pump Name DWO 2006 M

Customer	Date 2024-07-01	Company
Contact	Item no.	Issued by
Phone	Project	Phone
E-mail	Project ID Proiect redenumit 2024-07-01 19:11:46	E-mail

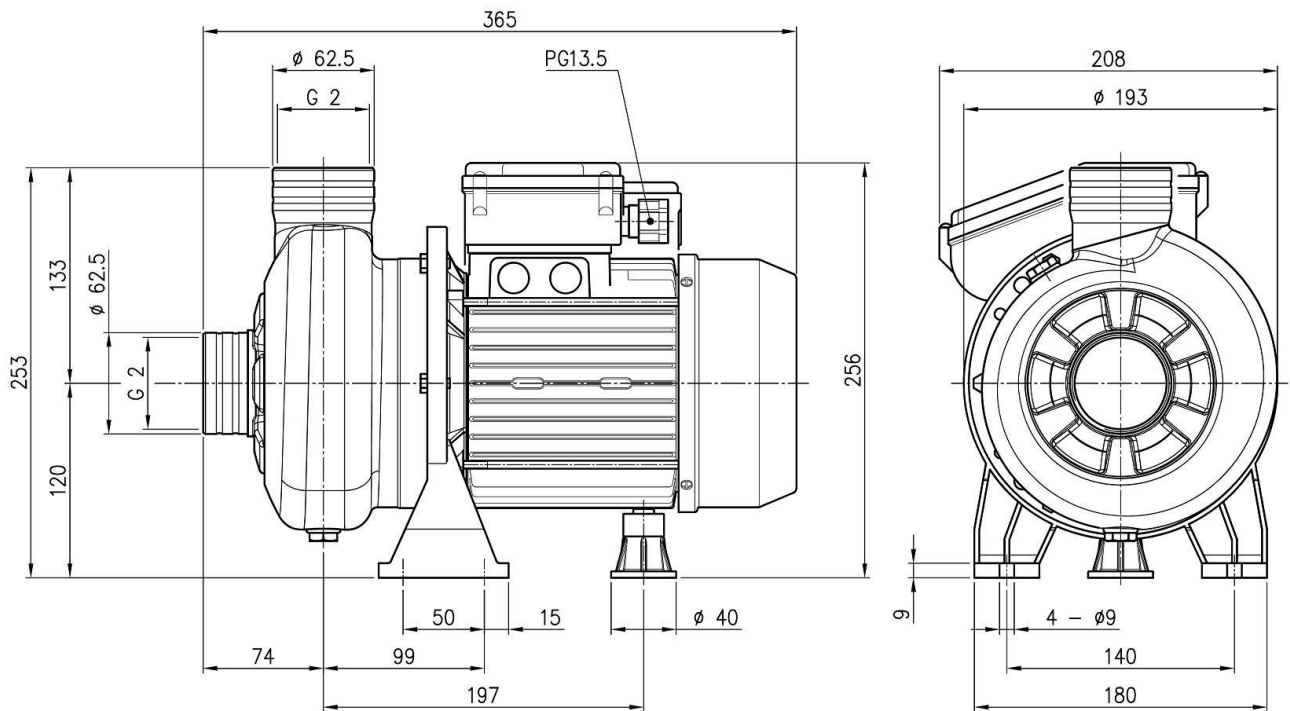

Dimensions in		mm						
1	Weight P&M	15.7 kg						
2								
3								
4								
5								
6								
7								
8								
9								
10								
11								
12								
13								
14								
15								

(1/3)

# Construction

Pump Name DWO 2006 M

Customer	Date 2024-07-01	Company
Contact	Item no.	Issued by
Phone	Project	Phone
E-mail	Project ID Proiect redenumit 2024-07-01 19:11:46	E-mail

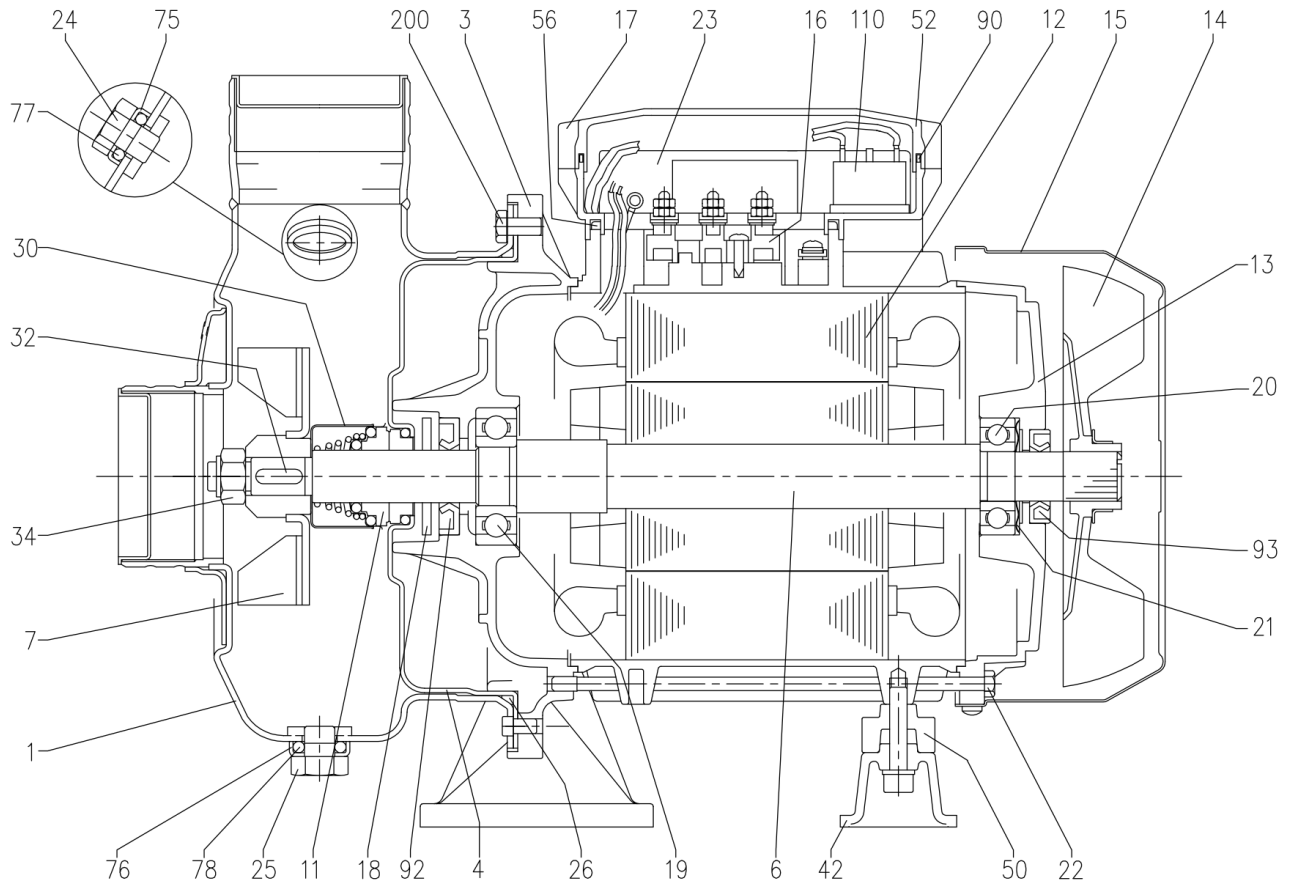

(2/3)

# Construction

Pump Name DWO 2006 M

Customer	Date 2024-07-01	Company
Contact	Item no.	Issued by
Phone	Project	Phone
E-mail	Project ID Project redenumit 2024-07-01 19:11:46	E-mail

N°	PART NAME	MATERIAL	Q.TY
1	Casing	AISI 304	1
3	Motor bracket	Aluminium	1
4	Casing cover	AISI 304	1
6	Shaft with rotor	AISI 304 (Wet extention)	1
7	Impeller	AISI 304	1
11	Mechanical seal [3]	Carbon/Ceramic/NBR	1
12	Motor frame with stator	-	1
13	Motor cover	Aluminium	1
14	Fan	PP	1
15	Fan cover	Fe P04 Zincate	1
16	Terminal box	-	1
17	Terminal box cover [2]	Aluminium	1
18	Splash ring	NBR	1
19	Pump side ball bearing	-	1
20	Fan side ball bearing	-	1
21	Adjusting ring	Steel C70	1
22	Tie rod	Fe 420 Zincate	4
23	Capacitor [1]	-	1
24	Priming plug	AISI 303	1
25	Drain plug	AISI 303	1
26	O-ring [4]	NBR/FPM/EPDM	1
30	Mechanical seal protection	AISI 304	1
32	Key	AISI 316	1
34	Impeller nut	AISI 304	1
42	Motor support	Aluminium	1
50	Spacer	-	1
52	Terminal box [1]	PP	1
56	Box gasket	NBR	1
75	Washer	AISI 304	1
76	Washer	AISI 304	1
77	O-ring [4]	NBR/FPM/EPDM	1
78	O-ring [4]	NBR/FPM/EPDM	1
90	Terminal box cover gasket [1]	NBR	1
92	Lip seal	-	1
93	Lip seal	-	1
110	Protector [1]	-	1
200	Screw	Stainless steel A2 UNI7323	6

[1] Only for Single phase

[2] Only for Three phase

[3] See **CONSTRUCTION 3**

[4] FPM for H-HS-HW-HSW-Q1AVGG

EPDM for AQ1EGG-VAEGG-Q1U3EGG-U3BEGG

NBR only for Standard version

(3/3)

# Construction

Pump Name DWO 2006 M

Customer	Date 2024-07-01	Company
Contact	Item no.	Issued by
Phone	Project	Phone
E-mail	Project ID Proiect redenumit 2024-07-01 19:11:46	E-mail

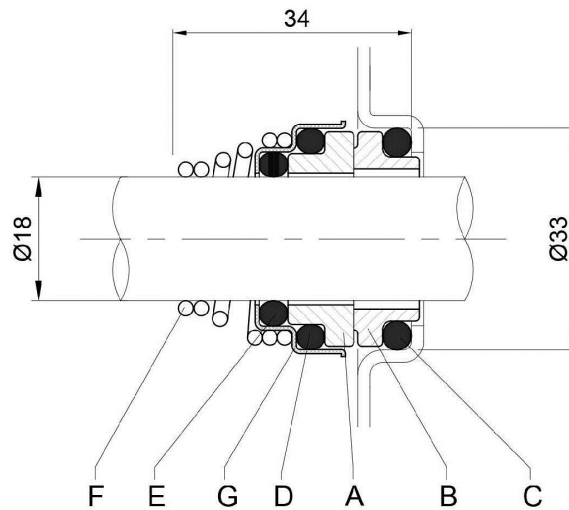

REF	PART NAME	MATERIAL Standard
A	Rotary seal ring	Ceramic
B	Stationary seal ring	Carbon graphite
C	O-ring	NBR
D	O-ring	NBR
E	O-ring	NBR
F	Self driving spring	AISI 316
G	Frame	AISI 304