

Technical Data

Pump Name

EGO 25/80-180

Customer	Date	2024-06-13	Company
Contact	Item no.		Issued by
Phone	Project		Phone
E-mail	Project ID	Proiect redenumit 2024-06-13 20:42:34	E-mail

Requested data

1	Pump type	THREADED CIRCULATORS	Fluid	Water
2	Number of pumps / Reserve	1 / 0	Liquid temperature	°C
3	Flow	m³/h	Kin. viscosity	mm²/s
4	Head	m	Vapour pressure	bar
5	Geodetic head	m	PH value	
6	Inlet pressure (pin)	bar	Density	kg/m³
7	Available system NPSH		Solids	Weight %
8	Ambient temperature	°C		

Pump

9	Pump Name	EGO 25/80-180	Frequency	Hz	50	
10	Design	THREADED CIRCULATORS	Installation type		Single Circulation	
11	Manufacturer	EBARA	Impeller Diameter	Max.	mm	
12	Speed	rpm		4800	Designed	mm
13	No. of Stage	1		Min.	mm	0
14	Connection	Suction side	Flow	Operating	m³/h	
15	Connection	Discharge side		Max-	m³/h	3.6
16	Max Working Pressure	bar		Min-	m³/h	0.6
17	Shut-off head	bar	Head	Operating	m	
18	Total weight	kg		- (Qmax.)	m	0.1
19	Shaft power	kW		- (Qmin.)	m	6.6
20			Max. Shaft Power at max. impeller	kW	0.06	
21	Required pump NPSH	m	Efficiency	%		

Materials

22	Impeller	NORYL 1630V		
23	Casing	Gray cast iron with cataphoresis protection		
24	Shaft	Ceramics		
25				
26				
27				

Motor

28	Manufacturer	EPE Standard	Insulation class	F	
29	Type	EGO 25/80-180_230_Single Phase	Phases	1~	
30	Specific design	- / 50 Hz / Pole pairs 1	Frame size		
31	Rated power	kW	Weight	kg	
32	Number of poles	2	Electric voltage	V	
33	Speed	rpm	4800	Electric current	A
34	Degree of protection	IP 44			
35					

Remarks

Performance curve

Pump name EGO 25/80-180

Customer	Date	2024-06-13	Company
Contact	Item no.		Issued by
Phone	Project		Phone
E-mail	Project ID	Proiect redenumit 2024-06-13 20:42:34	E-mail

Requested data

1	Flow	m ³ /h	
2	Head	m	
3	Geodetic head	m	

Pump

Operating flow	m ³ /h		Impeller Diameter Designed	mm	
Operating head	m		Frequency	Hz	50
			Speed	rpm	4800

Water; 20°C; 998.3kg/m³; 1mm²/s

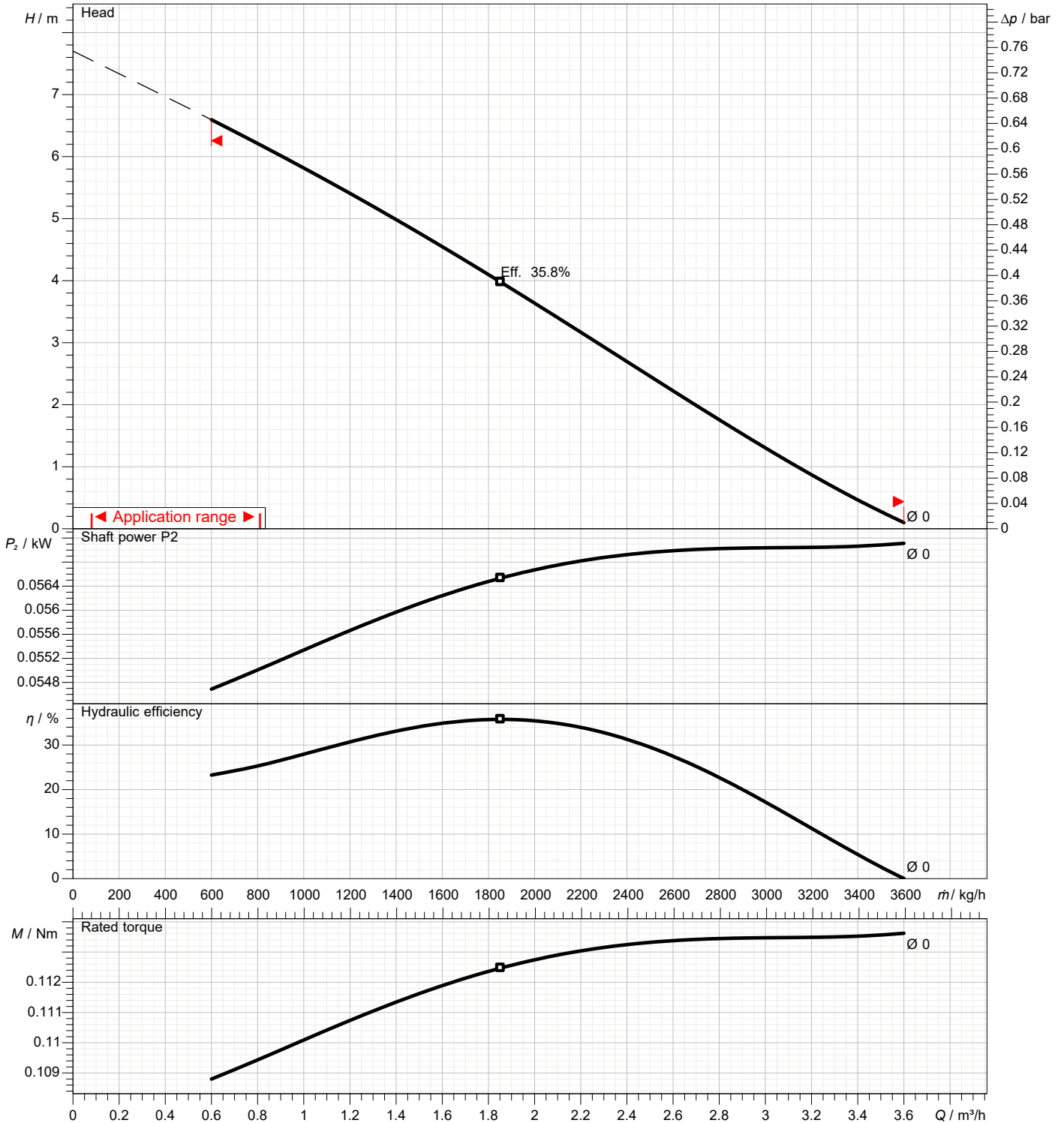

Dimensions

Pump name EGO 25/80-180

Customer	Date	2024-06-13	Company
Contact	Item no.		Issued by
Phone	Project		Phone
E-mail	Project ID	Proiect redenumit 2024-06-13 20:42:34	E-mail

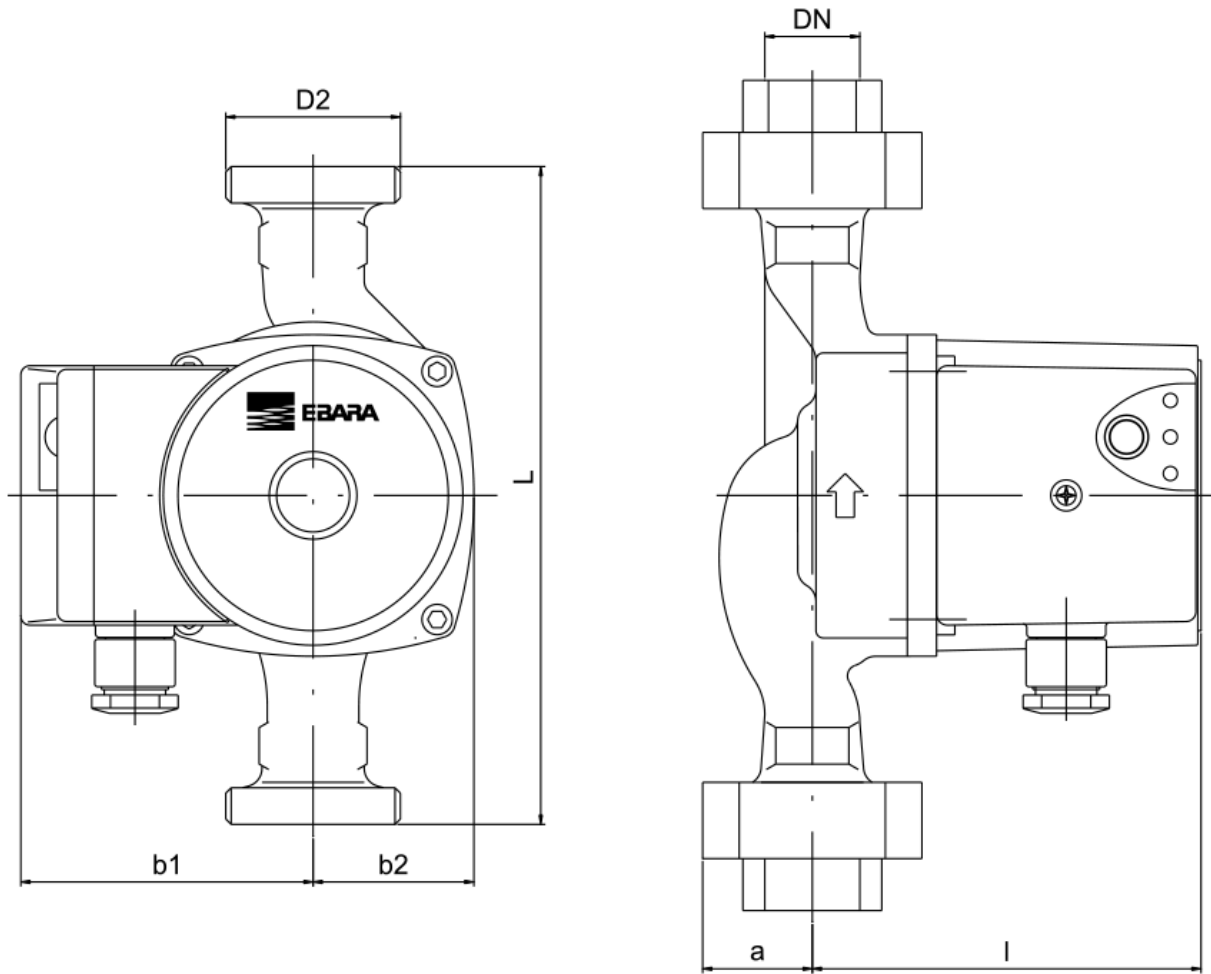

Dimensions in		mm						
1	a	32						
2	b1	80						
3	b2	48						
4	D2	1" 1/2						
5	DN	25						
6	l	108						
7	L	180						
8	Weight P&M	2,4 kg						
9								
10								
11								
12								
13								
14								
15								

(1/1)

Construction

Pump name EGO 25/80-180

Customer	Date 2024-06-13	Company
Contact	Item no.	Issued by
Phone	Project	Phone
E-mail	Project ID Proiect redenumit 2024-06-13 20:42:34	E-mail

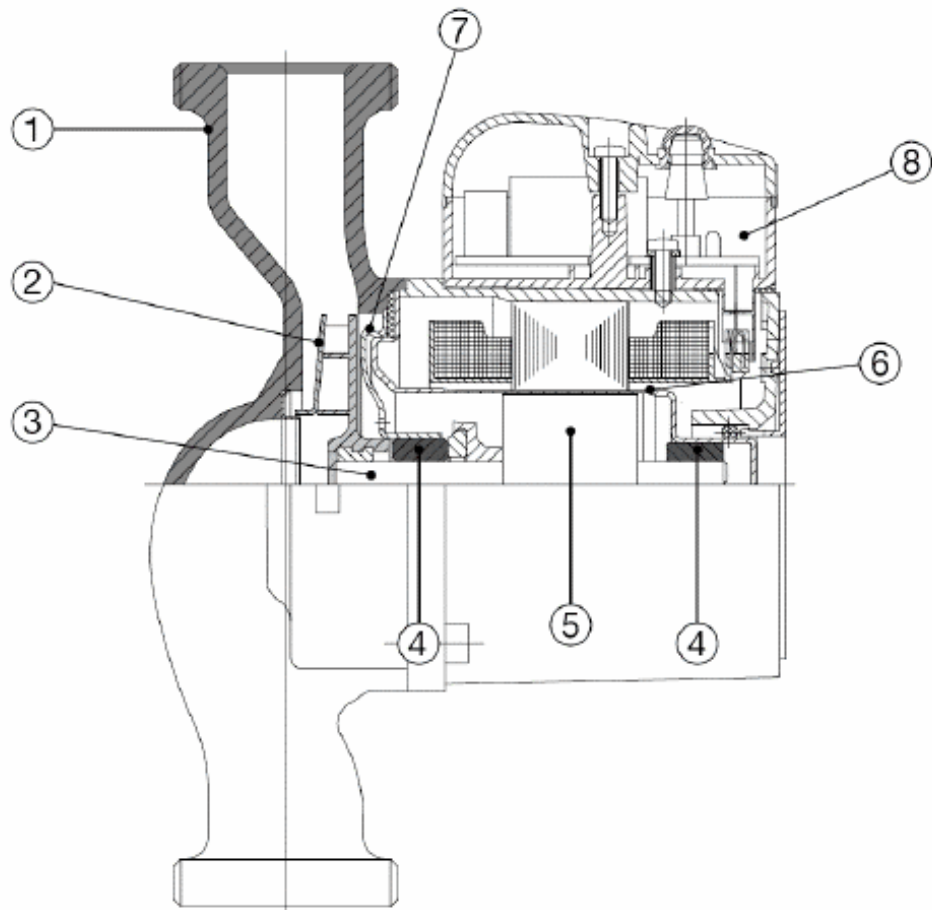

N°	Name	Material
1	Pump body	Cast iron with cataphoresis coating
2	Impeller	Noryl 1630V
3	Shaft	Ceramic
4	Bearings	Ceramic
5	Rotor	Coated in Stainless Steel
6	Rotor can	AISI 316 Stainless Steel
7	Bearing plate	AISI 316 Stainless Steel
8	Electronic board	-