

Technical data

Pump name EVMG32 14-0F5/30

Customer	Date 2024-06-13	Company
Contact	Item no.	Issued by
Phone	Project	Phone
E-mail	Project ID Proiect redenumit 2024-06-13 20:42:	E-mail

Requested data

1	Pump type	VERTICAL PUMPS	Fluid	Water
2	Number of pumps / Reserve	1 / 0	Liquid temperature °C	20
3	Flow m ³ /h		Kin. viscosity mm ² /s	1.005
4	Head m		Vapour pressure bar	0.0234
5	Geodetic head m		PH value	
6	Inlet pressure (pin) bar	0	Density kg/m ³	998.3
7	Available system NPSH		Solids Weight %	0
8	Ambient temperature °C	20		

Pump

9	Pump name	EVMG32 14-0F5/30	Frequency Hz	50
10	Design	VERTICAL PUMPS	Installation type	STANDARD
11	Manufacturer	EBARA	Impeller Diameter	Max. mm -
12	Speed rpm	2960		Designed mm
13	No. of Stage	14		Min. mm -
14	Connection Suction side		Flow	Operating m ³ /h
15	Connection Discharge side			Max- m ³ /h 42
16	Max Working Pressure bar	30		Min- m ³ /h 12
17	Shut-off head bar	32.31	Head	Operating m
18	Total weight kg	See the table of "Dimensions".		- (Qmax.) m 137.4
19	Shaft power kW			- (Qmin.) m 308.0
20			Max. Shaft Power at max. impeller kW	25.71
21	Required pump NPSH m		Efficiency %	

Materials

22	Impeller	AISI 304		
23	Intermediate casing	AISI 304		
24	Bottom casing	Cast iron		
25	Shaft	AISI 316		
26				
27				

Motor

28	Manufacturer	ATB	Insulation class	F
29	Type	TEFC_EVM32 14-0F5/30_400_Three Phase	Phases	3~
30	Specific design	IE3 / 50 Hz / Pole pairs 1	Frame size	200
31	Rated power kW	30	Weight kg	168
32	Number of poles	2	Electric voltage V	400
33	Speed rpm	2945	Electric current A	51
34	Degree of protection	IP 55		
35				

Remarks

Performance curve

Pump name **EVMG32 14-0F5/30**

Customer	Date	2024-06-13	Company
Contact	Item no.		Issued by
Phone	Project		Phone
E-mail	Project ID	Project redenumit 2024-06-13 20:42:	E-mail

Requested data

1	Flow	m ³ /h	
2	Head	m	
3	Geodetic head	m	

Pump

Operating flow	m ³ /h		Impeller Diameter Designed	mm	
Operating head	m		Frequency	Hz	50
			Speed	rpm	2960

Test standard: ISO 9906:2012 - Grade3B

Water; 20°C; 998.3kg/m³; 1mm²/s

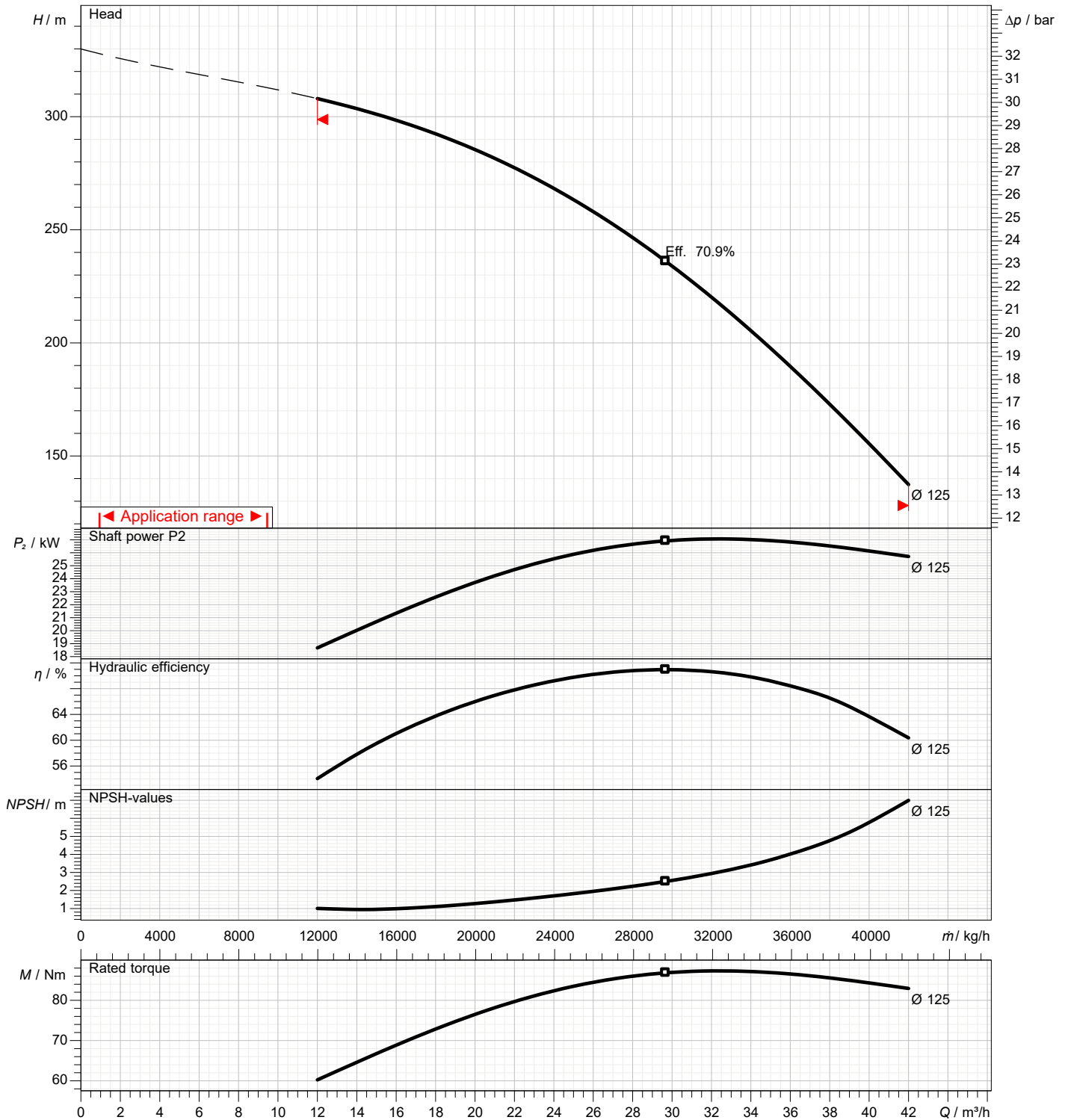

Dimensions

Pump name EVMG32 14-0F5/30

Customer	Date 2024-06-13	Company
Contact	Item no.	Issued by
Phone	Project	Phone
E-mail	Project ID Proiect redenumit 2024-06-13 20:42:34	E-mail

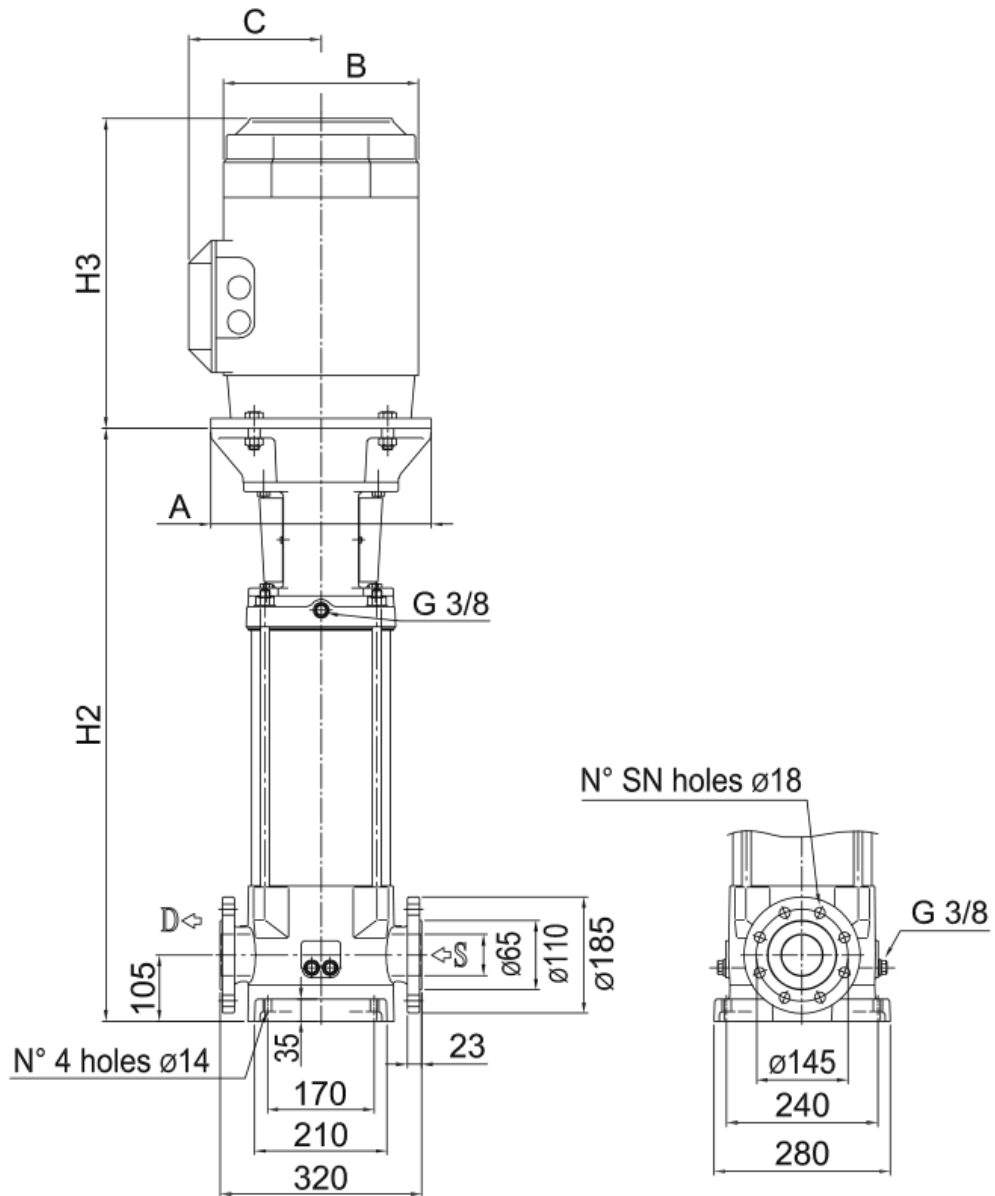

Dimensions in		mm						
1	A	400						
2	B	354						
3	C	280						
4	H2	1246						
5	H3	552						
6	SN	8 (Num)						
7	Weight P&M	361 kg						
8								
9								
10								
11								
12								
13								
14								
15								

(1/4)

Construction

Pump name EVMG32 14-0F5/30

Customer	Date 2024-06-13	Company
Contact	Item no.	Issued by
Phone	Project	Phone
E-mail	Project ID Project redenumit 2024-06-13 20:42:34	E-mail

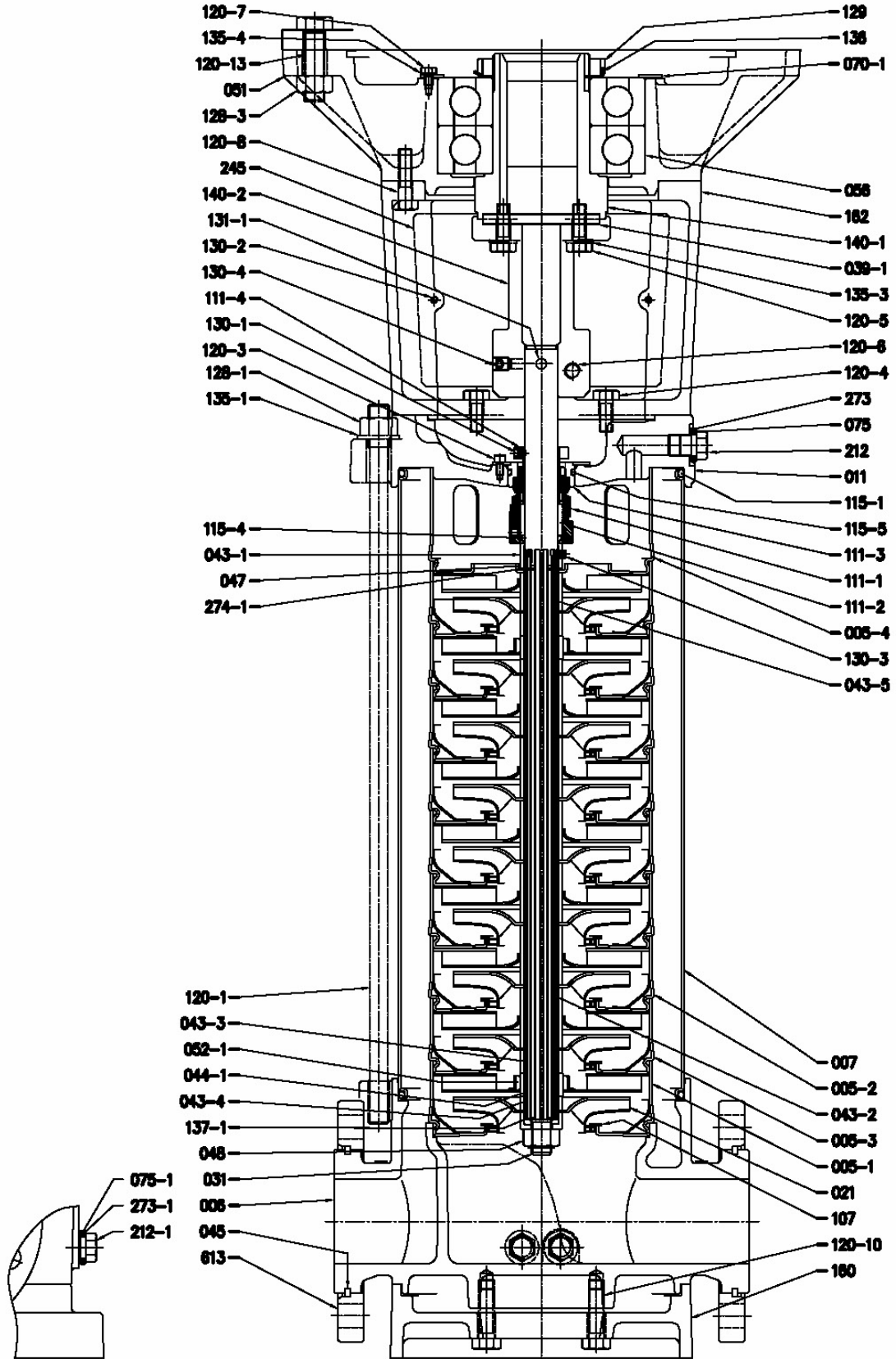

(2/4)

Construction

Pump name EVMG32 14-0F5/30

Customer	Date 2024-06-13	Company
Contact	Item no.	Issued by
Phone	Project	Phone
E-mail	Project ID Proiect redenumit 2024-06-13 20:42:34	E-mail

N°	PART NAME	MATERIAL EVMG	DIMENSIONS	STANDARD	Q.TY
005-1	Suction casing	EN 1.4301 (AISI 304)			1
005-2	Intermediate Casing	EN 1.4301 (AISI 304)			[1]
005-3	Intermediate casing bearing	EN 1.4301 (AISI 304)			[1]
005-4	Discharge casing	EN 1.4301 (AISI 304)			1
006	Bottom casing	Cast Iron EN GJL-250 -EN1561			1
007	Outer casing	EN 1.4301 (AISI 304)			1
011	Casing cover	Cast Iron EN GJL-250 -EN1561			[1]
021	Impeller	EN 1.4301 (AISI 304)			[1]
031	Shaft	EN 1.4401 (AISI 316)			1
039-1	Key	Carbon Steel	12x8x90	UNI 6604	[1]
043-1	Shaft sleeve (mechanical seal)	EN 1.4301 (AISI 304)			1
043-2	Shaft sleeve (intermediate)	EN 1.4301 (AISI 304)			[1]
043-3	Shaft sleeve (bearing)	EN 1.4301 (AISI 304)			[1]
043-4	Shaft sleeve (adjustment)	EN 1.4301 (AISI 304)			[1]
043-5	Shaft sleeve (last stage)	EN 1.4301 (AISI 304)			1
044-1	Shaft sleeve bearing	Tungsten carbide			[1]
045	Flange holder	EN 1.402 (AISI 420)			4
047	Ring Holder	EN 1.4301 (AISI 304)			1
048	Impeller nut	A2-70 UNI 7323 with inox insert	M16		1
051	Motor adapter	Cast iron EN-GJL-200-EN 1561			[1]
052-1	Bearing	Tungsten carbide			[1]
056	Ball bearing				[1]
070-1	Ring for bearing	EN 1.4301 (AISI 304)			[1]
075	O-Ring (plug)	EPDM			1
075-1	O-Ring (plug)	EPDM			4
107	Liner ring	PTFE / EN 1.4301 (AISI 304)			[1]
111-1	Mechanical seal	Silicon carbide / Carbon / FPM			1
111-2	Mechanical seal cartridge	EN 1.4301 (AISI 304)			1
111-3	Mechanical seal seat	EN 1.4301 (AISI 304)			1
111-4	Seal holder	Brass OT 58 UNI 5705			1
115-1	O-Ring (outer casing)	EPDM	D.208.91x5.34		2
115-4	O-Ring (cartridge sleeve)	EPDM	D. 24.99x3.59		1
115-5	O-Ring (seal cover)	EPDM	D.44,04x3,53		1
120-1	Tie-rod	Zincate steel 6.8 strenght class ISO 898/1			4
120-3	Screw	A2-70 UNI 7323	M5x10	UNI 5931	4
120-4	Screw	Zincate steel 8.8 strenght class ISO 898/1	M10x25	UNI 5739	[1]
120-5	Screw for coupling	EVM32 1 EVM32 2 and 2-2 EVM32 5 to 14	M6x16 M8x20 M10x30	UNI 5931 UNI 5931 UNI 5739	[1]
120-6	Screw for coupling	EVM32 1 EVM32 2 to 4-3 EVM32 5 to 14	M6x16 M8x20 M12x30	UNI 5931 UNI 5931 UNI 5931	2
120-7	Screw	Zincate steel 8.8 strenght class ISO 898/1	M6x10	UNI 5739	[1]
120-8	Screw	EVM32 3 to 4 EVM32 5 to 14	M12x25 M10x30	UNI 5739 UNI 5739	[1]
120-10	Screw	Zincate steel 8.8 strenght class ISO 898/1	M12x40	UNI 5739	4
120-13	Screw for motor	EVM32 1 to 2 EVM32 3 to 4 EVM32 5 to 14	M8x20 M12x30 M16x65	UNI 5739 UNI 5739 UNI 5739	4
128-1	Nut for tie rod	Zincate steel	M16	UNI 5588	4
128-3	Nut	Zincate steel	M16	UNI 5588	[1]
129	Lock nut	Carbon Steel			[1]
130-1	Set screw	A2-70 UNI 7323	M6x8	UNI 5923	3
130-2	Screw for coupling guard	A2-70 UNI 7323	M5x6	UNI 7687	4
130-3	Set screw	A2-70 UNI 7323	M6x6	UNI 5923	1
130-4	Set screw	Carbon steel	M10x10	UNI 5923	1
131-1	Pin for shaft	Carbon Steel			1
135-1	Washer	Zincate steel	17x30x3	UNI 6592	4
135-3	Washer	Zincate steel	10.5x17.5x2.2	UNI 1751	[1]
135-4	Washer	Plated carbon steel	06:04	UNI 1751	[1]
136	Washer	Carbon steel			[1]
137-1	Impeller spacer	EN 1.4301 (AISI 304)			1
140-1	Motor coupling	Carbon steel			[1]
140-2	Coupling (motor side)	Carbon steel			[1]
160	Base	Cast iron EN-GJL-200-EN 1561			1
162	Motor bracket	Cast iron EN-GJL-200-EN 1561			1
212	Plug	EN 1.4301 (AISI 304)			1
212-1	Plug	EN 1.4301 (AISI 304)			4
245	Coupling guard	EN 1.4301 (AISI 304)			2
273	Plug Washer	EN 1.4301 (AISI 304)			1
273-1	Plug Washer	EN 1.4301 (AISI 304)			4
274-1	C-type snap ring (mechanical seal)	EN 1.4301 (AISI 304)	D.26	UNI 7435	1
613	Flange	Carbon steel			2

[1] See table on CONSTRUCTION 3

(3/4)

Construction

Pump name EVMG32 14-0F5/30

Customer	Date	2024-06-13	Company
Contact	Item no.		Issued by
Phone	Project		Phone
E-mail	Project ID	Project redenumit 2024-06-13 20:42:34	E-mail

Pump Type EVM()	Quantity for model																														
	005-2	005-3	011	021	021-1	039-1	043-2	043-3	043-4	044-1	051	052-1	056	070-1	107	111-5	120-4	120-5	120-7	120-8	128-3	129	135-3	135-4	136	140	140-1	140-2	150	274-2	274-3
32 13-3F5/30	10	2	1	10	3	1	10	2	2	2	1	2	1	1	13	/	4	4	3	4	4	1	4	3	1	/	1	1	/	/	/
32 13-0F5/30	10	2	1	13	/	1	10	2	2	2	1	2	1	1	13	/	4	4	3	4	4	1	4	3	1	/	1	1	/	/	/
32 14-3F5/30	11	2	1	11	3	1	11	2	2	2	1	2	1	1	14	/	4	4	3	4	4	1	4	3	1	/	1	1	/	/	/
32 14-0F5/30	11	2	1	14	/	1	11	2	2	2	1	2	1	1	14	/	4	4	3	4	4	1	4	3	1	/	1	1	/	/	/

(4/4)

Construction

Pump name EVMG32 14-0F5/30

Customer	Date 2024-06-13	Company
Contact	Item no.	Issued by
Phone	Project	Phone
E-mail	Project ID Proiect redenumit 2024-06-13 20:42:34	E-mail

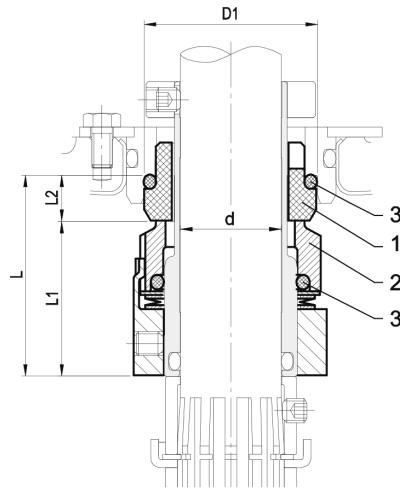

Size [mm]	Max operating pressure [bar]	d [mm]	D1 [mm]	L [mm]	L1 [mm]	L2 [mm]	Material		
							1 Stationary Seal Ring	2 Rotary Seal Ring	3 Rubber
25	30	25	43	50	38.5	11.5	Carbon graphite	Silicon carbide	FPM