

Technical Data

Pump Name

EVMS-K15 1N5Q1BEGE/1.1 TT

Customer	Date	2024-06-14	Company
Contact	Item no.		Issued by
Phone	Project		Phone
E-mail	Project ID	Proiect redenumit 2024-06-14 09:53:20	E-mail

Requested data

1	Pump type	VERTICAL MULTISTAGE PUMP	Fluid	Water
2	Number of pumps / Reserve	1 / 0	Liquid temperature	°C
3	Flow	m³/h	Kin. viscosity	mm²/s
4	Head	m	Vapour pressure	bar
5	Geodetic head	m	PH value	
6	Inlet pressure (pin)	bar	Density	kg/m³
7	Available system NPSH		Solids	Weight %
8	Ambient temperature	°C		

Pump

9	Pump Name	EVMS-K15 1N5Q1BEGE/1.1 TT	Frequency	Hz	50	
10	Design	VERTICAL MULTISTAGE PUMP	Installation type	Oval flange (STANDARD)		
11	Manufacturer	EBARA	Impeller Diameter	Max.	mm	
12	Speed	rpm		2850	Designed	mm
13	No. of Stage	1		Min.	mm	107
14	Connection	Suction side	Flow	Operating	m³/h	
15	Connection	Discharge side		Max-	m³/h	24
16	Max Working Pressure	bar		16	Min-	m³/h
17	Shut-off head	bar	1.41	Head	Operating	m
18	Total weight	kg	See the table of "Dimensions".		- (Qmax.)	m
19	Shaft power	kW			- (Qmin.)	m
20			Max. Shaft Power at max. impeller	kW	0.83	
21	Required pump NPSH	m	Efficiency	%		

Materials

22	Impeller	AISI 304		
23	Intermediate casing	AISI 304		
24	Bottom casing	AISI 304		
25	Shaft	AISI 304		
26	O-ring	EPDM		
27				

Motor

28	Manufacturer	ETM	Insulation class	F	
29	Type	TEFC_EVMS-K15 1/1.1 TT_400_Three Phase	Phases	3~	
30	Specific design	IE3 / 50 Hz / Pole pairs 1	Frame size	80	
31	Rated power	kW	1.1	Weight	kg
32	Number of poles	2	Electric voltage	V	400
33	Speed	rpm	2830	Electric current	A
34	Degree of protection	IP 55			
35					

Remarks

Performance Curve

Pump Name

EVMS-K15 1N5Q1BEGE/1.1 TT

Customer	Date	2024-06-14	Company
Contact	Item no.		Issued by
Phone	Project		Phone
E-mail	Project ID	Proiect redenumit 2024-06-14 09:53:20	E-mail

Requested data

1	Flow	m³/h	
2	Head	m	
3	Geodetic head	m	

Pump

Operating flow	m³/h		Frequency	Hz	50
Operating head	m		Number of poles		2
Impeller diameter designed	mm	107	Speed	rpm	2850

Test standard: ISO 9906:2012 - Grade3B

Water; 20°C; 998.3kg/m³; 1mm²/s

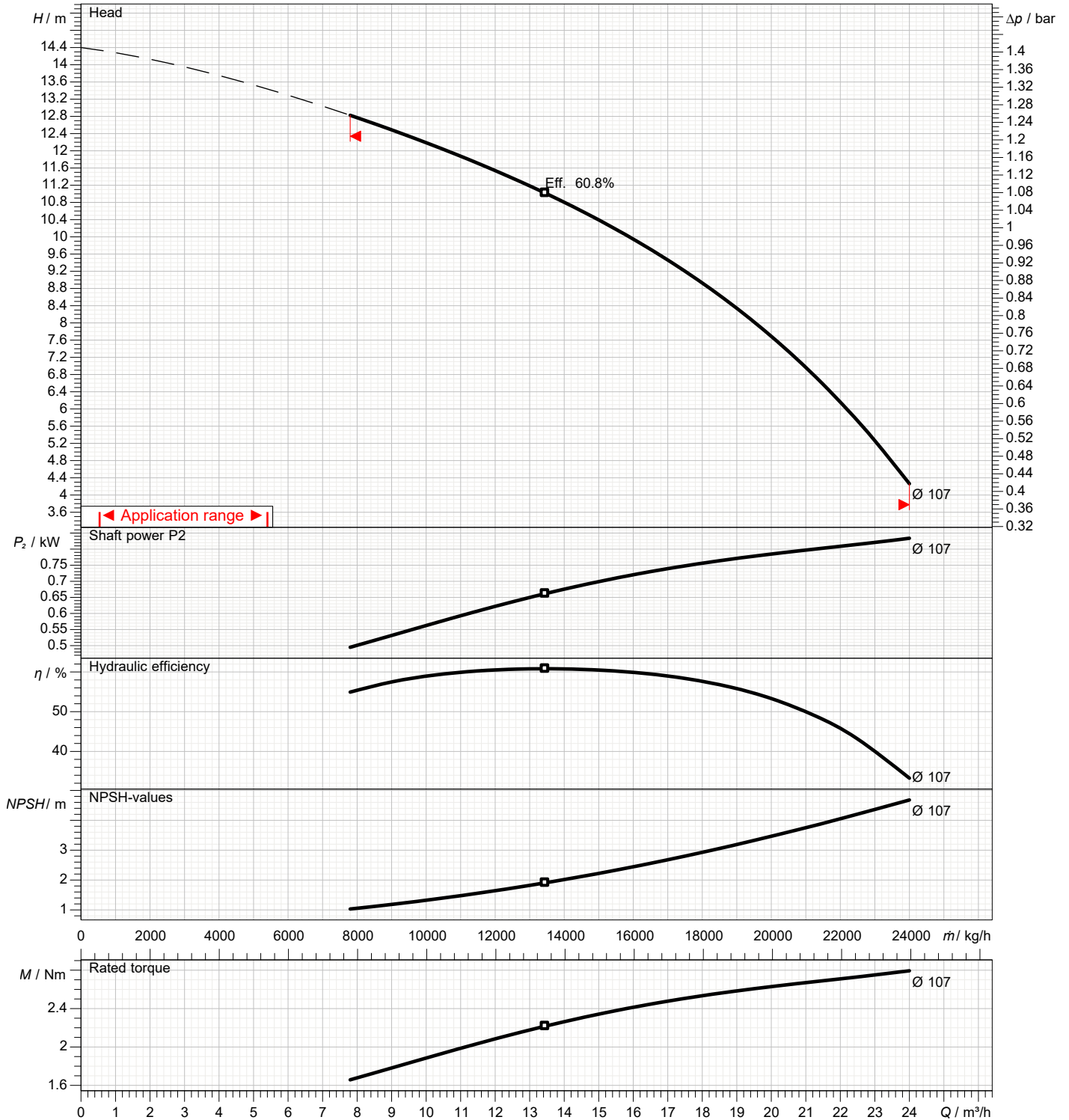

Dimensions

Pump name EVMS-K15 1N5Q1BEGE/1.1 TT

Customer	Date 2024-06-14	Company
Contact	Item no.	Issued by
Phone	Project	Phone
E-mail	Project ID Proiect redenumit 2024-06-14 09:53:20	E-mail

EVMS(L)-K15

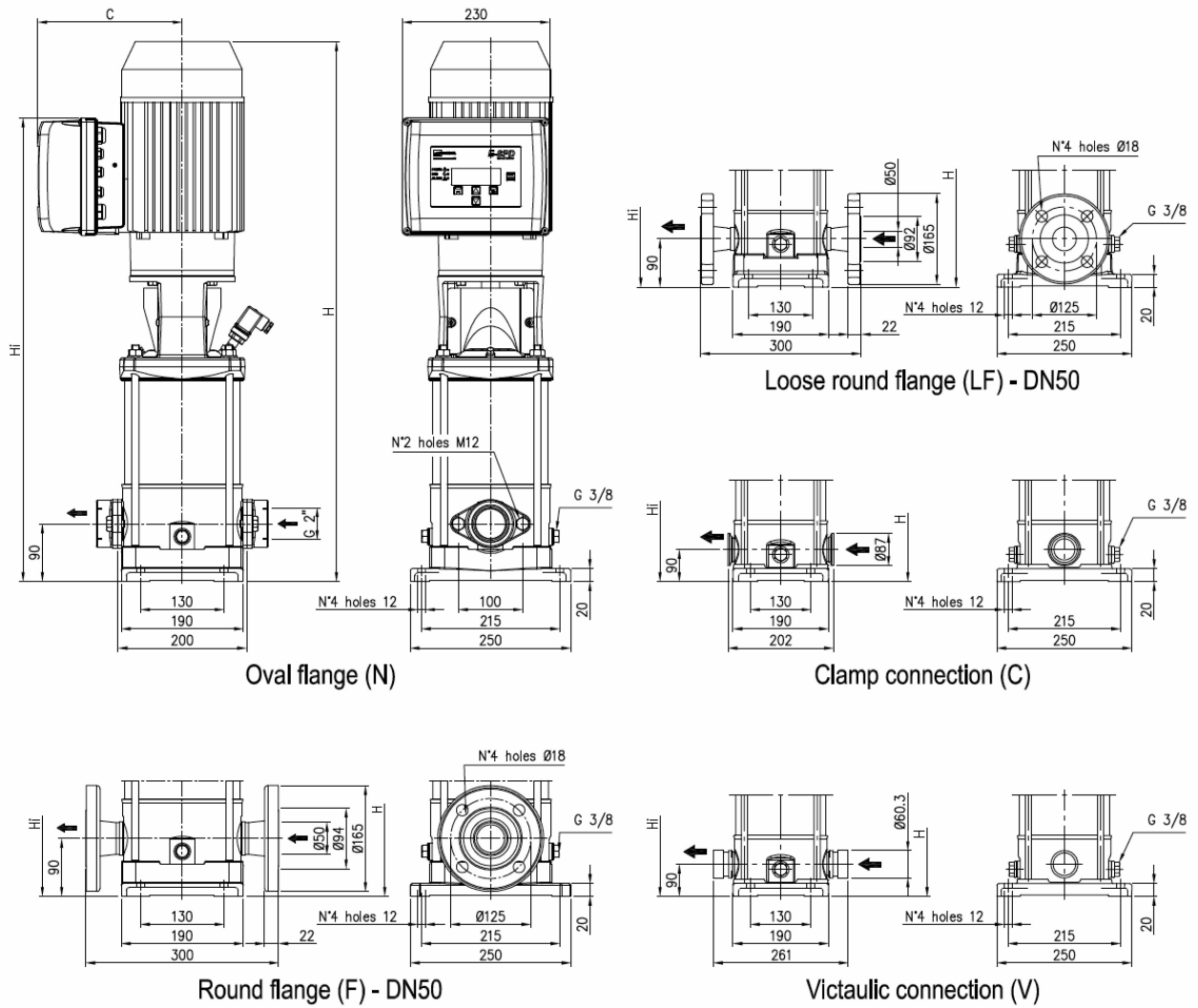

Dimensions in		mm					
1	C	191					
2	H	621					
3	Hi	605					
4							
5							
6							
7							
8							
9							
10							
11							
12							
13							
14							
15							

(1/2) Construction

Pump name EVMS-K15 1N5Q1BEGE/1.1 TT

Customer	Date 2024-06-14	Company
Contact	Item no.	Issued by
Phone	Project	Phone
E-mail	Project ID Proiect redenumit 2024-06-14 09:53:20	E-mail

EVMS-K

EVMSL-K

EVMSG-K



POS	PART NAME	MATERIAL	QUANTITY
1	EVMSG-K PUMP	EN-GJL-250 (CAST IRON)	1
	EVMS-K PUMP	EN 1.4301 (AISI 304)	1
	EVMSL-K PUMP	EN 1.4404 (AISI 316L)	1
2	ELETRIC MOTOR	ALUMINIUM	1
3	INVERTER	ALUMINIUM-PLASTIC	1
4	PRESSURE TRANSDUCER	EN 1.4301 (AISI 304)	1

(2/2)

Construction

Pump name EVMS-K15 1N5Q1BEGE/1.1 TT

Customer	Date 2024-06-14	Company
Contact	Item no.	Issued by
Phone	Project	Phone
E-mail	Project ID Proiect redenumit 2024-06-14 09:53:20	E-mail

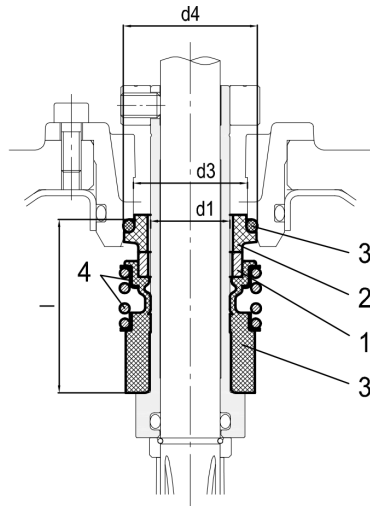

● : Standard

Pump model	Max operating temperature	Shaft seal type		Shaft seal material								Type key	
		Cartridge		1		2		3		4			5
Max operating pressure		Unbalanced	Balanced	Rotating Part	Code	Stationary Part	Code	Elastomers	Code	Compression spring	Collar	Code	
up to 16 bar	- 30°C to + 120°C	●		SiC	(Q1)	Carbon	(B)	EPDM	(E)	AISI 316		(G)	Q1BEG

Max operating pressure	d1	d2	d3	d4	l
	[mm]	[mm]	[mm]	[mm]	[mm]
16 bar	20	-	29	35	37.5